



Cabinet Systems Manual | Summer 2025

Conestoga Wood Specialties Corporation
 245 Reading Road, P.O. Box 158
 East Earl, Pennsylvania 17519-0158
 717-445-6701

Key Contact Information			
Department	Phone	Fax	Email
Customer Service	(800) 838-5850	(800) 611-0730	customerservice@conestogawood.com
Special Designs	(800) 844-5932		specialdesigns@conestogawood.com
Credit	(800) 863-9561	(800) 328-6474	credit@conestogawood.com
Customer Service General Number	(800) 964-3667		

© 2025 Conestoga Wood Specialties Corporation. All the information contained herein is thought to be accurate at the time of printing. However, no responsibility is assumed by Conestoga Wood Specialties Corporation. All rights reserved. Reproduction of any part of this publication without the express written permission of Conestoga Wood Specialties Corporation is a violation of applicable laws. Order forms may be reproduced without notice to Conestoga Wood Specialties Corporation provided they are used to order Conestoga Wood Specialties Corporation products. All prices and specifications are subject to change without notice. All pictures and graphics are for visual representation only. This publication supersedes all prior technical, policy and price data.

About Conestoga Wood Specialties

Since 1964 Conestoga Wood Specialties has manufactured the highest-quality cabinet doors and components for the Kitchen & Bath Industry. From our modest beginnings in a small garage in Lancaster County, Pennsylvania, we've grown to the industry leader known for our consistent quality, breadth of selection, on-time deliveries, and product performance.

While our roots run deep in producing finely crafted wood components, we've never stopped looking for "what's next", relentlessly searching for new designs, materials, accessories, and services to assist our customers in keeping abreast of developing design trends. While predominantly known for our work with wood, Conestoga has repeatedly stepped outside our historic comfort zone to capitalize on developments in technologies and materials. We frequently travel to Europe to develop and strengthen supplier relationships while exploring revolutionary new materials. We work with some of the world's leaders in alternative material sheet stock and make substantial investments in inventories to help bring these products to our customers here in the U.S. ... and our search continues.

Conestoga's commitment is to provide our customers with superior products and to monitor the market making every attempt to understand where it is headed, then doing our best to provide the products and styles needed to allow our customers to capitalize. Several years ago, we anticipated the rise of painted finishes and aggressively promoted hybrid products, then introduced 5-Piece MDF doors well before they became widely accepted by the industry. We launched the Prism Paints Program, bringing over 1,400 paint colors to our standard finish offerings. Today, these programs continue to thrive and remain a cornerstone of our Custom product offering.

For over 40 years Conestoga has produced domestically manufactured Ready to Assemble Framed cabinetry, allowing our customers to supplement their standard offerings. Recently, Conestoga expanded our RTA cabinet program to include a Full Access cabinet line in both Plywood and Alternative Materials. This latest effort allows U.S. cabinet shops to directly compete with imported cabinetry, providing numerous options and size customization with a myriad of door styles, drawer fronts, accessories and finishes to suit nearly every preference.

And while we've experienced countless changes, our company has stayed true to its roots, continuing to produce thousands of wood doors, drawer boxes, front frames, mouldings, and other components every day. Conestoga remains a family-owned business, committed to servicing the Custom, OEM, and RTA Cabinet Systems Kitchen & Bath segments. We've entered our sixth decade in business, and remain dedicated to the principles that elevated Conestoga to the top of the kitchen component industry while understanding that we must be receptive to new ideas and agile enough to successfully institute them to stay relevant, and allow our customers to ascend to the forefront of the custom kitchen market.

But most of all, we have never forgotten that relationships are built one delivery at a time.

www.conestogawood.com

1 Overview

Program Overview (Variety, Design Flexibility, Customization, Savings)	1.1-1.2
Credit Terms	1.3
State and Local Tax	1.3
Custom Product Quote Request	1.3
Order Placement	1.3
Order Forms	1.4
Customer Purchase Orders	1.4
Order Acknowledgements	1.4
Order Changes/Cancellations	1.4
Shipping Options and Methods	1.5
Drawer Box and Cabinet Systems Orders	1.6
Standard Box Packaging	1.6
Skid Pack Packaging	1.6
Handling & Packaging Upcharges	1.6
Freight Terms	1.7
Customer Pick Up	1.7
Customer Receiving Process	1.7
Damaged and Defective Product Policies	1.7
Return Merchandise Authorization (RMA)	1.7
Freight Damage Claims	1.8
Missing Product Claims	1.8
Replacement Order Process	1.8
Product Warranty Information	1.9
Finishing Warranty Information	1.10
Marketing Support Materials (Product Manuals, Interactive Tools, Point of Purchase Items)	1.11-1.12

2 Offerings

Lead-Time Information	2.1
Order Timing	2.1
Expedite Programs	2.2
Replacement Lead-Time	2.2
Door and Drawer Front Specifications	2.3
Specie and Grade Characteristics	2.4-2.5

3 Finishing Program

Finishing Program Overview	3.1
Finishing Process.....	3.1
Finishing Tolerances	3.1
Finishing Warranties.....	3.2
Wiping Stains.....	3.2
Custom Stain Matching.....	3.2-3.3
Truetones	3.3
Wiping Stains and Truetone with Hand Wiped Glazes.....	3.3-3.4
Primed Products	3.4-3.5
Colourtones	3.5-3.6
Prism Paints.....	3.6-3.7
Colourtones and Prism Paints with Glazes.....	3.7-3.8
Customer Responsibilities	3.8
Prism Paint Fan Deck.....	3.9
Advantage Finishing Options	3.10
Vesta Finishing Options	3.11
Offering and Availability	3.12-3.15
Cabinet Systems Finishing Pricing.....	3.16-3.17
Finish Sample Kits	3.18
DuraGuard System Overview, Features and Disclaimers.....	3.19
DuraGuard Pricing	3.20
DuraGuard Finishing Instructions.....	3.21-3.26
DuraGuard Legal Disclaimers	3.26
Health and Safety Information.....	3.26
Care and Cleaning of Fine Kitchen Cabinetry	3.26
Customer Supplied Parts for Finishing	3.27
Customer Wiping Stain Match Form	3.28

4 Material Pricing Guide

Material Pricing Guide

5 Advantage Specifications

Exploded Advantage Framed Cabinet Drawing	5.1
Advantage Design and Assembly	5.2
All Plywood Construction	5.2
Advantage Component Specie Availability.....	5.3
Door Overlays	5.3
Overlay Diagrams w/ Center Stile	5.4
Advantage Inset Door and Drawer Information.....	5.5-5.6
Inset Door Diagram w/ Center Stile	5.6

6 Advantage Wall Cabinets

Wall Cabinet Standard Features and Options	6.1
Wall Standard Cabinets – 12-1/2" deep (W, CSWOU, CSWCS, CSW2CS)	6.2-6.3
Wall Blind Corner Cabinets (WBC, CSWBCCS)	6.4
Wall Corner Cabinets (WCS, WCSLS, WCP, WCPLS)	6.5-6.7
Wall Specialty Cabinets (WAE, WOS, WOSST, CSWS3D, CSWS4D, CSWS5D, CSWRC3, W1D, W2D, WOBS, CSWOBSCS, CSWMB, CSWMWS, TTW, TTWCSE, TTWCP, CSRH, WDE, WXC, W1X, WHKXS, CSWHL, CSWHK, CSWAC, CSWAHL, CSWCO)	6.8-6.20

7 Advantage Base Cabinets

Base Cabinet Standard Features and Options	7.1
Base Standard Cabinets (B, CSB2D1D, CSBBD2D, CSB2D2D, CSB3D3D, BTCP, BPO)	7.2-7.3
Base Sink Cabinets (BS, CSBS2D1D, CSBS2D2D, ASB, CSASBCS, BSFD)	7.4-7.5
Base Full Door Cabinets (BFD, CSBFDCS, CSBFD2CS, BFDRO, BFDROI, BFDPO, BFDTD)	7.6-7.8
Base Drawer Cabinets (CSB1D, CSB1DCS, CSB1D2CS, B2D, B2DRO, B3D, B3DEH, B4D, B4D2S2EH)	7.8-7.10
Base Corner Cabinets (BCFD, BCFDLS, BSC, BCP, BCPLS, BCP3D, BBCR(L), BFDBCR(L))	7.11-7.15
Base Specialty Cabinets (BCT, CSBCT2D, BR3D, CSBCT4D, BRT2D, CSBRT4D, BUCM, BIUCM, BAE, BEAR(L), CSBDE, CSBDE2D1D, BDE, CSBC3DL(R), CSBC3DLCS, CSBC3DR, CSBC3DRCS, CSBC4DCS, CSB2D5D, CSBOU, CSBPU, CSBCO)....	7.16-7.22

8 Advantage Tall Cabinets

Tall Cabinet Standard Features and Options	8.1
Utility Cabinets (UCD, CSUCCS, UCDW, CSUCWS, UCDR, CSUCRCS, UCDRRO, UCDRROI, U2D, U3D)	8.2-8.6
Oven Cabinets (ODA, ODB, CSOS)	8.7-8.8
Refrigerator Cabinets (CSRTB, CSRTBCS, CSRTBHKXS, CSRTL, CSRTLCS, RTLHKXS, RTR, CSRTRCS, RTRHKXS)	8.8-8.11
Tall Corner Hutches (TCH)	8.12
Case Only Cabinets (CSCO, CSCONH)	8.13

9 Advantage Vanity Cabintes

Vanity Cabinet Standard Features and Options	9.1
Vanity Standard Base Cabinets (VB)	9.2
Vanity Sink Base Cabinets (VS, CSBS2D1D, VSX, VBS, CSVBSCS, VSRV, CSVSRVCS)	9.2-9.4
Vanity Full Door Base (VBF)	9.4
Vanity Drawer Base Cabinets (V3D, V4D, VCL, VCR, VC3DL(R), VCFD3DL(R), VC6D, VC3D)	9.5-9.8
Vanity Wall Hung Cabinets (WHV, CSWHVCS, WHV2D)	9.9
Vanity Linen Utility Cabinets (CSVLV, CSUCR, CSUC, CSVL3V, CSU3D)	9.10-9.12
Vanity Wall Cabinets (VW, VWS)	9.13

10 Advantage Home Office/Media Cabinets

Home Office/Media Cabinets Standard Features and Options	10.1-10.2
Home Office Base Cabinets (DB, DBFD, DB2D, LF2D, DB3D, DD, DDSL(R)).....	10.3-10.4
Letter File Slot (CSLFS)	10.5-10.6
Home Office/Media Tall Cabinets (ORC, ORS)	10.6
Home Office/Media Wall Cabinets (W1D, CSW1DCS, W2D, CSW2DCS, WOBS, WOBSCS).....	10.7-10.8
Media Center Cabinets (MC2FD, MC3FD, MC2D, MC3D, MC2D2D, MC2D3D).	10.9-10.10

11 Advantage Accessories

Dishwasher/Refrigerator End Panel (DWEF, REP)	11.1
Filler Strips (CSFSW, CSFSB)	11.1
Wall, Base & Tall Filler Columns (WFC, BFC, TFC)	11.2
Zero Angle Filler (ZAFL(R)).....	11.2
Wine Storage Units (WSU, WSUD)	11.3
Trash Can Pull-Outs (TCPTS, TCPTD, TCPTN).....	11.4
Pull-Out Trays (CSPOTB, CSPOTBFD, CSPOTU, CSPOT1, CSPOT1CS, CSPOT2, CSPOT2CS, CSPOTT, CSPOTS, CSPOTSCS)	11.5-11.7
Roll Out Shelf (CSROS, CSROSI)	11.8
Loose Fixed Floor Kit (CSFFK)	11.8
Lazy Susan Shelves.....	11.9
Finished Bottom Panels for Wall Cabinets.....	11.10
Loose Toe Platform (CSLTP)	11.10
End Skins - Program Species	11.11

12 Advantage Options

Exposed Ends (EXP)	12.1
Flush Ends (FL).....	12.1
Flush Unexposed Ends (FUE).....	12.1
Prep for False Door Side Option (PFD)	12.2
False Door Side (FDS)	12.2
Extended Side Back (ESB)	12.2
Extended Height Options – Tall Cabinets	12.3
Toe Space Side Option (TSS)	12.3
Plywood Toeboard Strips	12.4
Plywood Toeboard Backer (PTB)	12.4
Square Toe Kick Notch Option (STN).....	12.4
Extended Stiles (EXT, CSEXT)	12.5
Flush Toe (FT).....	12.5
Leg Extension (LE).....	12.5
Shaped Bottom Rail (SBR)	12.6

Shaped Side (SS)	12.6
Omit Shelving (OS)	12.7
No Shelf Hole Option (NSH)	12.7
Extra Deep Shelf (EDS)	12.7
Solid Wood Shelf Upgrade (WS)	12.7
Matching Interior (MI)	12.7
Dust Top (DT)	12.8
Natural Finished Bottom (NB)	12.8
Custom Top/Bottom Reveal (CTR, CBR).....	12.9
Increase Side Reveal (ISR)	12.9
Cabinet Hinge Options.....	12.10-12.12
Drawer Slide Options	12.12

13 Vesta Specifications

Exploded Vesta Full Access Cabinet Drawing	13.1
Vesta Design and Assembly	13.2-13.3
Vesta Material Availability.....	13.4
Vesta Construction Methods	13.5
Door Overlay Diagram.....	13.5

14 Vesta Wall Cabinets

Wall Cabinet Standard Features and Options	14.1
Wall Standard Cabinets – 13" deep (W)	14.2
Wall Corner Cabinets (WBC, WCS, WCSLS, WCP, WCPLS)	14.3-14.5
Wall Specialty Cabinets (W1D, W2D, WOBS, WOBSCS, WMB, WMWS, TTW, TTWCSE, TTWCP, WHKXS, CSWHL, CSWHK, CSWAC, CSWACHL).....	14.6-14.11

15 Vesta Base Cabinets

Base Cabinet Standard Features and Options	15.1
Base Standard Cabinets (B, BTCP)	15.2
Base Sink Cabinets (BS, ASB, BSFD)	15.3
Base Full Door Cabinets (BFD, BFDRO, BOU).....	15.4-15.5
Base Drawer Cabinets (CSB1D, B2D, B2DRO, B3D, B3DEH, B4D)	15.6-15.7
Base Corner Cabinets (BCP, BCPLS, BCFD, BCFDLS, BBCR(L), BFDBCR(L))	15.8-15.11
Base Specialty Cabinets (CSBCT2D, BR3D, BRT2D, BUCM, BIUCM, CSBCO)	15.12-15.13

16 Vesta Tall Cabinets

Tall Cabinet Standard Features and Options.....	16.1
Utility Cabinets (UCD, UCDW, UCDR, U2D, U3D, U3DEH).....	16.2-16.5
Oven Cabinets (ODA, ODB, CSOS).....	16.6-16.7
Refrigerator Cabinets (CSRTEPC, CSRTB, CSRTBHKXS)	16.7-16.8
Case Only – Customizable (CSCO)	16.9

17 Vesta Vanity Cabinets

Vanity Cabinet Standard Features and Options	17.1
Vanity Standard Base Cabinets (VB)	17.2
Vanity Sink Base Cabinets (VS, VSRV)	17.2
Vanity Full Door Base (VBF).....	17.3
Vanity Drawer Base Cabinets (V3D, V4D, VCL, VCR, VC3DL(R), VC3DR, VC3D, VC6D).....	17.3-17.6
Vanity Wall Hung Cabinets (WHV, WHV2D)	17.7
Vanity Tall Linen Cabinets (CSUCR, CSU3D)	17.8

18 Vesta Home Office/Media Cabinets

Home Office/Media Standard Features and Options	18.1
Home Office/Media Base Cabinets (DB, DBFD, DB2D, LF2D, DB3D, DD)	18.2-18.3
Home Office/Media Wall Cabinets (W1D, W2D, WOBS, WOBSCS)	18.4-18.5

19 Vesta Accessories

End Panels (WEP, BEP, TEP)	19.1
Trim Panel (TP)	19.2
Filler Strips (CSFSW, CSFSB)	19.2
TTS Mouldings (Narrow Overlay, L-Moulding, Scribe)	19.3
Lazy Susan Shelves.....	19.4
Loose Fixed Floor Kit (CSFFK)	19.4
Loose Toe Platform (CSLTP)	19.4
Roll Out Shelf (ROS, CSPOTB, CSPOTBFD, CSPOTU)	19.5-19.6

20 Vesta Options

Standard Options (OS, NSH, NHH, NDSH, MCC)	20.1
Exposed Ends (EXP)	20.2
Dust Top (DT)	20.2
Custom Top and Bottom Reveals (CTR, CBR)	20.2
Increased Side Reveal (ISR)	20.3
Toeboard Strips/Plywood Toeboard Strips	20.4
Square Top Notch Option (STN)	20.4
Flush Toe (FT)	20.4
Drawer Slide Options	20.5
Cabinet Hinge Options.....	20.5
Blum Full Access Cabinetry Hinge Program.....	20.6-20.9

Conestoga Cabinet Systems

Conestoga's Advantage Framed and Vesta Full Access Cabinet (FAC) Systems Programs significantly reduces the amount of labor needed to construct custom kitchens. Combining quality, variety, flexibility and cost savings, the more than 1,500 SKUs greatly reduces the need to hire labor in both the shop and finishing areas of your operations.

The ready-to-assemble cabinet box offers solid wood dovetail drawer boxes, soft close drawer slides and hinges along with a number of optional enhancements. These options allow customization of each kitchen to meet the specific needs. Choose from more than 100 Conestoga door and drawer front designs in traditional and full overlays as well as an inset option. To further reduce labor needs, our Cabinet Systems can be ordered in thousands of standard paint, stain and glaze combinations to provide the perfect finishing touch. The Vesta program also offers all Alternative Material door programs.

Variety

With over a hundred standard configurations and almost limitless sizing options, the Cabinet Systems Program provides everything you need to design and build a broad variety of cabinetry for kitchens, baths and other room applications. From Walls, Bases, Utilities, Appliance, Vanity and Specialty cabinetry, this expansive collection, combined with over 100 door design options, allows cabinet manufacturers to meet nearly every design need.

Design Flexibility

While strong, stable construction is critical, another important feature is the appearance of the face of the cabinetry. Whether designing and building a kitchen that is modern, transitional or traditional, Conestoga's vast door and drawer front offering allows you to alter the look and feel of each and every project. In Advantage choose from 1/4", 1/2", 1-1/4" and 1-3/8" overlays, or the popular inset option. Vesta FAC features the traditional full overlay look with 1/8" spacing between components.

- **Custom Doors** – Choose from the over 100 wood or MDF door and drawer front designs found in Conestoga's Custom Product Manual. Most designs offer a variety of framing beads, panel raises, edge profiles and custom width framing options, allowing customers to create an almost limitless variety of custom designs. Custom product pricing and lead-times apply.
- **Alternative Material Doors** – Conestoga's six Alternative Material programs can be combined with our Vesta FAC White Birch, Coastal White or Fog Grey standard cabinet colors. Choose from over 70 colors, patterns and textures within the Allure DLV, Intrigue TTS, Strata TTS, Vogue TTS, Synchronicity High Gloss or Synchronicity Super Matte Collections. Matching cases and doors are available in Coastal White or Fog Grey Slab design, or in all Intrigue TTS Strata TTS, and Vogue TTS colors.
- **Door Matching Edgeband** – The Vesta offering provides an optional Door Matching Edgeband feature which allows the front edges of the side panels, tops and bottoms to be banded with edgeband to match the doors and drawer fronts. This option is available on both plywood and Alternative Material cabinets and includes all colors within the Allure DLV, Intrigue TTS, Strata TTS, Vogue TTS, Synchronicity High Gloss and Synchronicity Super Matte programs. Vesta Plywood cabinetry is also available with matching specie Door Matching Edgeband.
- **Custom Drawer Boxes** – 5/8" solid wood dovetail drawer boxes are included with all configured door style cabinets. Most drawer box options and accessories are available. See Section 10 of the Custom Product Manual.
- **Functional Hardware** – Each Advantage RTA cabinet includes Blum COMPACT hinges and TANDEM drawer glides, both with integrated soft close. Vesta RTA cabinetry includes Blum INSERTA hinges and TANDEM drawer slides with integrated soft close. Please note that some INSERTA special hinges do not include the soft close feature. Customers have the option to decline any of the functional hardware if they wish to supply their own.
- **Custom Mouldings** – A variety of solid wood crown, baseboard and trim mouldings are available. See Section 9 in the Custom Product Manual.
- **Interior Storage Options** – Over 50 popular interior storage items are located in Section 10 of the Custom Product Manual. Choose from various trash can pull-out units as well as a wide variety of Base, Wall, Utility and Vanity pull-out units, and more. These Interior Storage items are sized to fit within both the Advantage and Vesta cabinet lines.

Customization

- **Custom Sizing** – In addition to the broad selection of standard cabinet configurations, Conestoga offers size customization for nearly every cabinet design. Custom sizing can accommodate width, height and even depth requirements in most cases. Cabinets with drawers are limited to drawer slide hardware lengths.
- **Custom Finishing** – Our finished component program allows customers to order individual cabinet parts finished to match doors and drawer fronts. Simply assemble the prefinished component parts and you're ready to install.
- Conestoga Cabinet Systems also offers options to enhance customers' product offering, such as optional matching interiors, extended stiles, exposed ends, flush ends, flush toe, shaped bottom rails, wood shelf upgrade, inset or overlay door styles and more.

Time and Cost Savings

- **Complete Cabinet Systems Units** – Each cabinet unit comes with all necessary pre-machined parts, Blum hinges and drawer slides, shelf supports and doors needed to build a complete cabinet. Most parts are packaged together per unit and ready to assemble.
- **Ease of Assembly** – Dovetail construction and pre-inserted assembly splines make assembly fast and easy. Due to this combination of joinery, assembly clamps are not needed. Complete Assembly Instructions featuring all Cabinet Systems configurations are available by simply checking the Assembly Instructions box on Order Forms 7, 7-A and 8 or by selecting "yes" to Assembly Instructions on Con-Nex.
- **Streamline Manufacturing** – Complete ready-to-assemble units minimize the time required to order, schedule, receive and handle materials. With prefinished cabinet interiors, shelves and drawer boxes, time is saved, bottlenecks reduced and VOC emissions lowered within your shop.
- **Prefinished Components** – Components come standard with a durable UV topcoat on the interior of plywood end panels, tops, bottoms, shelving and backs. Conestoga also offers our premier stains, glazes and paints on cabinet exteriors including front frames, doors, drawer fronts, end panels and toe kick strips. When the Matching Interior Option is selected, the interior components arrive unfinished or finished to order.
- **Lower Costs** – The pre-machined, prefinished cabinet components greatly reduces the time needed to manufacture complete kitchens. This simplified system allows utilization of lower cost labor for cabinet assembly, minimizing your labor cost per box and freeing highly skilled labor to focus on more difficult projects.
- **Reduce Overhead Costs** – Overhead costs of shop equipment and floor space are reduced or eliminated by using the Cabinet Systems Program rather than building from scratch.
- **Improve Yields** – The cost of material and material yields are consistent when using the Cabinet Systems Program. Waste is practically eliminated.
- **Improved Cash Flow** – The Cabinet Systems Program can help improve cash flow with faster throughput, lower cost per unit and minimal or no inventory. Add sales revenue and capacity without large capital investments.

Credit Terms

- Conestoga has two standard types of credit terms: 100% prepay and open credit, subject to financial creditworthiness. 100% prepay accounts require full payment for orders before work begins. Open credit term accounts (2% 10, net 30) are subject to the terms and conditions stated on Conestoga's Credit Application and will be reviewed periodically. Past-due balances are subject to a late fee of 1.5% monthly or 18% annually.
- All new customer accounts are initially set up as 100% prepay until Conestoga has approved your Credit Application. For a Credit Application, contact your Sales Representative or our Credit Department. Open credit term customers are subject to periodic review and credit limits are adjusted accordingly.
- Methods of payment include: Payment through our Customer Business Portal, Mail, or by Phone.
- Payment types accepted: check, credit card (American Express, Discover, MasterCard, and Visa), wire, and Automated Clearing House (ACH).

State and Local Sales Tax

- To qualify for state and local sales tax exemptions, Conestoga requires a valid state sales tax exemption certificate. Without a certificate on file, we are obligated to apply applicable state and local taxes to all purchases. Note that a state sales tax license or seller's permit is not sufficient to exempt purchases.
- For purchases shipped to other states, applicable sales tax may be charged based on the destination state, as laws vary.
- If taxes are applied and a tax exemption certificate is submitted at a later date, Conestoga can only issue credit for taxes charged within 60 days prior to receiving the certificate.
- For questions about sales tax exemption, please contact our Credit Department at 1-800-863-9561 or credit@conestogawood.com.

Custom Product Quote Requests

- Immediate product quotations can be generated via Con-Nex®; contact Customer Service for details, 1-800-838-5850 option 2.
- All product quotation requests must be submitted in writing. Always clearly write or type "QUOTE" in the header of the form or select the QUOTE box at the top of the form.
- Quotes will be processed within a timely manner of receipt and will be acknowledged by your preferred communication method.
- Log in to the Customer Business Portal (CBP), my.conestogawood.com, to convert your quote to a live order or sign the last page of your acknowledgement and return it to Conestoga.

Order Placement

- Contact Customer Service if assistance is required with Quotes and/or Orders.
- Conestoga offers four methods of order placement: Conestoga Con-Nex®, email, fax and mail. Fax, phone and email information to contact Customer Service is listed on the first page of this manual.
- Our Con-Nex quoting and ordering program is a 24/7 order processing software package that provides an easy way to obtain instant quotes and electronically place orders. For more information on Con-Nex contact our Help Desk: 1-800-838-5850, option 2.
- Inbound fax lines are available 24 hours a day, seven days a week.
- Phone lines are open during office hours – 8:00 a.m. to 5:00 p.m. (EST), Monday through Friday.
- When sending orders via U.S. Mail, use the address below. The address **must** include "Attention: Customer Service", followed by the word "ORDER".

Conestoga Wood Specialties Corporation
ATTN: Customer Service – **ORDER**
245 Reading Road, PO Box 158
East Earl, PA 17519-0158

Order Forms

- All orders must be submitted written or typed on a Conestoga Order Form or a pre-approved customer Purchase Order Form. Verbal orders will not be accepted.
- Complete all header information. If you use your company-specific order forms, include all required fields. Customer Service is available to assist you in developing your forms.
- When adding, correcting, or otherwise modifying information on an order that has previously been submitted, all changes must be submitted in writing.
- All orders must be submitted in finished dimensions.
- Master copies of each Order Form can be downloaded from the Customer Business Portal or Section 14 of the Custom Product Manual. Refer to the back page of Conestoga Order Forms for ordering instructions. If you have questions regarding Order Forms or the product catalog, contact Customer Service.
- Use Conestoga terminology when placing orders.
- Incomplete Order Forms will delay order processing.

Customer Purchase Orders

- Our system allows the same purchase order number or name to be used multiple times. To avoid duplicate orders, please assign a unique purchase order number or name to each order submitted.
- Customers are responsible for any duplicate orders submitted.
- If you are uncertain whether your order has been received, verify it through the CBP or by contacting Customer Service.

Order Acknowledgements

- Conestoga provides order acknowledgements via email, fax, or viewed on the CBP.
- Order status can be checked on the CBP.
- Acknowledgements confirm that the order entered in our system matches your provided details. Please review promptly for accuracy.
- If you identify any errors, contact Customer Service immediately.
- To update your preferred method for receiving acknowledgments, log onto the CBP and adjust your preferences in the "My Account" section.

Order Changes/Cancellations

- Change and cancellation requests can be submitted through the CBP or in writing. Use the Conestoga acknowledgement for written requests and mark "Change Order" at the top. Include the original purchase order and specify the item(s) to be modified or canceled.
- Orders that have been entered into our computer system but not released into production can be modified or canceled with no upcharge.
- **Order change fees will be applied to the original purchase order for any modifications to orders that have been released into production.** Order change fees vary and are determined by the manufacturing completion percentage.
- Change or cancellation requests may be denied altogether if the product has progressed beyond a critical manufacturing point and order lead-times may be affected.
- Some products or order types cannot be modified or cancelled.
- Cabinet orders are complex and any changes such as finish color, cabinet material, or door design should be made by resubmitting the order through Con-Nex®.

Shipping Options and Methods

- Conestoga offers a variety of shipping methods, including our company-owned fleet of trucks, common carriers, and UPS Ground or FedEx Ground.
- Conestoga Wood Transportation operates several daily and weekly route trucks to many parts of the Northeast, Southeast, and Midwest. Our route trucks are designed to deliver customer orders economically, reliably, and damage-free. If you're interested in utilizing Conestoga's transportation service, please contact your Conestoga Sales Representative for more details.
- Conestoga trucks are available on a limited basis. Several guidelines and restrictions apply (see below).

Restrictions include:

- **Delivery Routes** - Conestoga has several established delivery routes to service areas that support high-volume freight deliveries. Areas outside these established delivery networks may not contain the necessary volume needed for cost-effective delivery service. Customer locations outside established delivery routes will be serviced by select common carriers.
- **Purchase Quantities** – We strive to prioritize high-volume customers for delivery using Conestoga equipment. Customers located near larger, frequently ordering clients may qualify for Conestoga truck deliveries. However, customers with infrequent orders or those outside established delivery routes will be served by selected common carriers.
- **Delivery Frequency** – Conestoga route trucks generally travel once per week to regions outside our local delivery areas unless the overall territory volume justifies multiple deliveries. Conestoga truck deliveries can be supplemented by common carrier if desired, however, common carrier deliveries will likely cost more than Conestoga deliveries.
- **Receiving Deliveries** – Conestoga uses straight trucks with lift gates or tractor trailers, depending on the service area. For deliveries made with tractor trailers, customer facilities must have a loading dock and the necessary equipment to handle pallets.
- **Residential/City Deliveries** – Some customers in residential and city locations may have insufficient space for tractor trailers to safely maneuver even if volume and location warrant, therefore Conestoga trucks will not offer delivery.
- **Common carriers** are used to ship orders outside our delivery routes, to lower-volume customers, or to regions more difficult to access. Conestoga has negotiated discounted rates with several carriers and will choose the most economical and timely carrier for your area.
- **Customers' facilities** must be able to accommodate LTL shipments. A truck dock and skid-handling equipment are required to receive these shipments.
- **FedEx Ground and UPS Ground** are the primary shipping methods used to ship smaller orders and groups of orders totaling less than five packages.
- **Expedited services** are available via FedEx Ground and UPS Ground for products whose weight and size qualify. Any special air freight premiums incurred are the responsibility of the customer. Contact Customer Service with questions regarding your options when using these premium shipping services.
- **Because all finishing materials are flammable**, they are classified as Hazardous Materials by the shipping industry. Although limited quantities of finishing materials can be shipped by air, shipping charges are extremely expensive. Finishing materials shipped by common carriers require special handling designated by the shipping industry. Additional Hazmat charges will be assessed and are the responsibility of the customer, and will be added to your freight costs.
- **Many common carriers** have implemented a surcharge for large packages including those over 96" in length. Conestoga will select the most economical shipping method to minimize this surcharge. Conestoga will not charge the surcharge for packages delivered on our company-owned fleet trucks.
- **Orders placed separately** are not guaranteed to ship together, even if a requested ship date is supplied by the customer.

Drawer Box and Cabinet Systems Orders

- If you are located in the following states: AL, FL, GA, MS, NC, SC or TN your order will ship from our Kenly, NC facility, all others will ship from our East Earl, PA location.
- Expedites will ship direct from our Kenly, NC facility. These costs are the responsibility of the customer.

Cabinet Systems Packaging

Standard Box Packaging

- All Advantage and Vesta Cabinet Systems units are individually boxed making it easier to move one cabinet at a time. Most parts for one unit are in the same box. Larger cabinets are packaged in multiple boxes for easier handling.
- Boxes are placed on skids, stretch-wrapped, and banded for shipping.
- Doors and drawer fronts are packaged separately from the cabinet units.
- Assembled drawer boxes, drawer slides, hinges, and shelf rests are shipped on a separate skid from cabinet units.
- This packaging method generates a considerable amount of cardboard boxes, inserts, and plastic strapping that need to be discarded/recycled.

Skid Pack Packaging

- The Skid Pack Packaging Option is available for Advantage Cabinet Systems and must be requested by the customer. A minimum of five cabinets is required for skid packaging.
- Advantage cabinet units are packaged on a 44" x 54" skid with a sheet of cardboard separating each cabinet.
- Skids are reinforced with cardboard, stretch-wrapped, and prepared for shipping.
- All cabinets are individually labeled with the Cabinet code and size.
- Drawer boxes, drawer slides, and hinges are packaged separately.
- Custom doors, drawer fronts, and front frames are shipped on a separate skid from cabinet units.
- The entire order may be consolidated onto a single skid, depending on its size and selected options.
- Approximately twenty cabinets can be placed on a skid.
- Adequate receiving facilities and handling equipment (loading dock, forklift, skid jack, etc.) must be provided. Note that the product cannot be carried by hand off the skid during the receiving process.
- Customers who pick up their orders from a Conestoga facility must have a truck capable of accepting palletized products.
- With less labor needed to unpack cabinets, customers may experience considerable labor cost savings.
- Skid Pack Packaging requires fewer cardboard boxes and plastic banding to discard; customers may see a significant decrease in waste disposal costs

Handling & Packaging Upcharges

- Small order quantity charge: A net charge will be included for small quantity orders containing 1 to 3 pieces. This charge is necessary to offset costs associated with processing, handling and packaging small quantity orders and will be assessed on all custom product orders, including expedites. Cabinet Systems orders and Cabinet Systems parts orders are exempt from this fee.
- Oversize packaging charge: Oversized products will be packaged using honeycomb cardboard to protect against shipping damage. A product will be considered oversized if it meets one of the following criteria:
 - ♦ Dimensions exceed 36" in width and 36" in length.
 - ♦ Dimensions exceed 84" in width or 84" in length.

Each oversized product will incur a net charge for packaging. Customers requesting oversize packaging will also receive the per piece net charge. Mouldings and Cabinet Systems parts will not be included in the oversize packaging program and are exempt from this fee.

Conestoga Freight Terms

- Open Credit Terms
 - ◆ Customers with open credit terms will be shipped prepaid via common carriers. A “freight only” invoice will be generated by Conestoga per delivery.
 - ◆ All orders that ship via Conestoga route truck service will be consolidated and one “freight only” invoice will be generated per delivery. Rates vary by zone and weight.
 - ◆ FedEx Ground and UPS Ground will be shipped prepaid and the charges will be added to each invoice.
- 100% Pre-pay
 - ◆ Customers will be charged for shipping at the time the order is placed.
 - ◆ Conestoga will estimate the weight of the order and utilize a zone freight matrix to determine freight charges.

Customer Pick Up

- A 2.5% handling fee is added to all customer pick up orders due to staging, storage and double handling of the product. All customer pick ups must be scheduled through Customer Service at least four business hours prior to the desired pick up time. Customers picking up their own orders are asked to do so within three days of the acknowledged ship date.
 - ◆ **Customers are required to schedule a pick up time with Customer Service. Warehouse hours of operation are 7:00 a.m. - 11:30 a.m. (EST), Monday through Friday.**

Customer Receiving Process

- For Conestoga route truck deliveries, Conestoga drivers will assist you in verifying that you have received all products listed on a skid report. The skid report documents each skid number and the number of packages on each skid. Any oversized or loose packages will also appear on the skid report. Your receiver will be asked to sign the skid ticket and Bill of Lading as verification that delivery of all packages listed has occurred.

Damaged and Defective Product Policies

- Notify Customer Service within 15 business days after receipt of shipment if you receive products that are damaged, defective or in error. Submitted claims must include the following information:
 - ◆ Original order and invoice numbers.
 - ◆ A list of the defects or errors in the product(s).
- Returns of non-defective merchandise will not be accepted.
- Conestoga will ship replacements or missing items as soon as possible after a claim is reported. Replacement product(s) will be invoiced at the original product cost. A credit will be issued against the original Purchase Order once the claim has been investigated and the product has been deemed defective. In some instances, Conestoga may require that the defective product be returned for inspection prior to a credit being issued, but this will not impact the lead-time of the replacement item.
- A copy of our Return Merchandise Authorization Form, supplied by Customer Service, must accompany all returned merchandise.

Return Merchandise Authorization (RMA)

- Because our products are custom manufactured from natural materials, we will occasionally ask to have incorrect products returned for quality inspection. This inspection process is necessary to identify how the issue occurred and to improve our overall quality and delivery performance.
- Customer Service will issue a Return Merchandise Authorization (RMA) form to you via e-mail, automated fax acknowledgement or mail. This RMA form will list the products that you have identified as defective. **Please mark your return cartons and boxes with the RMA number listed on this form.**
- All returned merchandise must be shipped with secure, protective packaging materials.

Freight Damage Claims

- **If a Common Carrier or freight shipment contains a damaged package or skid, the freight bill must be marked "DAMAGED". Both the receiving customer and delivery person must sign the freight document. If the freight bill contains no notation of damage, or is lacking the appropriate signatures, the freight carrier will deny the claim. Pictures of both the damaged box or pallet and the damaged product inside are necessary to file a claim with a carrier.**
- Conestoga will process all claims for damaged products shipped on Conestoga's trucks and our preferred common carriers (Ward, FedEx Freight, AAA Cooper and Averitt Express).
- Common carrier claims must be filled out by Conestoga with the appropriate freight carrier. Conestoga will replace damaged items with no expedite upcharges.
- FedEx and UPS Ground damage claims must be filed by Conestoga and will be paid to Conestoga. Valid claims will be credited to the customer. All packaging materials and damaged product must be retained by the customer for inspection or collection by the carrier.
- Damaged product must be reported within 15 business days after receipt of product. Claims for damaged product after 15 days may be denied.

Missing Product Claims

- For missing product claims, Conestoga will initiate an investigation of the original shipment. The research will include our picking documents, skid listing and Bill of Lading. These documents will verify if the proper number of products were loaded on the delivery truck. The Bill of Lading will show proof of delivery or notations of any delivery or receipt issues.
- Based on the results of the investigation, Conestoga will either issue a credit to your account or notify you that your claim has been denied.
- Conestoga requests that customers verify the package count within 5 business days, and the total number of items and product sizes within 15 business days. Claims filed for missing products after 15 business days may be denied.
- If any portion of a shipment is lost, 7 business days must be given to locate it.

Replacement Order Process

- A Replacement Order Form can be downloaded from the Supporting Product Information of the CBP or supplied by Customer Service.
- Replacement orders will be processed as quickly as possible. See the Replacement Expedite Program Chart in the Offerings Section of this manual for details.
- All replacement orders will be processed according to the customer's normal payment terms.
- A credit will be issued against the replacement order for all replacement items.

Product Warranty Information

- Conestoga Wood Specialties Corporation warrants that, for a period of one year from date of shipment, our products will be reasonably free of defects in materials and workmanship. When properly handled, our products will conform, within acceptable tolerances, to applicable manufacturing specifications. This limited warranty applies only to Conestoga products which are stored, handled and installed properly. Conestoga will not be responsible or liable for any indirect, consequential or incidental damages or costs sustained by the user.
- Conestoga's warranty is limited solely to the value of the original materials purchased from Conestoga and is further limited in amount to the purchase price paid for such materials. Conestoga will not be liable for the cost of extraneous materials, labor, travel costs, installation expenses or other related expenditures.
- Conestoga will not be liable for damages to products caused by improper handling, storage, assembling, finishing or installation by the customer. Our products are not warranted against expansion occurring as a result of high moisture or humidity conditions.
- Natural characteristics in the wood (burls, grain patterns, pin knots, mineral deposits, sapwood, etc.) that fall within Conestoga's specifications will not be considered defects.
- Most wood species, particularly Cherry, will darken naturally with age. Conestoga is not liable for the change in appearance of any product, finished or unfinished, due to this aging process. Results of aging will be more obvious when using light colored or natural finishes.
- Mitered doors allow a .010" joint gap on the interior corners of the door for up to 1/3 of framing to allow for the expansion/contraction due to seasonal changes.
- Mitered doors are not warranted against joint separations that occur as a result of high humidity or moisture conditions.
- Veneered panel doors are not guaranteed to match solid wood framing on the same door in either the raw or finished state.
- Solid wood moulding color may differ from doors of the same specie.
- Because the individual staves of the panel continue to contract and expand, lines may appear on solid wood panels and offsets may develop from one stave to another. These stave lines will not be considered defective. **To eliminate the chance of stave offsets, utilize the MDF panel option when using painted finishes.**
- Vertical grain panels that exceed 22" wide by 43-15/16" high or horizontal grain panels that exceed 43-15/16" wide by 22" high in either single or multi-panel products are not warranted against expansion, warpage, cracking or open framing joints.
- Conestoga will warrant 1-piece products against expansion, warpage or cracking if they are within the following parameters:
 - ◆ Product up to 12" wide and 21-15/16" high will be warranted if the expansion or warpage is greater than 1/8".
 - ◆ Products measuring between 12-1/16" to 22" in width, or 22" to 43-15/16" in height will be warranted if the expansion or warpage is greater than 1/4".
 - ◆ Any 1-piece product exceeding 22" in width or 43-15/16" in height will not be warranted.
- All solid wood 3-piece drawer fronts over 44" wide or 14" high are not warranted against expansion, warpage, cracking of panels or cracked joints.
- Conestoga expressly disclaims any and all other warranties, whether expressed or implied, including all warranties of merchantability and warranties of fitness for a particular purpose with respect to its products.
- Allowable tolerances of bow, warp or twist for single panel, multi-panel, frame only and mullion doors are as follows:
 - ◆ Single panel up to 26" wide and 48" high = 1/8".
 - ◆ Multi-panel up to 26" wide and 48-1/16" to 64-15/16" high = 1/4".
 - ◆ Multi-panel up to 26" wide and 65" to 83-15/16" high = 5/16".
 - ◆ Single panel, single opening frame only and mullion doors over 26" wide and 48" high will not be warranted (mullion lites not included in opening count).
 - ◆ Any door exceeding 26" wide or 83-15/16" high will not be warranted.

Finishing Warranty Information

- Conestoga's finishes carry a one-year limited warranty against peeling, blistering or cracking, but no warranty against discoloration. Conestoga assumes no responsibility for damages or poor color match when finish is applied by the customer.
- Most wood species will naturally darken or yellow with age. Conestoga will not be held liable for the change in appearance of any product, finished or unfinished, due to this aging process.
- Conestoga recommends that a finished sample door be ordered prior to ordering any finished job. We do not suggest ordering large or complex finished product based on small sample swatches.
- Conestoga has established an acceptable range of color for finished products. Orders placed over an extended period of time may vary in color due to the natural aging of the finished substrate and slight variations from batch to batch in finish materials. These variations will not be considered defective and will not be warranted by Conestoga.
- Conestoga's finish materials are interior grade only and not intended for exterior use. Exposure to outdoor conditions will cause failure and will not be warranted.
- Due to the many variables involved in any finishing process, Conestoga assumes no responsibility if products stained by the customer using the DuraGuard system do not produce an exact match to prefinished products purchased from Conestoga.
- Painted or opaque finishes are not recommended on mitered designs. To reduce the chance of joint separation, Conestoga recommends using an MDF panel option.
- Veneers will absorb stain differently than solid wood. The mismatch of solid wood and veneers is not considered defective.

Marketing Support Materials

To assist our customers, Conestoga offers a variety of Marketing Support Materials. For a complete list of available materials see the Literature Request Order Form included in the Order Forms Section of the Custom Product Manual.

Product Manuals

Conestoga has two product manuals to inform and educate our customers about the extensive line of components that we offer. Manual pages are three-hole punched to be placed into in three-ring binders so information can be easily located regarding new products and services. Each page is dated and numbered by section, which assists our customers in updating manuals with supplemental product information.

Custom Product Manual: Our Custom Product Manual guides you through the wide range of custom products and options that makes Conestoga the leading supplier of components to the Custom Kitchen & Bath industry. From doors and drawer fronts to a spectacular array of accessories, storage and organizational items as well as a broad selection of specialty products, Conestoga helps our customers build high quality kitchens in a variety of designs and price points.

Cabinets Systems Product Manual: Conestoga's Cabinet Systems include Advantage Framed Cabinetry and Vesta Full Access Cabinetry. Our Cabinet Systems Product Manual contains detailed product information and pertinent information on how we do business with our customers. Information includes cabinet line drawings, standard and custom size ranges, options, finishes, species and more!

An interactive PDF of the Custom and Cabinet Systems manuals is available on the Customer Business Portal under the "Marketing Resources" tab.

Interactive Tools

Customer Business Portal: Obtain a user name and password and visit our online Customer Business Portal at <https://my.conestogawood.com>. This customer-only site allows you to view quotes orders, print acknowledgements and invoices and track shipments 24 hours a day, 7 days a week. You will also find marketing materials such as product literature, various PDF files and drawings you can use as tools to help market your own product lines. Contact Customer Service to sign up today. Con-Nex, our online quoting and ordering software is also housed within our Customer Business Portal.

Con-Nex®: Our order entry software package provides an easy way to obtain instant pricing and electronically place orders. For more information about our online quoting and ordering system, contact Customer Service or your Conestoga Sales Representative.

2Configure: 2Configure design software brings time-saving convenience to selling Conestoga Advantage Framed or Vesta Full Access cabinetry, featuring a wide variety of custom door designs. Easily bring your customer's vision to life - use 2Configure to select cabinetry and door designs. Complete your kitchen layout and generate realistic 3D renderings for your customers to review. As you design, the 2Configure software automatically calculates product costs, and when finalized, the project can be seamlessly placed into Con-Nex and turned into a Conestoga order.
www.advanceware.com/cws

Website: ConestogaWood.com was developed to provide an online look at our wide variety of kitchen and bath components. You'll find images of doors, drawer fronts, cabinet systems, drawer boxes and much more! Use the site as an online brochure to select and compare door styles, profiles, finishes to name a few. Check out the news area for the most up-to-date information about products and our company.

Door Designer: Conestoga's proprietary Door Designer which is accessed through ConestogaWood.com is your opportunity to create a unique door style to suit your taste. This tool allows you to select the material, design options and the finish desired with the ability to view the door design in a kitchen layout. Additionally, once you've created an account, the designs you've created are able to be named by you and can be saved with all the details that you've included for future reference or refinement.

Marketing Support Materials (continued)

Cabinet Assembly Videos

Looking for guidance during cabinet assembly? Conestoga Wood offers easy-to-follow videos to support both our RTA Advantage Framed and Vesta Full Access cabinet lines. Whether you're a seasoned pro or assembling for the first time, these step-by-step resources walk you through the process, helping ensure a smooth and successful build. Explore the full library on our YouTube channel: [YouTube.com/@ConestogaWood](https://www.youtube.com/@ConestogaWood)

Brochures

To assist our customers in their selling efforts, Conestoga offers a variety of printed materials for your convenience.

Finishing Color Guide: Featuring several full kitchens, this generic brochure includes an assortment of species, finish and glaze combinations in both wiping stains and paint options. Void of Conestoga's name and logo, this brochure was designed to supplement your own literature. Minimum of 10 brochures per order. part #2600722A.

Product Brochure: This full-line color, 40-page brochure features many of Conestoga's most popular door and drawer front designs. Complementary products such as drawer boxes, mouldings, and accessories are also included. A variety of finishing options and material information are highlighted in the brochure. Minimum of 10 brochures per order. part #2600705A.

Refacing Brochure: This generic, eight page full-color brochure features door and drawer front designs, mouldings, convenience items along with "before" and "after" photographs of a refaced kitchen. Including all the products a refacer would typically use when upgrading a kitchen, space is provided on the back page of this brochure to put your company's name, address and logo. Minimum of 10 brochures per order. part #2600688A.

Special Designs Brochure: This 20-page brochure features products that are manufactured for premier custom designs. This brochure shows you a sample of what is possible with exotic specie options, impressive mullion and arched valance configurations, specialty door designs, front frames, custom finish matches, etc. Minimum of 10 brochures per order. part #2600645A.

Inspired Design Brochure: This unbranded brochure features 32 door styles and 8 kitchen images. Inspired Design features doors shown in kitchen style categories of Farmhouse, Traditional, Modern, Transitional, Slim Shaker and Shaker. Utilize this brochure as your own, however, it does include Conestoga nomenclature. Minimum of 10 brochures per order. Part #2601362A.

Product Highlight Sell Sheets

These reference sheets are designed to highlight specific product categories and options. Ask your Sales Representative for a copy of the latest Conestoga "Sell Sheets" or visit the Customer Business Portal to download.

Point of Purchase Items

Conestoga offers conveniently packaged Product, Moulding, Profile and Finishing Sample Kits. To view the available kits that assist customers in making selections, see Section 13 of the Custom Product Manual. These valuable tools are ordered using part numbers, with detailed information about what is included within the kits in the Custom Manual. Additionally, the Prism Paint Fan Deck with over 1,600 colors is also available.

Lead-Time Information

Cabinet Systems Products Lead-Times		
Products	Lead-Time in Workdays	
	Standard	Expedite
Cabinet Systems with doors	10-15	4-6
Cabinet only (no doors or drawer fronts)	8-10	2
Cabinet parts	4-5	2-3
Finished cabinets with Colourtones, primers, Truetones and wiping stains	STD + 5-8	STD + 5
Prism Paints – Pastels and Deeptones	STD + 6-8	NA
Prism Paints – Bolds	STD + 8-10	NA
Finished cabinets with wiping stains w/glaze and Colourtones w/glaze	STD + 5-8	STD + 4-5
Custom Drawer Boxes*	7-10	4-5

* See Custom Product Manual for additional information.

All lead-times are subject to change based on incoming volumes and seasonal fluctuations.

Overall order lead-time is determined by the item with the longest lead-time. Refer to our Custom Product Manual for additional lead-times and other ordering specifics on custom products.

General Lead-Time Information

- Lead-time scheduling may be delayed if order placement questions are encountered. Orders with questions will not be scheduled for production until all questions have been answered by the customer.
- Lead-times are based on normal business days, which excludes weekends, company holidays and non-workdays due to acts of nature. Lead-times do not include transportation time.
- Published lead-times are not guaranteed and can vary according to incoming order volume, material availability, capacity constraints, labor requirements and other factors.
- Following the order entry process, each order is scheduled and committed to a production schedule. This process is completed at the end of each day; assuming no questions are encountered, a ship date is assigned to the order. The ship date appears on the order acknowledgement and can be viewed on the CBP (Customer Business Portal).
- Orders containing products with different lead-times are given the ship date of the product with the longest lead-time. Customers wishing to split their orders and receive products when ready must note this on their order.
- When using the Conestoga route truck delivery service, lead-times will vary according to your truck's delivery schedules. Consult Customer Service with route truck questions and schedules.
- Large quantities, complex orders and products processed through our Special Designs Department may experience extended lead-times.

Order Timing

- All standard orders processed with open terms and received by 9:00 a.m.(EST) on a business day will have the lead-time begin that day. Orders received after 9:00 a.m.(EST) will have the lead-time begin the following day.
- 100% pre-pay orders will begin the manufacturing process one business day after receipt of payment. Lead-time calculations begin upon the receipt of payment, **not receipt of order**. Orders prepaid using American Express, Discover, MasterCard or Visa obtain faster approval.

Expedite Programs

- Conestoga's expedite program is designed to aid our customers in **emergency** situations where product is needed to complete a job. The expedite program lead-time is based on available capacity.
- Expedite charges are based on the net amount of all products ordered before shipping, special handling and taxes are applied. Expedite charges are shown as a line item at the bottom of both the acknowledgement and invoice.
- Code Green expedites can only be used with Cabinet Systems orders. These expedites ship in 4-5 days, with a 35% upcharge. There is a six piece limit on Cabinet Systems Code Green expedite orders.
- Expedite orders received prior to 11:00 a.m.(EST) will be eligible to go into production the same day. Any expedite order received after 11:00 a.m.(EST) will be eligible to go into production the following day.
- The expedite lead-time for a custom door ordered with Cabinet Systems products will be based on the door design.
- Orders containing products with different lead-times will be given the lead-time date of the longest product.
- Finished products can be expedited. To calculate the lead-time take the product expedite lead-time and add the standard finishing lead-time.
- All expedite upcharges are calculated on a "percentage of the order" basis. More detailed information can be found within the relevant lead-time charts.
- Every item on an expedited purchase order will be subject to the upcharge. To expedite only a few items, separate those items onto a different purchase order.
- For additional information regarding our expedite programs, see the Lead-Times Section of the Custom Product Manual.

Replacement/Re-Order Program Lead-Time

- Products incorrectly produced by Conestoga will be replaced with no expedite upcharges.
- Customer re-orders must contain products that were previously ordered. All re-order requests must be submitted in writing and include the original sales order and line numbers that are being re-ordered.
 - ◆ Individual products damaged or incorrectly ordered by the customer will be replaced as a Code Red expedite with no upcharge.
 - ◆ Entire orders of damaged or incorrectly ordered doors and drawer fronts by the customer will be replaced as a Code Blue expedite in approximately half the standard lead-time with no upcharge. See replacement Lead-Time in the Custom Product Manual for more information.
 - ◆ Cabinet Systems products damaged or incorrectly ordered by the customer will be replaced as a Code Green expedite with no upcharge.

Replacement Expedite Program (Customer Issues)				
Products	Expedite Code	Upcharge Rate	Restrictions	Lead-Times
Cabinet Systems	Code Green	No Upcharge	6 cabinet limit	See Lead-Time chart
Custom Drawer Boxes 5/8"	Code Green	No Upcharge	6 box limit	
Custom Front Frames	Code Red	No Upcharge	6 piece limit	
Custom	Code Blue	No Upcharge	30 piece limit	

Cabinet Systems Door and Drawer Front Specifications

Both the Advantage and Vesta Cabinet Systems programs offers a wide variety of Conestoga's 3/4" thick custom door and drawer front designs. From transitional to traditional to contemporary and beyond, more than 100 door design options are available. The full array of door and drawer front designs as well as related details and options can be found in our Custom Product Manual.

- **Door Designs:** Nearly all of Conestoga's 3/4" thick doors and drawer front designs are available with the Cabinet Systems program. This includes eligible framing bead, panel raise and edge profile options available with each design.
- **Door Species:** All published specie and grade combinations are included in the Cabinet Systems program. These grades include Premium, Standard, Paint Grade, Rift Cut, Quarter Sawn and Rustic Knotty grades. For painted finishes Conestoga recommends doors and drawer fronts be ordered in Paint Grade Hard Maple, Paint Grade Hard Maple Hybrid or MDF for best results. Cabinets utilizing Exposed Ends and Matching Interior Options are limited to Standard grade Cherry, Hard Maple and Red Oak, as well as Paint Grade. For a complete list of species and cabinet and trim options see Section 5, Advantage Specifications and Section 13, Vesta Specifications for each cabinet lines' unique features.
- **Alternative Materials:** The Vesta Full Access Cabinet line offering includes all Allure DLV, Intrigue TTS, Strata TTS, Vogue TTS, Synchrony High Gloss and Synchrony Super Matte door programs. The Matching Case Color Option is limited to the Intrigue, Strata and Vogue TTS programs. A complete listing of cabinet and trim options is located in Section 13, Vesta Specifications.
- **Door Thickness:** Both the Advantage and Vesta Cabinet Systems programs can be paired with nearly any of Conestoga's 3/4" thick door designs. Doors thicker than 3/4" are not compatible with the Blum COMPACT framed hinge or INSERTA frameless hinge and are not eligible to be ordered in conjunction with either program. If doors and drawer fronts thicker than 3/4" are desired, Conestoga will configure and size the doors and drawer fronts for the appropriate cabinets, but customers must omit the Blum COMPACT or INSERTA hinges when ordering. Customers are responsible for supplying their own 1" hinges.
- **Door Overlays:** The Advantage Framed RTA program offers four standard overlays as well as an inset door option. The standard overlays include 1/4", 1/2", 1-1/4" and 1-3/8". The Vesta Full Access program offers only full overlay doors and drawer fronts. Diagrams showing the different overlay dimensions and spacing between doors and drawer fronts, and the distance between the door's edge and the exterior edge of the cabinet can be seen in Section 5, Advantage Specifications and Section 13, Vesta Specifications.
- **Multi-Panel Doors:** Multi-panel doors manufactured with upper and lower panels have the option of different designs for each panel. For instance, if the wall cabinet doors have an arched panel door design and base cabinets have a square panel door design, the upper panel of the multi-panel door can match the arch of the wall cabinets, while the lower panel can match the square base cabinet doors. If not specified, both the upper and lower panels will be manufactured with square panels.

Specie and Grade Characteristics

Why Have Different Grades?

Conestoga has developed different grades of material to utilize our natural resources to the fullest. These distinct material grades have been established, allowing you to choose the best alternative for a particular job or finish.

Premium

Conestoga's Premium grade has been developed for those jobs where a more uniform look is needed. This grade contains less of the natural material characteristics and is produced within a more uniform color range.

Premium orders will be matched to obtain a look that is as uniform as possible. However, since each board is different, there may be slight differences in appearance and color between pieces. Premium products will contain fewer and smaller mineral streaks and pin knots than Standard grade. A Premium grade order will give you a job that is consistent throughout for color and material characteristics.

In Heartwood species, such as Cherry or Red Oak, no sapwood will be seen on the face of the door; in Sapwood species, such as Hard Maple, no heartwood will be seen on the face of the door.

Conestoga recommends Premium grade for natural and light tinted finishes.

Hickory is an exception to our normal Premium grade guidelines in that the color variations and lack of uniformity are a characteristic of Hickory. A Premium grade of this specie will include a narrower range of variation and fewer natural characteristics, but will not be uniform in heartwood or sapwood color.

Standard

Conestoga's Standard grade has been developed to meet a wide variety of applications and will provide a very versatile product at a reasonable cost. Standard grade material allows for many of the natural characteristics of the wood to be present in the product while limiting or eliminating the most objectionable. This material grade allows Conestoga to utilize as much of the natural resource as possible while still producing a product that meets the needs of our customers.

Even though each board has its own unique color and grain, staves will be matched for a pleasing appearance. Colors will be blended within each door. Character marks such as pin knots and mineral streaks are limited in size.

At times, vertical cuts will cross glue lines and may leave exposed glue on the edges of the product. While this is common in all species, the glue used in the production of Bamboo is dark in color and may be more apparent than is typical on hardwoods. Visible glue on the edges of Bamboo product is not considered defective.

In Heartwood species, such as Cherry or Red Oak, the amount of sapwood that is present on the face of a door is limited and will only be present in the profiled areas. Sapwood species, such as Hard Maple, limit heartwood to the machined areas.

Conestoga utilizes steamed Walnut. The steaming process turns light colored sapwood to grey. Conestoga's Standard grade Walnut allows a mix of heartwood and grey sapwood throughout both the face and profiled areas of the product. This grade is recommended for medium and dark finishes on Walnut. If no sapwood is desired, order Premium grade Walnut which eliminates all sapwood from the face.

Standard grade works well with most finishes. Light tinted and clear finishes will accentuate the natural characteristics and color differences within the product. Two or more sample doors should be ordered and finished prior to ordering an entire kitchen.

Specie and Grade Characteristics (continued)

Paint Grade Hard Maple

Conestoga's Paint Grade Hard Maple was developed specifically for those customers that prefer to use only Hard Maple components for paint applications. This grade will allow natural color range of Hard Maple including stain heartwood and mineral. Products made from this grade will not be matched for color, with heartwood and sapwood present in varying amounts. Knots, wormholes and other defects that would cause voids are limited, providing a smooth paintable surface. This grade is intended for painting only and is also available with an MDF panel option.

For painted kitchens Conestoga recommends Paint Grade Hard Maple Hybrid, or 1-piece and 5-piece MDF products. See Specifications, Section 3 in the Custom Product Manual for details about these offerings.

Other Grade Options

Conestoga offers a variety of other wood grades including Rustic Knotty, Rift Cut, & Quarter Sawn. See table below for Specie / Grade availability.

Specie	Grade Availability				
	Premium	Standard	Rustic Knotty	Quarter Sawn	Rift Cut
Alder	No	Yes	Yes*	No	No
Bamboo**	No	Yes	No	No	No
Birch, Red	No	Yes	No	No	No
Birch, White	Yes	Yes	No	No	No
Cherry	Yes	Yes	Yes*	No	No
Hickory	Yes	Yes	Yes*	No	No
Mahogany	No	Yes	No	No	No
Maple, Hard	Yes	Yes	Yes*	No	No
Maple, Soft	No	Yes	No	No	No
Oak, Red	Yes	Yes	Yes*	No	Yes*
Oak, White	Yes	Yes	No	Yes*	Yes*
Paint Grade	No	Yes	No	No	No
Paint Grade Hard Maple	No	Yes	No	No	No
Pine, Clear	Yes	No	No	No	No
Pine, Knotty	No	Yes*	No	No	No
Walnut	Yes	Yes	No	No	No

* All mouldings will be clear; Knotty Pine, Quarter Sawn, Rift Cut and Rustic Knotty mouldings are not available.

** Bamboo products are limited to 95-3/4" in length and 47-1/4" in width when ordering vertical grain or 47-1/4" in length and 95-3/4" in width when ordering horizontal grain.

Finishing Program Overview

- Conestoga’s finishing capabilities allow our customers to simplify their shop process by eliminating the finishing of doors, mouldings, face frames, end panels and other products. Outsourcing finishing ultimately reduces VOC emissions and helps streamline throughput by minimizing the finishing bottleneck.
- Conestoga’s Cabinet System’s finishing program consists of traditional wiping stains, Truetones, Colourtones, Prism Paints, glazes, primers and topcoats. Combined, these finish options create a palette of over 1,800 unique combinations.
- Conestoga has two topcoats available: 10° (low sheen) and 30° (medium sheen). Topcoat glosses will not be custom matched.
- In addition to our standard colors, custom color matching is available for wiping stains. Consult the pricing page in this section for information on custom color charges.
- **We strongly recommend that sample doors be purchased in the desired specie, color and design prior to placing full kitchen orders. This will ensure that the chosen combination meets your expectations.**

Finishing Process

- Prior to finishing, Conestoga’s doors, drawer fronts and front frames are sanded on an automated sanding line to deliver a smooth, “finish-ready” product.
- To apply wiping stains and glazes, Conestoga uses a time-proven, hand-wiped technique which delivers more color consistency and depth than simple spray stain applications.
- Most Conestoga framing beads are designed with a slight back bevel, which allows the stain to penetrate beyond the juncture of the framing bead and panel raise. During the wiping stain process an air nozzle is used to blow stain under the framing bead, minimizing the possibility of “white line” appearing on the panel during expansion and contraction. All doors are matched to a control sample for color consistency during the staining process.
- After staining or painting doors and cabinet components receive a sealer and topcoat. Our sealer is a high solids material that is applied and then sanded with a fine grit sandpaper after drying. The final coat is the application of a high solids conversion varnish topcoat in either 10° or 30° sheen. Conversion varnishes provide a superior finish with exceptional clarity, resistance to moisture and excellent overall durability. Conestoga has selected the topcoat sheen that generally provides the most pleasing appearance for each finish type. However, in some cases customers do have the option of selecting an alternate topcoat sheen with no upcharge.
- Colourtones and Prism Paints are applied using air assisted, airless spray equipment.
- After curing, parts are inspected before being packaged for delivery to our customers.

Finish Type	Standard Sheen	Optional Sheen
Colourtone	10°	NA
Colourtone w/glaze	10°	NA
Prism Paints	10°	NA
Truetones	10°	30°
Truetones w/glaze	10°	30°
Weathered Grain (all)	5°	10°
Wiping Stains	10°	30°
Wiping Stains w/glaze	10°	30°

Finishing Tolerances

- Conestoga’s finishing tolerances are designed for solid wood applications. Application of finish on plywood, veneers, decorative accent items and MDF may result in some color variation. Similarly, finishes applied by the customer may vary slightly from those products finished by Conestoga. See the DuraGuard System information in this section for loose finish purchase information. Instructions for application are also published in this section and enclosed with DuraGuard finish orders.
- Conestoga cannot predict how a door or cabinet part will accept finish. Therefore, if a piece meets our material specification standards in its unfinished state, it will be considered acceptable after finishing as well.

Finishing Warranties

- Conestoga's finishes carry a one year limited warranty against peeling or blistering, but no warranty against discoloration. Conestoga assumes no responsibility for damages or poor color match when finish is applied by the customer.
- Most wood species will naturally darken or yellow with age. Conestoga will not be held liable for the change in appearance of any product, finished or unfinished, due to this aging process.
- We strongly recommend that a sample door be ordered in the desired specie, design and finish prior to ordering a full kitchen, regardless of the finish and specie combination.
- Conestoga's finish materials are interior grade only and not intended for exterior use. Exposure to outdoor conditions will cause failure and will not be warranted.

Wiping Stains

- All Conestoga wiping stains are applied using a hand wiped application. The process provides superior grain penetration of the finish material and a greater degree of depth.
- Alpine wiping stain is not available over certain darker, high contrast species such as Mahogany or Walnut.
- Conestoga does not recommend darker finishes such as Espresso or Dark Roast over light species such as Hard Maple or Soft Maple. The contrast, as well as the properties of these species may create a blotchy, uneven look. Therefore, these combinations are Not Recommended (NR), but can still be produced with a 20% upcharge on the Design Charge and no warranty on color consistency.
- Because Conestoga uses wiping stains, and wiping stains penetrate into the wood grain, end grain will stain and glaze darker than other areas of the piece. This end grain contrast will not be considered defective.

Note: Utilizing Conestoga's End Grain Sealant Option will minimize end grain contrast.

Custom Wiping Stain Match Program Guidelines

- A representative sample of the custom stain color and specie to be matched must be provided. Prior to shipping the color sample to Conestoga, customers must contact Customer Service to obtain a Return Merchandise Authorization (RMA) number that must be included with the sample being submitted, along with a Custom Wiping Stain Match Form found at the end of this section and on the Customer Business Portal. A non-refundable net fee will be invoiced when the custom stain sample is received from the customer. Conestoga will not begin the matching process unless a Purchase Order has been provided. The matching fee applies regardless of whether the match is approved by the customer. Allow 10 business days for the completion of individual color matches.
- Accompanying the custom stain sample will be a Stain Match Approval Form. If the match is acceptable, sign and return the Approval Form to our Finishing department and we will assign a custom color mix number. This unique finish number must be referenced each time an order is placed for the custom stain. A custom stain Design and Finishing Material Charge applies to each order.
- At times, customers submit multiple stain matches for a similar color with the intention of selecting only one match. On these occasions, a net matching fee will apply to the primary stain match request, and a net fee for each subsequent stain match requested. This reduced matching fee applies only when each of the stain colors are relatively close in appearance and submitted at the same time. Any stain not close in color to the primary submission will be invoiced at the net fee. If an additional stain sample is submitted at a later date, it will be invoiced at the net fee, regardless of whether the stain is close in color to a prior submission.
- Frequently, we receive requests for multiple species with a stain match, or to add additional species and/or glaze treatments to a previously approved stain match. When these requests are received, Conestoga will generate a hard sample of the approved custom stain on each new specie or requested glaze. A Purchase Order number must be submitted along with the request as a net fee per individual request will be invoiced at the time the sample is received from the customer. Conestoga will retain a portion of the sample to serve as a control sample to be used for future production needs.

Custom Wiping Stain Match Program Guidelines (continued)

- Custom stain mixes are kept on record as long as the finish continues to be used. If no orders for a custom stain are placed for a period of 1 year, the mix will be voided. This guarantees our customers a truly unique stain since it is matched to their exact specifications. Conestoga will only custom match wiping stains and will do so using pigmented wiping stain materials.
- Conestoga offers two topcoat glosses, 10° and 30°, with no option to custom match glosses.
- Quarts and gallons of custom stains can be purchased. Call Customer Service for pricing.

Truetones

- Conestoga's Truetone program consists of both High and Low complexity colors.
- Low Complexity Truetones are lightly pigmented spray to color stains that include a small percentage of solids. They produce a very clean look, with minimal blotchiness. After the Truetone application, a sealer and conversion varnish topcoat are applied.
- High Complexity Truetones are a selection of deep, rich colors that are achieved through a two step application process. The first step is a hand wiped custom stain that brings out the color depth and grain clarity followed by a delicate application of a low solids spray stain. After this two-step application a sealer and conversion varnish topcoat are applied.
- Truetone finishes are available with Brown, Onyx, Oyster and Sable glazes.
- Specie availability with Cabinet Systems products includes Cherry and Hard Maple.
- Color range in an identical stain will vary from specie to specie, sometimes significantly.
- Glazed and Non-Glazed Truetone finishes receive a 10° sheen topcoat standard; however, 30° sheen topcoat is available for Non-Glazed Truetone finishes, but must be specified when placing order.
- Due to the haloing issue associated with applying spray stains to Square framing beads, Conestoga will not apply Truetone finishes to any product using our standard Square framing bead. However, products utilizing a shallow version of the Square bead are eligible to receive Truetone finishes.
- Normal contraction and expansion of the panels may cause unfinished areas to become visible. Normally hidden by the framing bead, this visible unfinished area is known as "white line" and are not considered defective.
- Profiled areas may appear lighter in color than flat areas on both Low and High Complexity Truetones because of the color application process. The effect could be enhanced by certain profiles, such as a Square framing bead, deep grooves and anywhere there is a defined change in the plane of the part. Selecting a glaze option will minimize this effect on any Truetone color.
- As with any stain, veneers will absorb finish materials differently than solid wood. This absorption difference may result in a slight variation in appearance between solid wood and veneered components and is not considered defective.
- Truetones range in color from light to dark. Therefore, they may or may not possess the ability to disguise material variations as well as wiping stains. The use of Premium grade material will mitigate some of these variations.
- End grain will appear darker than non-end grain areas, even when a glaze is applied.
Note: Utilizing Conestoga's End Grain Sealant Option will minimize end grain contrast.

Wiping Stains and Truetones with Hand Wiped Glazes

- All Conestoga hand wiped glazes are applied using a hand wiping application process to the entire surface of both the face and back of every door and all applicable cabinet parts.
- Hand applied glazing is a very subjective treatment. Each product becomes "one-of-a-kind" and unique in appearance and could vary slightly from part to part but will blend within a job. Conestoga matches every glazed part to a control sample, however, color consistency is difficult to control with hand wiped glazed finishes. Some factors that influence color consistency of hand wiped glazed products are door design, profiles, grain patterns, wood density, base color and pre-glaze sanding processes. Conestoga will not warrant these variations and considers them to be acceptable on hand wiped glazed products.

Wiping Stains and Truetones with Hand Wiped Glazes (continued)

- We recommend that our customers develop a document that would be read and signed by the designer or end user indicating their understanding of the potential color issues with any stain and glazed finish. Such a document will help set customer expectations and protect all parties in the event of a color-based issue.
- **Conestoga strongly recommends that a sample door be ordered in the desired design, specie and finish combination prior to ordering a full kitchen.**
- Conestoga maintains strict standards for its glazing processes. With this in mind, Conestoga will not custom match glaze colors or glaze placement. Therefore, we offer only our standard glaze color options.
- Wiping stains and Truetones with any glaze treatment receive standard 10° sheen topcoat; however, 30° sheen topcoat is available but must be specified when placing order.
- Hand wiped glazes significantly alter the appearance of a stain/specie combination. An attractive finish may look quite different once glazed. With this in mind, Conestoga does not recommend certain finish/glaze/specie combinations, and some combinations are not available. See the Offering and Availability Charts in this section for details.
- Conestoga's standard hand wiped glaze offering is available in combination with some custom wiping stain finish matches. For availability of glazing with custom stains, contact our Finishing Department (717) 445-3252.

Primed Products

- Conestoga's priming capabilities allow you to outsource the time consuming process of prepping and priming your doors, drawer fronts, mouldings and Cabinet Systems parts. Outsourcing primed products reduces your company's VOC emissions and increases the efficiency and throughput of your finishing area.
- Conestoga offers three substrate materials with our Cabinet Systems Standard Primer Option:
 - ♦ Solid wood – Cherry, Hard Maple, Red Oak and Soft Maple Custom products are available in a wide variety of designs.
 - ♦ Hybrid products – hybrid products utilize Paint Grade Hard Maple framing in combination with 48-pound density MDF center panels. All published 1/4", 3/8", 5/8" and 3/4" center panels are available in MDF for use in a wide variety of wood framed door and drawer front designs.
 - ♦ MDF – a 48-pound density MDF material. MDF products are limited to Slab, 1-Piece and 5-Piece designs. See the MDF & Alternative Materials Section of the Custom Manual for options.
- Conestoga's primers are post catalyzed, acid cured and compatible with many high quality topcoats. Our Standard Primer application is available in white, light grey, medium grey, dark grey, sage and black.
- Prior to priming, the substrate is prepared to accept the coating material. Putty is applied to the joints, open-end grain, tear outs and other visible voids. The product is then hand sanded to remove excess putty and provide a smooth, uniform surface to accept the primer coat.
- Most Conestoga framing beads are designed with a slight back bevel to allow some primer material to penetrate beneath the framing bead. However, due to the high solids content of the primer itself, bridging of the primer material may occur between the panel and the framing bead on 5-Piece products. Moderate bridging is not considered a defect.
- After curing, all components are inspected, individually wrapped, then packaged and shipped.
- There are many finishes available to paint residential cabinetry. While many of these products may work in combination with our primers, we recommend **only acid cured conversion varnish topcoats**. Testing for compatibility and adhesion between Conestoga's primers and the customer's finish materials should take place on a test door prior to finishing any large items or multi-piece projects.
- Customers should scuff sand the primer using 280-grit sandpaper no more than 24 hours before applying any finish. All surfaces must receive this sanding step to achieve a mechanical bond.
- Conestoga's primed products receive putty prior to application of primer. Smaller voids will become apparent after the primer has been applied. These voids are acceptable and will require a second application of putty by the customer prior to painting.

Primed Products (continued)

- Conestoga's primed products are subject to some natural grain raise during the priming process, which is not considered defective. Normal sanding preparation for topcoat application will remove these wood fibers.
- Conestoga's primed products are manufactured using substrate materials that will expand and contract with fluctuations in climate, temperature and humidity. The movement of the substrate may cause fracturing of the primer anywhere sub-components have been joined together. This fracturing is not considered defective and will most likely occur in the following areas:
 - ◆ Framing joints – where the stiles meet the rails on the face, back and edges of multi-piece products including front frames.
Note: To decrease the chance of joint separation, utilize the MDF center panel option.
 - ◆ Edge profiles – in both mitered and mortise and tenon joint construction at the exterior edges of the product.
 - ◆ Center panels – where the panel recesses into the framing. Bridging of the coating materials can occur between the panel and framing. Natural expansion and contraction of the substrate may fracture the bridging.
 - ◆ Panel face – where individual adjacent staves in the panel expand and contract at different rates causing minor offsets or highlighting of glue joints. Because the individual staves of the panel continue to contract and expand, lines may appear on solid wood panels and offsets may develop from one stave to another. These stave lines will not be considered defective.
Note: To eliminate panel stave offsets, utilize the MDF center panel option.
- Primed products are individually wrapped, minimizing scuff marks.
- Testing for compatibility and adhesion between Conestoga's primers and customer's finish materials should take place on a test door prior to finishing any large items or multi-piece projects. Conestoga assumes no responsibility for incorrect application of finish materials by the customer that may result in poor adhesion, color mismatch or other finish related issues. Conestoga will not warrant products due to incompatibility issues between our primers and non-DuraGuard finish materials.

Colourtones

- Colourtones are opaque finishes, identical in appearance to paint. The coatings are pigmented basecoats that must be catalyzed prior to application. Colourtones require the application of a clear coat of conversion varnish as the final coat.
- Colourtones have a high solids content, resulting in better build and lower VOC emissions.
- Colourtones with Cabinet Systems are available on Cherry, Hard Maple, Red Oak and Soft Maple.
- We recommend adding the Antiquing Option when Colourtones are ordered with Cherry. Characteristics common to Cherry, such as pin knots, mineral and pitch pockets will be present in finished products. The presence of these characteristics will not be considered defective. Refer to the Offering and Availability Chart in this section for species, finish and glaze availability.
- The machining of end grain or MDF on certain profiles may result in those surfaces being porous and the finish on these surfaces may not be as full as the finish on non-machined areas.
- Minor flaws such as dust particles, dimples and lint are more apparent with opaque finishes than with wiping stains. The presence of small amounts of these minor occurrences will be considered acceptable.
- Coatings containing high solids are susceptible to bridging between the framing and center panel. Bridging occurs when the coating material joins the two separate surfaces together. This condition is common between multiple component products and is not considered defective. Over time, the natural expansion and contraction of wood may cause this bridging to fracture.
- Colourtone products are placed on drying racks after the coating application process. Small indentations or pin marks from drying racks may appear on the backs of Colourtone products and are not considered defects.
- Colourtones may vary slightly from one batch to another, but will remain within a controlled color range.

Colourtones (continued)

- All Colourtone finishes will receive a 10° topcoat; 30° topcoat is not available.
- Because Colourtones contain a high percentage of solids, certain characteristics such as joint fracturing will occur. Hairline cracks typically develop along joints on the face, back and edge profiles and can occur during normal handling or from the expansion and contraction of wood. Joint fracturing is not considered to be a defect.
- As with most finishes, Colourtone colors will change over time due to exposure to light, pollution and household chemicals. Additions or replacements to existing kitchens may not initially match finished products already in place.
- Because the individual staves of the panel continue to contract and expand, lines may appear on solid wood panels and offsets may develop from one staff to another. These staff lines will not be considered defective.
Note: To eliminate panel staff offsets, utilize the MDF center panel option.
- Veneer checking and seam separation are inherent characteristics of plywood panels and finished veneers that may appear to be cracks within the coating. These cracks are caused by changes within the veneer and will not be considered defective.
Note: To eliminate veneer cracking, utilize the MDF center panel option.
- Customers interested in purchasing Colourtone finishing materials through the DuraGuard Program should reference DuraGuard Systems information found in this section for coatings pricing and availability.
- When purchasing multiple containers of loose Colourtone coating material, mix the contents of like finishes together prior to adding catalyst to achieve a consistent overall color.
- Catalyst must be added to all Colourtone finishes prior to application. The catalyzation process results in both a limited pot life and a recoat window. Mixture and application instructions are provided near the end of this section.
- We recommend that any topcoat other than DuraGuard products be tested for compatibility prior to application. Conestoga will not warrant products that fail due to non-compatible topcoat materials.
- Conestoga assumes no responsibility for incorrect application of DuraGuard materials by customers, which may result in poor adhesion, color mismatch or other finish related failures.

Prism Paints

- The Prism Paints program offers a selection of over 1,600 opaque colors. Do not place an order for a project utilizing Prism Paints based on the color represented in the fan deck. We strongly recommend a door sample of the actual finish be ordered prior to placing an order for a complete job. Conestoga will not assume responsibility for color related issues resulting from orders being placed without first ordering a sample door.
- Prism Paints may differ in appearance to other types of coatings such as acrylic, latex, enamels or other paint systems with the same color name and number. Both the clear topcoat and spray application will effect texture, sheen and color of this product. It is strongly recommended that a finished sample door in the selected color be ordered prior to ordering a full kitchen.
- Prism Paints are available on 14" sample chips, but not 36" sample chips. A square foot minimum applies.
- Prism Paint coatings are acid catalyzed, pigmented basecoats, much like the Colourtone products. These coatings require the application of a final coat of clear conversion varnish.
- Prism Paints are available on Advantage and Vesta Cabinet Systems. However, Prism Paints with glaze are not available.
- Prism Paints with Cabinet Systems are available on Cherry, Hard Maple, Red Oak and Soft Maple.
- The machining of end grain or MDF may result in those surfaces being porous and the finish on these surfaces may not be as full or smooth as the finish on non-machined areas.
- Minor flaws such as dust particles, dimples and lint may be present with opaque finishes. The presence of a small quantity of these flaws will be considered acceptable.

Prism Paints (continued)

- Coatings containing high solids are susceptible to bridging between the framing and center panel. Bridging occurs when the coating material joins the two separate surfaces together. This condition is common between multiple component products and is not considered defective. Over time, the natural expansion and contraction of wood may cause this bridging to fracture.
- Products having been painted with Prism Paints will be placed on drying racks. Small indentations or pin marks from the drying racks may appear and will not be considered defective.
- Prism Paints may vary slightly from one batch to another, but will remain within a controlled color range. To avoid color variations, order all components for a project at one time.
- All Prism Paints will receive a 10° topcoat, 30° topcoat is not available.
- Because Prism Paints contain a high percentage of solids, certain characteristics such as joint fracturing will occur. Hairline cracks typically develop along joints on the face, back and edge profiles and can occur during normal handling or from the expansion and contraction of wood. Paint fracturing at joints is not considered to be a defect.
- As with most finishes, Prism Paint colors will change over time due to exposure to light, pollution and household chemicals. Additions or replacements to existing kitchens may not initially match finished products already in place.
- Because the individual staves of the panel continue to contract and expand, lines may appear on solid wood panels and offsets may develop from one stave to another. These stave lines will not be considered defective.
Note: To eliminate stave offsets, utilize the MDF center panel option.
- Veneer checking and seam separation are inherent characteristics of plywood panels that may appear to be cracks within the coating. These cracks are caused by changes within the veneer and will not be considered defective.
Note: To eliminate veneer checking, utilize the MDF center panel option.
- Customers interested in purchasing Prism Paint finishing materials through the DuraGuard Program should reference DuraGuard Systems information found in this section for coatings pricing and selection. It is strongly recommended that the DuraGuard paint be ordered at the same time as the finished parts to ensure an accurate color match.
- When purchasing multiple containers of loose Prism Paint coating material, mix the contents of like finishes together prior to adding catalyst to achieve a consistent overall color.
- Catalyst must be added to all Prism Paints prior to application. The catalyzation process results in both a limited pot life and a recoat window. Mixture and application instructions are provided near the end of this section.
- We recommend that any topcoat other than DuraGuard products be tested for compatibility prior to application. Conestoga will not warrant products that fail due to non-compatible topcoat materials.
- Conestoga assumes no responsibility for incorrect application of Prism Paint materials by customers, which may result in poor adhesion, color mismatch or other finish related failures.

Colourtones and Prism Paints with Hand Wiped Glazes

- Hand wiped glazed treatments offer a distinctive appearance, significantly altering the base Colourtone/Prism Paint colors. The random nature of the hand wiped glazing option ensures slight variations from one product to the next, giving a unique look to the finished kitchen.
- Each hand wiped glaze possesses specific characteristics that determine the appearance of the glaze on finished doors, drawer fronts and mouldings. Coffee and Pewter glazes are heavily pigmented glazes, creating a significant color change to the base Colourtone/Prism Paint. Profiled areas where these glazes are applied develop heavy lines that outline the profile. Chai and Oyster glazes are lighter in color and produce a more subtle color change to the base Colourtone/Prism Paint. They also produce much less of the highlighting effect in profiled areas.
- Since Cabinet Systems parts typically do not have profiled areas where glaze would hang, Cabinet Systems parts are not eligible to have a separate glaze applied.

Colourtones and Prism Paints with Hand Wiped Glazes (continued)

- Colourtones/Prism Paint parts receiving the hand wiped glazed option will have slight inconsistencies in appearance. Variations, however slight, are inherent to these finish combinations. To successfully market this product, education of your production personnel, installers, sales staff, designers and clients must take place.
- Characteristics of products finished with Colourtone/Prism Paints and hand wiped glazed finishes include variations in:
 - ♦ Glaze “hang” with noticeable variations on edge profiles, panel raises and applied mouldings.
 - ♦ Absorption into end grain on framing and panel raises.
 - ♦ Highlighting of machined areas which normally do not appear with typical wiping stains or base Colourtone/Prism Paint colors.
 - ♦ Appearance of blotchiness and rag marks.
- Components finished with Colourtones/Prism Paints and hand wiped glazes will remain within a controlled range of color; however, individual pieces will vary slightly.
- As with any Colourtone/Prism Paint product, we do not recommend ordering plywood panel doors or other veneered panel products due to the inherent cracking and checking that takes place with veneers. Veneer checking will not be considered a finishing defect.
Note: To eliminate veneer checking and cracking, utilize the MDF center panel option.
- Use of hand wiped glazes on mitered and applied moulding products will greatly enhance any offset that may be present in the joint construction.
- The machining of end grain on certain profiles may result in those surfaces being porous and the finish on these surfaces may not be as full as the finish on non-end grain areas. This matching will also cause the glaze to be heavier on these areas than non-end grain surfaces and are not considered to be defective.
- MDF doors finished with Colourtones/Prism Paints and hand wiped glazes will have noticeable variations in glaze hang and absorption on profiled areas. Machined areas may contain small pinholes that are highlighted by the glaze and will not be considered defects.

Customer Responsibilities

- All sample doors and swatches should be properly labeled with specie, finish color, date and sales order number.
- Sample doors and swatches should be stored in such a manner that they are not exposed to light or extreme heat for an extended period of time. Exposure to sunlight, indoor lighting or extreme heat will cause samples to discolor and they will no longer be an accurate representation of color. Sample swatches should be discarded and replaced when their expiration date is reached.
- **Sample doors and swatches should be replaced every 12 months or when they become discolored.** Cherry will need to be replaced more frequently than other species. Conestoga cannot guarantee that a current order will match a sample more than 12 months old. Jobs sold from a sample swatch older than one year will not be warranted for color match.
- We strongly recommend that a full kitchen **not be sold from a color swatch or fan deck.** Order a sample door to show a greater array of possible character effects on a particular color, design and specie combination.
- For displays that are older than one year or that may be discolored, we recommend that customers obtain a current sample door in that specie, finish and glaze combination. Remember, display kitchens do change color due to their exposure to natural light, indoor lighting, heat and other conditions. The change that takes place is very gradual and may be difficult to detect, especially if viewed daily.
- If a job is ordered based on the color of a sample door or display, make sure the sample is less than one year old and the color is accurate. Customers requesting replacements because the job does not match their sample will be asked to provide the original sample sales order number so the age of the sample may be determined. **Conestoga will not warrant products for color mismatch if the sample is more than 12 months old or is discolored due to excessive exposure.**

Prism Paint Fan Deck

- 1,600 eligible colors are showcased in this comprehensive fan deck.
- Divided into five sections: Colors, Neutrals, Whites & Pastel, Timeless and Historic.
- All paints are interior grade only, including the Historic Exterior Section.
- Each paint color is classified as either a Pastel, Deeptone or Bold. Each classification determines the Design Charge and material square foot cost when finishing is requested, or DuraGuard loose paints are selected.
- Refer to Conestoga's Customer Business Portal for a complete listing of paint colors and price categories.
- Prism Paints are available with Chai, Coffee, Oyster and Pewter glazes.
- Order Prism Paint fan decks using part #2602036A.

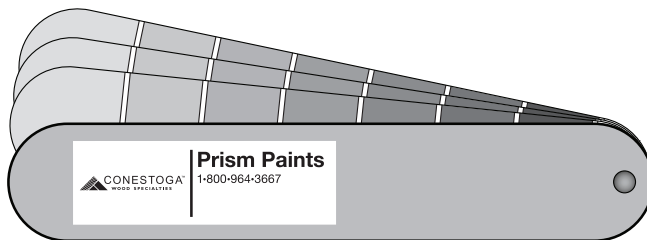

Advantage Finishing Options

Advantage Framed Cabinet Systems offers three finishing configurations for our cabinet parts - Exterior, Interior and Back - to give customers greater design flexibility. See diagrams below for listing of which pieces get finished with each configuration.

When completing the order forms, the finish specified on Advantage Cabinet Systems Order Form #7 will be considered the standard and applied to all three options when matching interior is ordered. To order a different finish for the Interior or Back of a cabinet with Matching Interior, note the area with the finish on Advantage Cabinet Systems Order Form #7-A in the Special Instructions area per cabinet. Order Forms are available on the Customer Business Portal and the Custom Product Manual.

Exterior Finishing

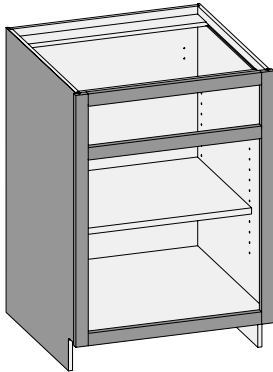

Includes:

- Front Frame – face, interior and exterior edges, finish only on exposed edge on back of front frame.
 - Exposed/flush sides – face only.
-

Interior Finishing (Only available with matching interiors)

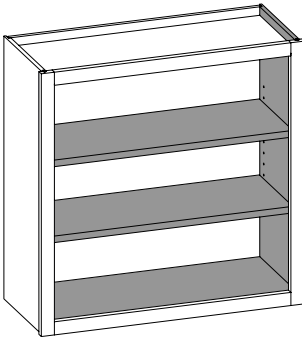

Includes:

- Sides – 1 interior face.
 - Top and Bottom – 1 interior face.
 - Fixed Intermediate Floor – 2 faces.
 - Shelves – 2 faces, edgebanded edges.
 - Any other matching interior components.
-

Back Finishing (Only available with matching interiors)

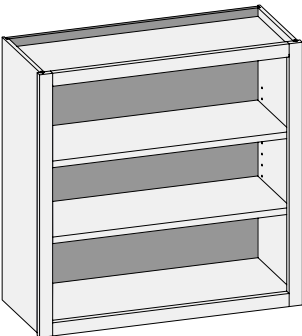

Includes:

- Backs – 1 interior face.

Vesta Finishing Options

Vesta Full Access Cabinet Systems offers three finishing configurations for our cabinet parts - Exposed Ends, entire Case and Edgeband only to give customers greater design flexibility. See diagrams below for listing of the areas finished with the selected configuration.

When completing the order forms, the finish specified on Vesta Cabinet Systems Order Form #8 will be considered the standard when Exposed Ends, Door Matching Edgeband or Matching Case Color is selected. Order Forms are available on the Customer Business Portal and the Custom Product Manual.

Matching Finished Edgeband

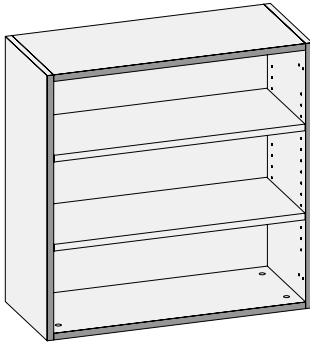

Includes:

- Edgeband on front edge of sides, tops, bottoms, mid-floors, stringers and all forward facing components.
 - Available in published plywood materials.
-

Finished Exposed End

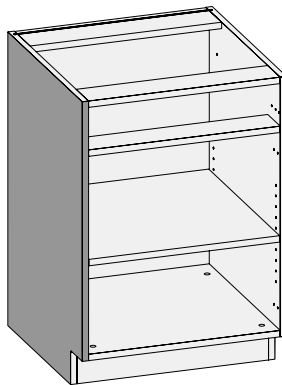

Includes:

- Sides only.
 - Available in Cherry, Hard Maple, Paint Grade and Red Oak with prefinished White Birch interior.
 - Not available in Walnut and Rift Cut with White Birch interior. Must order as Matching Case Color.
 - If PVC edgeband is selected, Finished Exposed Ends will be produced with matching finished edgeband.
-

Entire Case Finishing

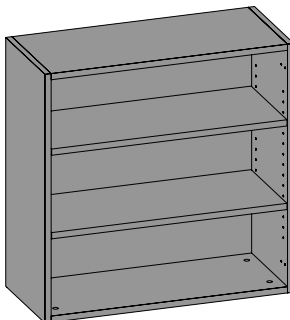

Includes:

- When Matching Case Color is selected in a plywood material, all cabinet parts are finished except for hanger cleats and toe backers.
- When Screw and Dowel construction method is selected, Exposed Ends must be identified to ensure pilot holes are removed from sides.

Offering and Availability

Colourtones on Cabinet Systems										
	Antique White	Arctic White	Cadet Grey	Crystal White	Designer White	Ebony*	Fern	Frosty White	Gunsmoke	Hearthstone Grey
Cherry										
No Glaze	NR	NR	R	NR	NR	R	R	NR	R	R
Chai	X	X	X	NR†	X	X	X	NR†	X	X
Coffee	X	X	X	NR†	X	X	X	NR†	X	X
Oyster	X	X	X	NR†	X	X	X	NR†	X	X
Pewter	X	X	X	NR†	NR†	X	X	NR†	X	X
Maple, Hard										
No Glaze	R	R	R	R	R	R	R	R	R	R
Chai	X	X	X	R†	X	X	X	R†	X	X
Coffee	X	X	X	R†	X	X	X	R†	X	X
Oyster	X	X	X	R†	X	X	X	R†	X	X
Pewter	X	X	X	R†	R†	X	X	R†	X	X
Maple, Soft (cabinet parts only)										
No Glaze	R	R	R	R	R	R	R	R	R	R
Chai	X	X	X	R†	X	X	X	R†	X	X
Coffee	X	X	X	R†	X	X	X	R†	X	X
Oyster	X	X	X	R†	X	X	X	R†	X	X
Pewter	X	X	X	R†	R†	X	X	R†	X	X
Paint Grade Hard Maple (doors only)										
No Glaze	R	R	R	R	R	R	R	R	R	R
Chai	X	X	X	R†	X	X	X	R†	X	X
Coffee	X	X	X	R†	X	X	X	R†	X	X
Oyster	X	X	X	R†	X	X	X	R†	X	X
Pewter	X	X	X	R†	R†	X	X	R†	X	X
Oak, Red										
No Glaze	R	R	R	R	R	R	R	R	R	R
Chai	X	X	X	X	X	X	X	X	X	X
Coffee	X	X	X	X	X	X	X	X	X	X
Oyster	X	X	X	X	X	X	X	X	X	X
Pewter	X	X	X	X	X	X	X	X	X	X

* Ebony Colourtones will magnify any small imperfection. Small imperfections such as dust or lint will not be considered defects.

† Doors, drawer fronts, mouldings and other Custom products will be finished with Colourtone and hand wiped glaze. Cabinet Systems case parts are not eligible to be finished with Colourtones/Prism Paints with glazes. Inset front frames are eligible to receive glazes.

Using Offering and Availability Charts

Offering and Availability Charts should be referenced prior to placing an order.

- Locate the desired finish in the top row, then follow the row down to the desired specie/glaze combination found along the left column of the chart.
- The box where the finish, specie and glaze combination intersects will contain one of the following references:

R = Recommended: These finish combinations refer only to the consistency of the finish application and not the aesthetic beauty of the combination.

NR = Not Recommended: These finish combinations are problematic and do not meet Conestoga's standards for color consistency. They also highlight various other characteristics such as machine marks and open end grain that will not be considered defective. NR combinations will receive a 20% upcharge to the Design Charge compensating for additional labor required for difficult combinations. Even if a sample door is purchased, we cannot guarantee that the next order will be an exact match to the sample door. Conestoga will not guarantee color consistency on NR combinations.

X = Not Available: Such combinations present application challenges which result in finish appearances Conestoga cannot consistently reproduce, and are not available.

Offering and Availability

Colourtones				
	Heron	Marina	Metropolitan Grey	Regent Blue
Cherry				
No Glaze	R	NR	R	NR
Chai	X	X	X	X
Coffee	X	X	X	X
Oyster	X	X	X	X
Pewter	X	X	X	X
Maple, Hard				
No Glaze	R	R	R	R
Chai	X	X	X	X
Coffee	X	X	X	X
Oyster	X	X	X	X
Pewter	X	X	X	X
Maple, Soft (cabinet parts only)				
No Glaze	R	R	R	R
Chai	X	X	X	X
Coffee	X	X	X	X
Oyster	X	X	X	X
Pewter	X	X	X	X
Paint Grade Hard Maple (doors only)				
No Glaze	R	R	R	R
Chai	X	X	X	X
Coffee	X	X	X	X
Oyster	X	X	X	X
Pewter	X	X	X	X
Oak, Red				
No Glaze	R	R	R	R
Chai	X	X	X	X
Coffee	X	X	X	X
Oyster	X	X	X	X
Pewter	X	X	X	X

	Standard Primer Only					
	White	Light Grey	Medium Grey	Dark Grey	Sage	Black
Cherry	R	R	R	R	R	R
Maple, Hard	R	R	R	R	R	R
Maple, Soft	R	R	R	R	R	R
Paint Grade Hard Maple	R	R	R	R	R	R
Oak, Red	R	R	R	R	R	R

R = Recommended: These finish combinations refer only to the consistency of the finish application and not the aesthetic beauty of the combination.

NR = Not Recommended: These finish combinations are problematic and do not meet Conestoga's standards for color consistency. They also highlight various other characteristics such as machine marks and open end grain that will not be considered defective. NR combinations will receive a 20% upcharge to the Design Charge compensating for additional labor required for difficult combinations. Even if a sample door is purchased, we cannot guarantee that the next order will be an exact match to the sample door. Conestoga will not guarantee color consistency on NR combinations.

X = Not Available: Such combinations present application challenges which result in finish appearances Conestoga cannot consistently reproduce, and are not available.

Offering and Availability

Wiping Stains									
	Alpine	Autumn	Bordeaux	Chestnut	Colonial	Cordovan	Dark Roast	Driftwood	Espresso
Cherry									
No Glaze	X	R	R	R	R	R	R	R	R
Brown	X	R	X	R	R	R	R	R	X
Caramel	X	R	X	R	R	R	R	R	X
Pewter	X	R	X	R	R	R	NR	R	X
Sable & Onyx	X	R	R	R	R	R	R	R	R
White	X	NR	X	X	X	X	X	R	X
Maple, Hard									
No Glaze	R	R	NR	NR	NR	NR	NR	R	NR
Brown	X	R	X	NR	NR	NR	NR	R	X
Caramel	X	R	X	NR	NR	NR	NR	R	X
Pewter	NR	R	X	NR	NR	NR	NR	R	X
Sable & Onyx	X	NR	NR	NR	NR	NR	NR	R	NR
White	R	R	X	X	X	X	X	R	X
Maple, Soft									
No Glaze	R	R	NR	NR	NR	NR	NR	R	NR
Brown	X	R	X	NR	NR	NR	NR	R	X
Caramel	X	R	X	NR	NR	NR	NR	R	X
Pewter	X	R	X	NR	NR	NR	NR	R	X
Sable & Onyx	X	NR	NR	NR	NR	NR	NR	R	NR
White	R	R	X	X	X	X	X	R	X
Oak, Red									
No Glaze	R	R	R	R	R	R	R	R	R
Brown	X	R	X	R	R	R	R	R	X
Caramel	X	R	X	R	R	R	R	R	X
Pewter	NR	R	X	R	R	R	NR	R	X
Sable & Onyx	X	R	R	R	R	R	R	R	R
White	R	R	X	X	X	X	X	R	X

R = Recommended: These finish combinations refer only to the consistency of the finish application and not the aesthetic beauty of the combination.

NR = Not Recommended: These finish combinations are problematic and do not meet Conestoga's standards for color consistency. They also highlight various other characteristics such as machine marks and open end grain that will not be considered defective. NR combinations will receive a 20% upcharge to the Design Charge compensating for additional labor required for difficult combinations. Even if a sample door is purchased, we cannot guarantee that the next order will be an exact match to the sample door. Conestoga will not guarantee color consistency on NR combinations.

X = Not Available: Such combinations present application challenges which result in finish appearances Conestoga cannot consistently reproduce, and are not available.

Offering and Availability

Wiping Stains										
	Ginger	Harvest Gold	Honey	Natural	Nickel	Nitefall	Nutmeg	Portabella	Saddle	Washington Cherry
Cherry										
No Glaze	R	R	R	R	R	R	R	R	R	R
Brown	R	R	R	R	R	X	R	R	R	R
Caramel	R	R	R	R	R	X	R	R	R	R
Pewter	R	R	R	R	R	X	NR	R	R	R
Sable & Onyx	R	R	R	R	X	R	X	R	R	R
White	NR	NR	X	NR	R	X	X	R	X	X
Maple, Hard										
No Glaze	R	R	NR	R	R	NR	R	NR	NR	NR
Brown	R	R	NR	R	R	X	R	NR	NR	NR
Caramel	R	R	NR	R	R	X	R	NR	NR	NR
Pewter	R	R	NR	R	R	X	NR	NR	NR	NR
Sable & Onyx	R	R	NR	X	X	NR	X	NR	NR	NR
White	R	R	X	R	R	X	R	R	X	X
Maple, Soft										
No Glaze	R	R	NR	R	R	NR	R	NR	NR	NR
Brown	R	R	NR	R	R	X	R	NR	NR	NR
Caramel	R	R	NR	R	R	X	R	NR	NR	NR
Pewter	R	R	NR	R	R	X	NR	NR	NR	NR
Sable & Onyx	R	R	NR	X	X	NR	X	NR	NR	NR
White	R	R	X	R	R	X	R	R	X	X
Oak, Red										
No Glaze	R	R	R	R	R	R	R	R	R	R
Brown	R	R	R	R	R	X	R	R	R	R
Caramel	R	R	R	R	R	X	R	R	R	R
Pewter	R	R	R	NR	R	X	NR	R	R	R
Sable & Onyx	R	R	R	R	X	R	X	R	R	R
White	R	R	X	R	R	X	R	R	X	X

Truetones					
	Ashen	Cocoa	Desert Sand	Seaside	Shale
Cherry					
No Glaze	R	R	R	R	R
Brown	R	R	R	R	R
Onyx	R	R	R	R	R
Oyster	R	R	R	R	R
Sable	R	R	R	R	R
Maple, Hard					
No Glaze	R	R	R	R	R
Brown	R	R	R	R	R
Onyx	R	R	R	R	R
Oyster	R	R	R	R	R
Sable	R	R	R	R	R

R = Recommended: These finish combinations refer only to the consistency of the finish application and not the aesthetic beauty of the combination.

NR = Not Recommended: These finish combinations are problematic and do not meet Conestoga's standards for color consistency. They also highlight various other characteristics such as machine marks and open end grain that will not be considered defective. NR combinations will receive a 20% upcharge to the Design Charge compensating for additional labor required for difficult combinations. Even if a sample door is purchased, we cannot guarantee that the next order will be an exact match to the sample door. Conestoga will not guarantee color consistency on NR combinations.

X = Not Available: Such combinations present application challenges which result in finish appearances Conestoga cannot consistently reproduce, and are not available.

Cabinet Systems Finishing Pricing

Design and Material Charges for Cabinet Systems Finishing

Finish Category	Design Charge	Material Charge per sq. ft.
Natural Finish		
Wiping stain, Low Complexity		
Wiping stain, High Complexity		
Truetones, Low Complexity		
Truetones, High Complexity		
Colourtones (on wood)		
Colourtones (on hybrid** & MDF) - doors only		
Primer - standard white (on wood)		
Primer – standard white (on hybrid** & MDF) - doors only		
Primer – standard light, medium, dark grey, black or sage (on wood)		
Primer – standard light, medium, dark grey, black or sage (on hybrid** & MDF) - doors only		
Prism Paints - Pastels (on wood)		
Prism Paints - Deeptones (on wood)		
Prism Paints - Bold (on wood)		
Prism Paints - Pastels (on hybrid** & MDF) - doors only		
Prism Paints - Deeptones (on hybrid**, MDF) - doors only		
Prism Paints - Bold (on hybrid** & MDF) - doors only		
Finish Options		
Hand wiped glazes (Doors only)		
Custom Wiping Stain Match (Initial match charge applies)		
Custom Wiping Stain	Low Complexity	
	High Complexity	
Finish Complexity/Color Selection		
Natural Finish	Clear sealer and topcoat	
Wiping Stains	Low Complexity	Autumn, Colonial, Ginger, Harvest Gold, Honey, Nutmeg, Portabella, Saddle, Washington Cherry
	High Complexity	Alpine, Bordeaux, Chestnut, Cordovan, Dark Roast, Driftwood, Espresso, Nickel, Nitefall
Truetones	Low Complexity	Desert Sand
	High Complexity	Ashen, Cocoa, Seaside, Shale
Colourtones	Antique White, Arctic White, Cadet Grey, Crystal White, Designer White, Ebony, Fern, Frosty White, Gunsmoke, Hearthstone Grey, Heron, Marina, Metropolitan Grey, Regent Blue	
Glazes (Stains)	Brown, Caramel, Onyx, Pewter, Sable, White	
Glazes (Colourtones)	Chai, Coffee, Oyster, Pewter	

* There will be a net surcharge for Pastel finishes, net surcharge for Deeptone finishes and a surcharge for Bold Prism Paint finishes on orders under 10 square feet.

**Hybrid door features MDF panel and solid wood framing.

Cabinet Systems Finishing Pricing

Ancillary Products Finishing Pricing		
Product	Design Charge multiplier	Material Charge
Front Frames	1 opening 2-3 openings 4-5 openings 6-7 openings 8+ openings	1x 1.5x 2x 2.5x 3x
		Front Frame Perimeter x 4 144 actual square footage (3 sq. ft. min.)
Plywood/Solid Wood Parts (sides, backs, shelves, tops, bottoms and toe boards)	1x	actual sq. footage ÷ 2
8 foot linear mouldings (face only)	1x	2 sq. ft.
8 foot linear mouldings (face and back)	2x	5 sq. ft.
Assembled mouldings	2x	5 sq. ft.
Valances, fillers, fluted fillers (finished on face and sides only)	1x	actual sq. footage
Plywood panels 1/8", 1/4", 3/4" (face only)**	1x	actual sq. footage ÷ 2

** 1/8" plywood panels only available finished on face only.

Range Hoods (See Custom Product Manual Section 11 for images and details)		
Batten Select, Select	3x	12 sq. ft.
Estate Canopy	6x	15 sq. ft.
Artisan, B, BX, CHW, E, E3, ER300, FX, FXBPUP, FX2HW, FX2PL, G, K300, P, T, VCHIM-SV, Z200 (45" or less in width)	6x	25 sq. ft.
Artisan, B, BX, CHW, E, E3, ER300, FX, FXBPUP, FX2HW, FX2PL, G, K300, P, T, VCHIM-SV, Z200 (45-1/16"+ in width)	8x	25 sq. ft.
AX3, BXB, CHWB, Farmhouse w/Chimney, GRA, I, Modern Tapered w/Chimney, TRA, VCHIM-AV, VCHIM-VRS, Waterfall (all sizes)	8x	25 sq. ft.
H2, M, S, SB100 (45" or less in width)	8x	25 sq. ft.
H2, M, S, SB100 (45-1/16" + in width)	11x	50 sq. ft.
SRA (all sizes)	11x	50 sq. ft.

Custom/Cabinet Systems Finish Offering

Finish and Specie Availability			
Finish Availability	Custom Front Frames	Cabinet Systems	End skins/Veneers
Stain/Stain & glaze/Truetones	yes	yes	yes
Colourtone finish w/no glaze	yes	yes	yes
Colourtone w/glaze	yes	no	yes
Primer only	yes	yes	yes
Wear sanding/Antiquing	no	no	no
Distressing level 1, 2 & 3	yes	yes	no
Specie Availability w/Colourtones	Custom Front Frames	Cabinet Systems	End skins/Veneers
Cherry	yes	yes	yes
Maple, Hard	yes	yes	yes
Maple, Soft	no*	yes	no
Oak, Red (w/Colourtones)	yes	yes	yes
Oak, Red (w/Colourtones & glazes)	yes	no	yes
Specie Availability w/Prism Paints	Custom Front Frames	Cabinet Systems	End skins/Veneers
Cherry, Maple, Hard, Maple, Soft, Oak, Red	yes	yes	yes

*Soft Maple front frames are not available in Colourtone or Prism Paint finishes on Cabinet Systems orders when the pre-fit or beaded option is selected.

Finish Sample Kits

Cherry	Hickory/Walnut	Maple, Hard	Oak	Colourtones
Stain/Glaze	Stain/Glaze	Stain/Glaze	Stain/Glaze	Colourtone/Glaze
Autumn Bordeaux Chestnut Colonial Cordovan Dark Roast Driftwood Driftwood/Brown Driftwood/Caramel Driftwood/Onyx Driftwood/Pewter Driftwood/Sable Driftwood/White Espresso Ginger Harvest Gold Honey Natural Nickel Nitefall Nutmeg Portabella Saddle Washington Cherry	Hickory Autumn Chestnut Dark Roast Driftwood Natural Portabella Portabella/Brown Portabella/Caramel Portabella/Onyx Portabella/Pewter Portabella/Sable Portabella/White Saddle Walnut Autumn Colonial Driftwood Espresso Ginger Harvest Gold Natural Nickel Nitefall Nutmeg Portabella Saddle	Alpine Autumn Autumn/Brown Autumn/Caramel Autumn/Onyx Autumn/Pewter Autumn/Sable Autumn/White Bordeaux Chestnut Colonial Cordovan Dark Roast Driftwood Espresso Ginger Harvest Gold Honey Natural Nickel Nitefall Nutmeg Portabella Saddle Washington Cherry	Oak, Red Autumn Chestnut Dark Roast Harvest Gold Honey Natural Nutmeg Saddle Oak, White Alpine Autumn Colonial Driftwood Espresso Ginger Natural Natural/Brown Natural/Caramel Natural/Onyx Natural/Pewter Natural/Sable Natural/White Nickel Nitefall Nutmeg Portabella	Cherry Crystal White/Antiqued Ebony/Antiqued Maple, Hard, Paint Grade Antique White Arctic White Cadet Grey Crystal White Designer White Ebony/Antiqued Fern Frosty White Frosty White/Chai Frosty White/Coffee Frosty White/Oyster Frosty White/Pewter Gunsmoke Hearthstone Grey Heron Marina Metropolitan Grey Regent Blue

Truetones
Stain/Glaze
Cherry
Ashen Cocoa Desert Sand Seaside Shale
Maple, Hard
Ashen Ashen/Brown Ashen/Onyx Ashen/Oyster Ashen/Sable Cocoa Desert Sand Seaside Shale
Oak, White
Ashen Cocoa Desert Sand Seaside Shale
Walnut
Ashen Cocoa Seaside Shale

Pricing per kit: Wiping stains (Cherry, Hard Maple, Hickory/Walnut and Oak) and Truetone kit: net. Colourtone kit: net.

Specifications: Swatch size: 4-1/4" x 6-1/8". Swatch has G-084 groove on face – except for finishes with Chai and Oyster glazes. Each swatch is individually labeled.

Kits are packed in a labeled file box, reducing the need to remove individual swatches for identification; this limits the exposure to light that accelerates color change.

Larger Swatch Size

Individual Recommended and Not Recommended finishes are available on 6-1/8" x 14" chips.

- Wiping stains and Truetones
- Colourtones
- Prism Paints Pastels
- Prism Paints Deeptones
- Prism Paints Bold

Conestoga DuraGuard System Overview

DuraGuard is a complete finishing material program designed to make it easy to match Conestoga's prefinished products, in which all the wiping stains, Truetones, Colourtones, Prism Paints, glazes, primers, sealers and topcoats work together to create a lasting finish on our customer's components.

- DuraGuard provides finishing materials, step-by-step instructions, access to our in-house finishing professionals and support products such as touch up kits.

DuraGuard System Features

- Access to all of Conestoga's topcoats, sealers, stains, paints, primers, glazes and other finishing related materials.
- Every shipment of finishing material includes a label with QR codes to provide step-by-step instructions detailing how to mix raw materials, sand the wood, apply the finish, and spray the topcoat.
- Access to our Finishing Department at (717) 445-3252 every business day, from 7:00 a.m. to 3:30 p.m. (EST). Our professionals are dedicated to answering any finishing questions our customers may have.
- Inexpensive touch up kits are available; these kits are used to hide scratches or blemishes incurred in our customers' shop. Touch up kits make a great gift for your satisfied customers. See DuraGuard Packaged Finish Pricing Chart in this section for details and pricing.

DuraGuard System Disclaimers

- Conestoga's finishes are industrial in nature, unlike finishes purchased at a retail store. Although they are of higher quality than most finishes, Conestoga's coatings are also more combustible, more volatile and require a greater level of expertise to apply.
- Due to the complexities involved with any finishing process, Conestoga will not be liable for any damages or injuries resulting from the use of this product, even if every precaution is taken by the customer. Conestoga's liability is limited to the original purchase price of the finishing material.
- In order to best match any DuraGuard finish color, it is important to follow the processes outlined in our instruction documents. These instructions are found in this section of the manual or by scanning the QR code on the DuraGuard label. If the proper steps are not followed, the finished product may not match the finished doors that were purchased from Conestoga. However, please bear in mind that following these procedures will not always guarantee an exact match.
- Due to the many variables involved in any finishing process, Conestoga assumes no responsibility if products finished by the customer using the DuraGuard System do not produce an exact match to prefinished products purchased from Conestoga.
- The DuraGuard Finishing System is scientifically designed so that each of the materials, from base coat to topcoat, work with one another, thereby providing a beautiful protective finish for our customer's products. Finishing products not sold by Conestoga may react unfavorably to the DuraGuard finishing materials causing poor topcoat adhesion, discoloration or other problems.

DuraGuard Packaged Finishes Pricing

Wiping Stains	Quarts	Gallons	5-Gallons	Primers (Catalyst V66V21 required)			
Alpine					Quarts	Gallons	5-Gallons
Autumn				White	NA		
Bordaeux				Black	NA		
Chestnut				Light Grey	NA		
Colonial				Medium Grey	NA		
Cordovan				Dark Grey	NA		
Dark Roast				Sage	NA		
Driftwood				Colourtones (Catalyst V66V21 required)			
Espresso				Antique White	NA		
Ginger				Arctic White	NA		
Harvest Gold				Cadet Grey	NA		
Honey				Crystal White	NA		
Nickel				Designer White	NA		
Nitefall				Ebony	NA		
Nutmeg				Fern	NA		
Portabella				Frosty White	NA		
Saddle				Gunsmoke	NA		
Washington Cherry				Hearthstone Grey	NA		
Truetone Stain				Heron	NA		
Desert Sand				Marina	NA		
Truetone Spray Stains (use w/ Truetone wiping stains)				Metropolitan Grey	NA		
Ashen	NA			Regent Blue	NA		
Cocoa	NA			Prism Paints (Catalyst V66V21 required)			
Seaside	NA			Pastels	NA		
Shale	NA			Deeptones	NA		
Truetone Wiping Stains (use w/ Truetone spray stains)				Bolds**	NA		
Ashen				Sealer & Topcoats (Catalyst V66V21 required)			
Cocoa				Sealer	NA		
Seaside				5° Topcoat	NA		
Shale				10° Topcoat	NA		
Glazes				30° Topcoat	NA		
Brown				General Catalyst			
Caramel				(use with primers, Colourtones, Prism Paint, Sealer & Topcoats)			
Chai				Catalyst V66V21			NA
Coffee				Cleaning Solvent			
Onyx				FT220 Lacquer Thinner	NA	NA	
Oyster				Touch Up Kits*			
Pewter				Wiping Stains, Truetones & Glaze Kits (net)			
Sable				Colourtones, Prism Paints & Custom Stain Kits (net)			
White				Colourtone Aerosol Can (net)			
				Clear Coat Aerosol Can - Low Sheen (net)			

Lead time for any single DuraGuard item including Stain, Colourtone, Glaze, Primer, Thinner, Catalyst, Topcoat or Sealer materials are as follows: 5 gallons or less - 3 business days. Can ship UPS or FedEx small package, Common Carrier or Conestoga Wood Transportation. 5-1/4 to 14-3/4 gallons - 5 business days. Can only ship Common Carrier or Conestoga Wood Transportation. 15 gallons or more - 8 business days. Can only ship Common Carrier or Conestoga Wood Transportation.

Custom stain match materials and Prism Paints are mixed on a per-order basis and cannot be expedited.

***Touch Up Kits:** Wiping stain, Truetone, Glaze and Colourtone kits include a stain marker and fil-stick. Prism Paint and Custom Stain kits include a marker and a vial of 10° sheen topcoat. Colourtone aerosol cans are 12 oz.

** Bold Prices include 1 gallon of Prism Paint and 2 gallons of tinted primer.

DuraGuard Finishing Instructions

All Wiping Stains (except Bordeaux, Dark Roast, Espresso, Nickel and Nitefall)

- Use this process to match all Conestoga wiping stains except Bordeaux, Dark Roast, Espresso Nickel and Nitefall stains.
- White wood sand with an oscillating palm sander using 180 grit sandpaper.
- Apply wiping stain over wood. Wipe all surfaces clean with lint-free rag.
- Allow wiping stain to dry for a minimum of 1 hour.
- Spray sealer to approximately 4 wet mil thickness.
- When the sealer is completely dry, sand sealer with fine grit (220-280) sandpaper using an oscillating palm sander on all flat surfaces. Hand sand all profiles with 220 grit sandpaper.
- Spray on topcoat to approximately 4 wet mil thickness.
- Allow topcoat to dry for a minimum of 4 hours before handling.

Bordeaux, Dark Roast, Espresso, Nickel and Nitefall Wiping Stains

- Use this process to match Conestoga's Bordeaux, Dark Roast, Espresso, Nickel and Nitefall wiping stains.
- White wood sand with an oscillating palm sander using 180 grit sandpaper.
- Moisten wood surface by lightly misting with water. Do not over saturate. Allow wood to completely dry for 30 to 60 minutes depending on relative humidity. This will open the grain allowing penetration of stain.
- Apply wiping stain over wood. Wipe all surfaces clean with a lint-free rag.
- Allow wiping stain to dry for a minimum of 1 hour.
- Spray sealer to approximately 4 wet mil thickness.
- When sealer is completely dry, sand sealer with fine grit (220-280) sandpaper using an oscillating palm sander on all flat surfaces. Hand sand all profiles with 220 grit sandpaper.
- Spray on topcoat to approximately 4 wet mil thickness.
- Allow topcoat to dry for a minimum of 4 hours before handling.

Hand Wiped Glazes Over Wiping Stains

- Use this process to apply hand wiped glazes over all Conestoga wiping stains.
- White wood sand with an oscillating palm sander using 180 grit sandpaper.
- Apply wiping stain over wood per DuraGuard finishing instructions. Wipe all surfaces clean with lint-free rag.
- Allow wiping stain to dry for a minimum of 1 hour.
- Spray sealer to approximately 4 wet mil thickness.
- When sealer is completely dry, hand sand all surfaces using 320 grit sandpaper. Make sure to sand in same direction as the wood grain.
- Apply the glaze to the entire surface and wipe the excess glaze off with a lint-free rag, leaving the desired amount of glaze in profiled areas. When matching existing products, make sure the same amount of glaze is left on the surface of the product being glazed as is on the product to be matched. Allow glaze to dry for 1 hour.
- Spray on topcoat to approximately 4 wet mil thickness.
- Allow topcoat to dry for a minimum of 4 hours before handling.

DuraGuard Finishing Instructions (continued)

Mixing Topcoats and Sealers

Follow this process when using DuraGuard topcoats and sealers to match products finished by Conestoga.

- Always use a lined can or plastic container when adding catalyst. Do not catalyze in an unlined metal can.
- Slowly pour the pre-measured container of catalyst into the gallon container of sealer or topcoat. Thoroughly agitate topcoat material, making sure there is no residue on the bottom of the can. Agitation must be continuous. **Do not over catalyze!**
- Once the catalyst has been added, the chemical interaction of the mixture results in a 24 hour “pot life”. After this 24 hour time frame, the mixture begins to cure rendering it unusable.
- Catalyst ratios are listed below.
- We strongly recommend against attempting to extend the pot life of sealer or topcoat by adding virgin material, as it will disrupt the catalyst ratio.
- Spray topcoat to a thickness of 4 wet mils.

Topcoat/Sealer	Amount of Catalyst
Conversion Varnish Products	
Sealer	4.0 ounces of catalyst V66V21 per gallon
10° (low sheen) topcoat	4.0 ounces of catalyst V66V21 per gallon
30° (medium sheen) topcoat	4.0 ounces of catalyst V66V21 per gallon

Topcoat Application Guidelines

- All standard hand wiped and Truetone stains default to 10° topcoat; 30° topcoat available upon request.
- All standard hand wiped and Truetone stains with glazes default to 10° topcoat; 30° topcoat available upon request.
- All Weathered Grain products finished with wiping stains, wiping stains with glazes, Colourtones and Colourtones with glaze default to 5° topcoat; 10° topcoat available upon request. 30° topcoat not available with Weathered Grain products.
- Antiquing, distressing and wear sanding options selected with wiping stains and wiping stains with glazes default to 10° topcoat; 30° topcoat is available upon request.
- Antiquing, distressing and wear sanding options added to Colourtone, Colourtone with glaze or Prism Paints default to 10° topcoat. 30° topcoat not available with any of these finish and option combinations.

DuraGuard Finishing Instructions (continued)

Truetones - Low Complexity

Use this process to match Conestoga's Low Complexity Truetone finishes.

- White wood sand with an oscillating palm sander using 180 grit sandpaper.
- Using spray equipment apply Truetone stain material over wood with even wet coats until the desired color is achieved. **(Diaphragm pump and HVLV gun recommended for spray application.)**
- Allow stain to dry for a minimum of 30 minutes.
- Spray sealer to approximately 4 wet mil thickness.
- When the sealer is completely dry, sand sealer with fine grit (220-280) sandpaper using an oscillating palm sander on all flat surfaces. Hand sand all profiles with 220 grit sandpaper.
- Spray on topcoat to approximately 4 wet mil thickness.
- Allow topcoat to dry for a minimum of 4 hours before handling.

Truetones - High Complexity

Use this process to match Conestoga's High Complexity Truetone finishes.

- White wood sand with an oscillating palm sander using 180 grit paper.
- Apply the Truetone wiping stain as the base color over wood. Wipe all surfaces clean with a lint-free rag.
- Allow Truetone wiping stain to dry for a minimum of 1 hour.
- Using spray equipment apply the matching Truetone spray stain material over the pre-stained wood with multiple light passes until uniform coverage is achieved. It may take as many as 4 to 6 light passes spraying in opposite directions to get uniform coverage on the board surface. **DO NOT** apply heavy wet coats as this may cause modeling and blotchiness in the spray stain. **(Diaphragm pump and HLVP gun recommended for spray application.)**
- Allow the spray stain to dry for a minimum of 30 minutes.
- Spray sealer to approximately 4 wet mil thickness.
- When the sealer is completely dry, sand sealer with fine grit (220-280) sandpaper using an oscillating palm sander on all flat surfaces. Hand sand all profiles with 220 grit paper.
- Spray topcoat to approximately 4 wet mil thickness.
- Allow topcoat to dry for a minimum of 4 hours before handling.

Hand Wiped Glazes Over Truetones

Use this process to apply hand wiped glazes over all Conestoga Truetones.

- Follow application instructions for desired Truetone finish.
- Allow Truetone to dry for a minimum of 30 minutes.
- Spray sealer to approximately 4 wet mil thickness.
- When sealer is completely dry, hand sand all surfaces using 320 grit sandpaper. Make sure to sand in same direction as the wood grain.
- Apply the hand wiped glaze to the entire surface and wipe the excess glaze off with a lint-free rag, leaving the desired amount of glaze in profiled areas. When matching existing products, make sure the same amount of glaze is left on the surface of the product being glazed as is on the product to be matched.
- Allow glaze to dry for a minimum of 1 hour.
- Spray on topcoat to approximately 4 wet mil thickness.
- Allow topcoat to dry for a minimum of 4 hours before handling.

DuraGuard Finishing Instructions (continued)

Colourtones and Prism Paints

Colourtones/Prism Paints are two-part, acid catalyzed, opaque basecoats, high in solids and similar to paint in appearance. Colourtone/Prism Paint finishing materials are non-catalyzed when purchased and must have catalyst purchased separately and added prior to application. These coatings are very durable and resistant to moisture.

Colourtones, Prism Paints and Catalyzation

Colourtone/Prism Paint finishing materials have superior film build, adhesion, excellent sanding properties and moisture resistance. It is extremely important to keep these materials thoroughly agitated while spraying. Coatings require the addition of an acid catalyst in order to cure. Since the catalyst has corrosive properties, neither the catalyst nor the catalyzed material should ever be stored in an unlined metal container. Thoroughly agitate material prior to the addition of catalyst. Add only the recommended ratio of catalyst and continue agitation for 5 minutes prior to spraying the material. **Do not over catalyze!** After catalyzation, material will have a maximum pot life of 24 hours.

Colourtone/Prism Paint materials have a limited amount of time between the application of the first and second coats and the application of topcoat. In order to achieve the proper chemical bond between coats, topcoat must be applied within 24 hours after applying the second coat. This time frame remains the same for both glazed and non-glazed products. The Colourtone/Prism Paint systems require a 10° conversion varnish topcoat. The use of any other topcoat material may result in lifting, discoloration, poor adhesion, cracking, poor moisture resistance and other finish related problems. Conestoga recommends the use of the DuraGuard glazes and topcoat in combination with Colourtone/Prism Paint finishing materials.

Surface Preparation for Colourtones and Prism Paints

- Fill all open voids with wood putty, sanding off excess putty.
- Sand surface of product with an oscillating palm sander using 180 grit sandpaper.

Spraying Colourtones and Prism Paints (Pastels and Deeptones)

- Thoroughly agitate Colourtone/Prism Paint material, add catalyst while material is under agitation. Add 4 ounces catalyst V66V21 to 1 gallon of Colourtone/Prism Paint in a lined metal can or plastic container. Pot life after catalyzation is 24 hours. Keep material under constant agitation.
- Spray Colourtone/Prism Paint material to a thickness of 4 wet mils.
- Allow first coat of material to dry for a minimum of 2 hours.
- Sand the entire surface with 280 grit sandpaper.
- Spray a second Colourtone/Prism Paint coat to a thickness of 4 wet mils.
- Allow the second coat to dry 2 hours before applying glaze or topcoat. A topcoat must be applied within 24 hours, whether product is glazed or non-glazed.
- Allow topcoat to dry for a minimum of 4 hours before handling.

Glaze over Colourtones

- Apply the glaze to all surfaces after the second coat of Colourtone is fully dry. Glaze may be applied with a rag and/or a brush.
- Wipe glaze off surfaces immediately using a “selective” wiping technique, leaving behind the desired amount of glaze in the profiled and flat areas. If matching to Conestoga prefinished products, ensure that the same amount of glaze is left in profiled areas and flat surfaces as on the Conestoga product.
- Allow glaze to dry for 1 hour.
- Spray with Conestoga’s DuraGuard 10° sheen conversion varnish topcoat to a thickness of 4 wet mils. A topcoat must be applied within 24 hours, whether product is glazed or non-glazed.
- Allow topcoat to dry for a minimum of 4 hours before handling.

DuraGuard Finishing Instructions (continued)

Bold Prism Paints

Conestoga's Bold Prism Paints differ from Pastel and Deeptone Prism Paints in that they require a specially tinted primer custom mixed per individual Bold Prism Paint color. In addition to the tinted primer material, a second coat of tinted primer must be applied prior to the Bold Prism Paint application. The result is a deep, consistent color that is durable and repeatable.

Surface Preparation for Tinted Primers

- Fill open voids with wood putty, sanding off excess putty.
- Sand surface of product with an oscillating palm sander using 180 grit sandpaper.

Spraying Tinted Primers for Bold Prism Paints

- Thoroughly agitate tinted primer material, ensuring there is no residue on the bottom of can. Add catalyst while the tinted primer is under agitation in a lined metal can or plastic container.
- Add 3 ounces of catalyst V66V21 to 1 gallon of tinted primer. Pot life after catalyzation is 24 hours. Keep material under constant agitation.
- Spray tinted primer to a thickness of 5 wet mils.
- Allow the first coat of tinted primer to dry for a minimum of 1 hour before sanding.
- When thoroughly dry, sand the entire surface with 280 grit sandpaper.
- Apply the second coat of tinted primer to a thickness of 5 wet mils.
- Allow second coat of tinted primer to dry for a minimum of 1 hour before sanding.
- When thoroughly dry, sand the entire surface with 280 grit sandpaper.

Spraying Bold Prism Paint

- Thoroughly agitate Bold Prism Paint material. Add catalyst while material is under agitation in a lined metal can or plastic container.
- Add 4 ounces catalyst V66V21 to 1 gallon of Bold Prism Paint. Pot life after catalyzation is 24 hours. Keep material under constant agitation.
- Spray Bold Prism Paint material to a thickness of 4 wet mils.
- Allow coat of Bold Prism Paint to dry from a minimum of 2 hours before applying glaze or topcoat. A topcoat must be applied within 24 hours, whether product is glazed or unglazed.
- Allow topcoat to dry for a minimum of 4 hours before handling.

DuraGuard Finishing Instructions (continued)

Topcoat over Colourtones and Prism Paints

- Thoroughly agitate topcoat material, ensuring there is no residue on bottom of can.
- Add 4 ounces of catalyst V66V21 per gallon of 10° sheen topcoat in a lined metal can or plastic container and agitate for 5 minutes prior to spraying. Keep topcoat under constant agitation. After catalyzation, the material has a 24 hour pot life. We do not recommend extending pot life by adding virgin material, as this will disrupt your catalyst ratio.
- Spray 4 wet mils of topcoat over Colourtone/Prism Paint.
- Allow topcoat to dry for a minimum of 4 hours before handling.

Antiquing on Colourtones and Prism Paints

Antiquing is a process to create the appearance that portions of the finish and even some of the substrate have been worn away from prolonged daily use.

- After allowing the Colourtone/Prism Paint material to thoroughly dry, the entire piece must be sanded with an oscillating palm sander using 280 grit sandpaper. Randomly sand through both coats of finish to expose the raw wood on profiled areas, edges and corners to simulate an aged, worn appearance. If antiquing is used in combination with the wear sanding option, follow the areas previously wear sanded. The amount and location of the antiquing should vary by personal preference, but should be focused on areas that would typically show wear from daily use. Refer frequently to the sample door finished by Conestoga.

Standard Primer Process

Conestoga's Standard primer is available in white, light grey, medium grey and dark grey and are post catalyzed, acid cured primers, compatible with many high quality topcoats. While there are many topcoats available on the market today, Conestoga recommends only acid cured, pigmented conversion varnishes.

Surface Preparation for Primer

- Fill all open voids with wood putty, sanding off excess putty.
- Sand surface of product with an oscillating palm sander using 180 grit sandpaper.

Spraying Standard Primer

- Thoroughly agitate primer materials, ensuring there is no residue on bottom of can. Add catalyst while the primer is under agitation in a lined metal can or plastic container.
- Add 3 ounces catalyst V66V21 to 1 gallon of primer. Pot life after catalyzation is 24 hours. Keep material under constant agitation.
- Spray primer to a thickness of 5 wet mils.
- Allow primer to dry for a minimum of 1 hour before sanding.
- Sealer sand the entire surface with 280 grit sandpaper prior to applying a color coat.

Colourtone Touch Up Aerosol

- This aerosol can is for minor touch up only and is not formulated to be used as a Colourtone paint substitute. Light scuff sanding of the defective area with a 320 grit sponge is recommended prior to spray application for increased adhesion. This product is not a final topcoat and must receive a coat of clear surface repair lacquer to match sheen and ensure durability.
- Surface Preparation: Surface should be clean and dry. Remove dirt, grease, oil, wax and loose paint.
- For instructions on the use of touch up aerosol, see directions printed on can label: use outdoors or in a well ventilated area when temperature is between 68° to 78°F (20° to 26°C) and humidity is below 60% to ensure proper drying. Mask surrounding area where over spray might settle. Shake can for at least one minute, listening for rattle of mixing ball. Shake for 10 seconds at 1-2 minute intervals during application. Hold can 6 to 10 inches from surface. Press spray button firmly. Do not cover with continuous spray. Move back and forth releasing spray head after each stroke. Overlap each stroke. Apply two thin coats rather than one heavy coat.
- Clean up: If spray button becomes clogged, pull off and clean with solvent.

DuraGuard Finishing Instructions (continued)

Legal Disclaimers

- DuraGuard finishes are industrial in nature, unlike finishes purchased at a retail store. Although DuraGuard offers a higher quality finish than most finishes, it also is more combustible, more volatile and requires a higher level of expertise to apply. Due to the complexities involved with any finishing process, Conestoga will not be liable for any damages or injury resulting from the use of this product, even when the customer has taken precautions. Conestoga's liability is limited to the original purchase price of the finishing material.
- In order to best match any DuraGuard finish color, it is important to follow the processes outlined on the previous pages. If these steps are not followed, your finished product may not match the products purchased from Conestoga. However, please bear in mind that following these procedures will not always guarantee an exact match. Due to the many variables involved in any finishing process, Conestoga assumes no responsibility if products that are finished by the customer using the DuraGuard System are not an exact match to the finished products sold by Conestoga.

Important Note: All drying times mentioned in this document are to be used as guidelines only. The actual drying time will vary according to the climate in which the finish is applied.

- The DuraGuard Finish System is scientifically designed so that each of the materials, from basecoat or stain, to topcoat, work with one another, thereby providing a beautiful protective finish for your wood products. Finish materials not sold by Conestoga may react unfavorably with DuraGuard finishing materials causing poor topcoat adhesion, discoloration or other problems.
- Color variation can occur on separately ordered jobs. Conestoga cannot guarantee color matches on material ordered at different times. Length of time between orders may also be a factor affecting color variation. Environmental factors where existing material is stored or installed may affect finished products to the degree of causing an appearance different to that of a newly finished product. To better ensure consistency of appearance, Conestoga recommends against placing partial orders.

Health and Safety Information

Refer to SDS for health and safety information. Log on to www.conestogawood.com/sds for 24 hour access to SDS information.

Care and Cleaning of Fine Kitchen Cabinetry

- The DuraGuard topcoat offers the utmost protection for kitchen cabinet applications and provides superior chemical and common kitchen stain resistance while maintaining color and sheen.
- DuraGuard topcoats require minimal care and cleaning. We recommend periodic cleaning with a mild detergent and water solution to remove dirt, dust and grease that buildup with routine usage. Dampen a soft, non-abrasive cloth and wipe entire exterior surface of cabinetry and dry with a soft cloth. Never use a wet cloth that allows water to run down the cabinetry and always dry cabinetry immediately if water is spilled onto the surface.
- Care should be taken not to use abrasive cleansers, ammonia or any other type of harsh chemical. These cleaning agents may cause discoloration, scratching, marring and dulling of the finish. We also discourage use of furniture polishes and waxes on finished cabinetry. Furniture polishes alter the original sheen level and may leave a film on the surface that attracts dust and dirt. These polishes may also cause an irregular or blotchy appearance because they are unable to stand up to many common kitchen stains.

Customer Supplied Parts for Finishing		
Customer Name:	Page: of	Order Date:
Ship To:	Customer #:	
	PO #:	
	Shipping Instructions:	
Attention:		
Phone #:		
Description of part to be finished:		
Quantity:	Size: Length _____ Width _____ Height _____	
Specie:	Options:	
<input type="checkbox"/> Stain color _____	<input type="checkbox"/> Photo included <input type="checkbox"/> Drawing Included	
<input type="checkbox"/> Colourtone color _____	Manufacturer:	
<input type="checkbox"/> Glaze color _____	Manufacturer's part number:	
Topcoat Gloss <input type="checkbox"/> 10° <input type="checkbox"/> 30°		
Special Instructions/Sketch:		
<p>Disclaimer I verify that I have read, understand and agree to the terms and conditions on finishing parts supplied by customer on page 8.35 of the Custom Product Manual. Customer supplied parts being sent to Conestoga cannot be transported on Conestoga trucks.</p>		
Signature _____		Date _____
Failure to sign and return this document could delay the processing of your quote.		

Customer Wiping Stain Match		
Customer Name :	Page: of	Order Date:
Ship To:	Customer#:	
	PO#:	
	Shipping Instructions:	
Attention :		
Phone #:		
Specie:	Grade:	
Stain Color:	Glaze Color:	
Sheen: <input type="checkbox"/> 10° (standard) <input type="checkbox"/> 30°		
RMA#:		
Special Instructions:		
<p>Disclaimer I verify that I have read, understand and agree to the guidelines of wiping stain match by customer on pages 8.2-8.3 of the Custom Product Manual. Customer supplied wiping stain match being sent to Conestoga cannot be transported on Conestoga trucks.</p>		
Submitted by: _____		Date: _____
<p style="text-align: center;">Failure to sign and return this document could delay the processing of your quote.</p>		

Conestoga Material Pricing Guide

Effective July 21, 2025
All prices are per square foot.

Species (Standard grade unless otherwise noted)	Material Category			Availability	
	A	B	C	Premium Grade	1" Thick
Alder					
Alder, Rustic Knotty					
Bamboo (Caramelized)					
Birch, Red					
Birch, White					
Cherry					
Cherry, Rustic Knotty					
Hickory					
Hickory, Rustic Knotty					
Maple, Hard					
Maple, Hard, Rustic Knotty					
Maple, Soft					
MDF 1-Piece					
MDF 1-Piece w/1SGP					
MDF 5-Piece					
Oak, Red					
Oak, Red, Rift Cut					
Oak, Red, Rustic Knotty					
Oak, White					
Oak, White, Quarter Sawn					
Oak, White, Rift Cut					
Paint Grade					
Paint Grade Hybrid**					
Paint Grade Hard Maple					
Paint Grade Hard Maple Hybrid**					
Pine, Knotty*					
Walnut					

A = Available **NA = Not Available**

For complete list of Advantage Component Specie Availability see table in Section 5 on page 5.3.

For complete list of Vesta Component Specie Availability see table in Section 13 on page 13.4.

Premium Grade Upcharge Add 35% to Standard grade price. Veneer doors ordered in Premium grade will receive Premium framing and Standard grade panel.

Frame Only Glass Doors Refer to "Frame-Only" page 6.1 in the Custom Product Manual for Accent Doors and Panels for pricing instructions.

Cabinet pricing available through Con-Nex or by requesting a quote.

*Knotty Pine crown and trim mouldings will be manufactured using Clear White Pine materials. If Clear White Pine doors, drawer fronts and front frames are desired signify Premium grade upgrade.

**Hybrid Products – Defined as solid wood framing with MDF panels. Hybrid Products are recommended when using opaque finishes such as Colourtones, primers and Prism Paints to avoid stave lines and veneer checking after finish is applied.

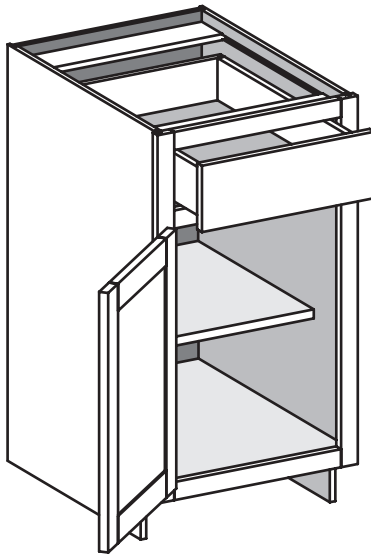
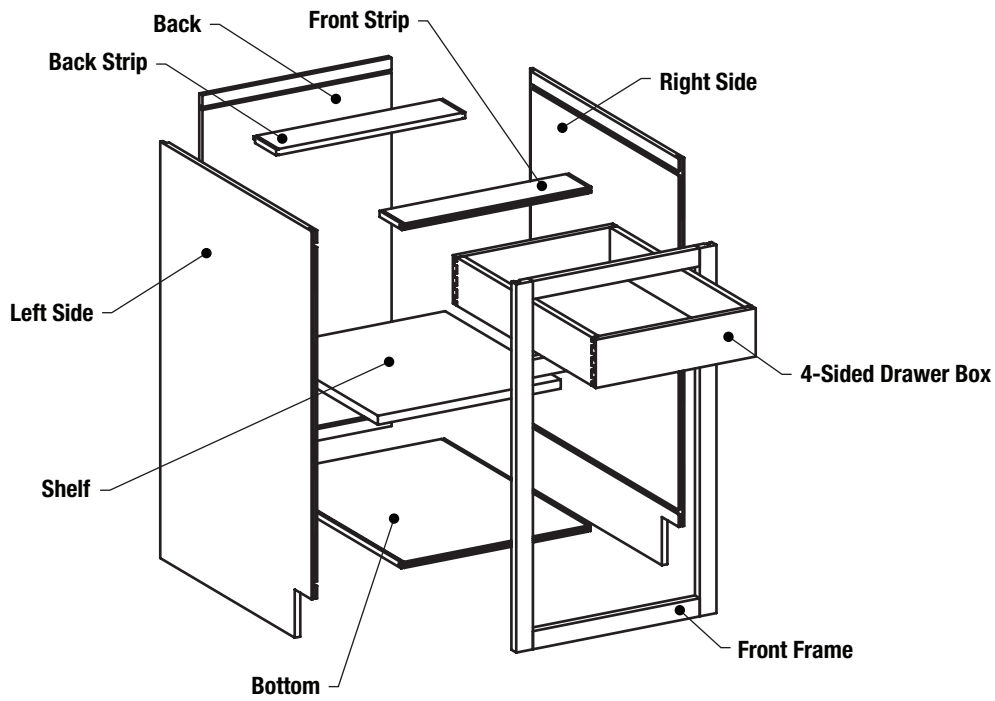

Advantage Design and Assembly

Conestoga's precut and machined Framed Cabinet Systems units are designed to assemble quickly and easily. Tools required include a rubber mallet, Phillips Head Screwdriver, and a pin gun (1/2" and 1-1/4" pins).

- Tops and bottoms slide into dovetailed grooves on the cabinet sides. Two 3" wide strips are used for the top of Base cabinets. The back lays into rabbets on the cabinet sides and is secured with glue and pins/staples.
- Sides have pre-inserted splines which easily engage and lock cabinet sides to the front frame. A series of splines are pre-inserted into cabinet tops, bottoms and mid-floors to secure these components to the front frame while adhesives dry.
- 1/2" thick cabinet backs provide a secure surface area for installation screws. Backs are inset 1/4" in from the back edge of cabinet sides to account for irregularities in wall surfaces.
- **Reference assembly instructions** which are available by selecting the box on the order form or downloading from the CBP.

All Plywood Construction

- **Front Frames:** 3/4" thick solid wood with 1-1/2" wide stiles and rails unless otherwise specified. Blind mortise and tenon joints. Non-standard configurations must be ordered as custom front frames.
- **Cabinet Sides:** 1/2" thick plywood with prefinished White Birch veneer on the interior face.
- **Cabinet Tops:** 1/2" thick plywood with prefinished White Birch veneer on the interior face. Most Base cabinets have open tops with two 1/2" thick x 3" deep plywood support strips running across the full width of the cabinet in the front and back. Base Sink and Vanity Sink cabinets include cut-back support strips that run front to back to ease sink installation. Some Specialty cabinets have full tops.
- **Cabinet Bottoms:** 1/2" thick plywood with prefinished White Birch veneer on the interior face.
- **Cabinet Backs:** 1/2" thick plywood with prefinished White Birch veneer on the interior face.
- **Shelves:** 3/4" thick White Birch plywood with a banded front edge. Both sides of White Birch plywood shelves are finished with a UV topcoat. Shelf height is adjustable in 32mm increments. Plywood shelves are standard and can be upgraded to a solid Natural Birch wood shelf on most cabinets.
- **Drawer Boxes:** English dovetail construction. 5/8" thick solid wood with eased top edge. 1/4" thick bottoms are standard; 3/8" thick bottoms with additional drawer box options are available. Drawer boxes are finished with a durable UV topcoat. Natural Birch is standard, Hard Maple and Walnut upgrades are available.
- **Toeboard Backers:** 1/2" thick plywood with prefinished White Birch veneer on both sides. Designed to fully enclose toe space and provide support for applied finished toeboards.
- **Toeboard Strips:** Available in 4" high x 8' long x 1/2" thick plywood strips in Cherry, Hard Maple or Red Oak.
- **Prefinished Interior:** Clear UV topcoat on interiors is standard. The UV topcoat is on the interior of the backs, tops, bottoms and sides. If you wish to finish the interior cabinet surfaces order Matching Specie Interior Option.
- **Matching Specie Interior:** Matching Specie Interior cabinets are unfinished. Drawer box parts and solid wood shelf upgrades are not available with Matching Specie Interior and will be finished with a durable UV topcoat.

Specie	Advantage Component Specie Availability											
	Cabinet Case Species	Doors/Drawer Fronts	Front Frame	Matching Interior	Flush Ends	Exposed Ends	Door End Panel	Mouldings	1/4" Cut-to-Size Plywood	1/2" Cut-to-Size Plywood	3/4" Cut-to-Size Plywood	Wood Edgeband
Alder	No	Yes	Yes	No	No	No	Yes	Yes	Yes	No	No	Yes
Bamboo	No	Yes	Yes	No	No	No	Yes	Yes	Yes	No	Yes	Yes
Birch, Red	No	Yes	Yes	No	No	No	Yes	Yes	Yes	No	No	No
Birch, White	No	Yes*	Yes*	No	No	No	Yes*	Yes	Yes	No	No	Yes
Cherry	Yes	Yes*	Yes*	Yes	Yes	Yes	Yes*	Yes	Yes	Yes	Yes	Yes
Hickory	No	Yes*	Yes*	No	No	No	Yes*	Yes	Yes	No	No	Yes
Mahogany	No	Yes	Yes	No	No	No	Yes	Yes	Yes	No	No	No
Maple, Hard	Yes	Yes*	Yes*	Yes	Yes	Yes	Yes*	Yes	Yes	Yes	Yes	Yes
Maple, Soft	Yes	Yes	Yes	Yes**	Yes**	Yes**	Yes	Yes	Yes**	Yes**	Yes**	Yes**
Oak, Red	Yes	Yes*	Yes*	Yes	Yes	Yes	Yes*	Yes	Yes	Yes	Yes	Yes
Oak, Red, Rift Cut	No	Yes	Yes	No	No	No	Yes	No	Yes	No	Yes	No
Oak, White	No	Yes*	Yes*	No	No	No	Yes*	Yes	Yes	No	No	Yes
Oak, White, Quarter Sawn	No	Yes	Yes	No	No	No	Yes	No	Yes	No	No	No
Oak, White, Rift Cut	No	Yes	Yes	No	No	No	Yes	No	Yes	No	Yes	No
Paint Grade	No	Yes	Yes	Yes**	Yes**	Yes**	Yes	No	No	No	No	No
Paint Grade Hard Maple	No	Yes	Yes	Yes**	Yes**	Yes**	Yes	Yes	Yes**	No	No	No
Pine, Clear	No	Yes*	Yes*	No	No	No	Yes*	Yes	No	No	No	No
Pine, Knotty	No	Yes	Yes	No	No	No	Yes	No	Yes	No	No	No
MDF	No	Yes	No	No	No	No	Yes	No	Yes	Yes	Yes	No
Walnut	No	Yes*	Yes*	No	No	No	Yes*	Yes	Yes	No	Yes	Yes

Standard plywood case has a White Birch interior with UV topcoat and an unfinished Natural Birch exterior. For specie modification, select from Matching Interior (MI), Exposed End (EXP) or Flush End (FL) options.

*Specie is also available in Premium grade for doors and drawer fronts only. Material upcharge applies.

**When Paint Grade, Paint Grade Hard Maple or Soft Maple is ordered, plywood components are produced using Hard Maple plywood. Solid wood components are produced using Paint Grade, Paint Gade Hard Maple or Soft Maple.

Door Overlays

Advantage Framed Cabinetry offers four standard overlays and inset doors. Standard overlays include 1/4", 1/2", 1-1/4" and 1-3/8". When you select either 1-1/4" or 1-3/8" overlays, Extended Stiles or Loose Filler Strips may be required for applications where cabinets are installed adjacent to a wall or Tall cabinet to ensure adequate clearance. The need for Extended Stiles or Loose Filler Strips is dependent on the type of hinge used. Corner cabinets include special hinges.

The following page includes diagrams illustrating the various overlays, the spacing between doors, and distance from the door's edge to the outer edge of the front frame.

Note: Butt Door Cabinets have 1/8" spacing between doors and drawer fronts regardless of the selected overlay.

Overlay Diagrams (w/center stile)

1/4" Overlay

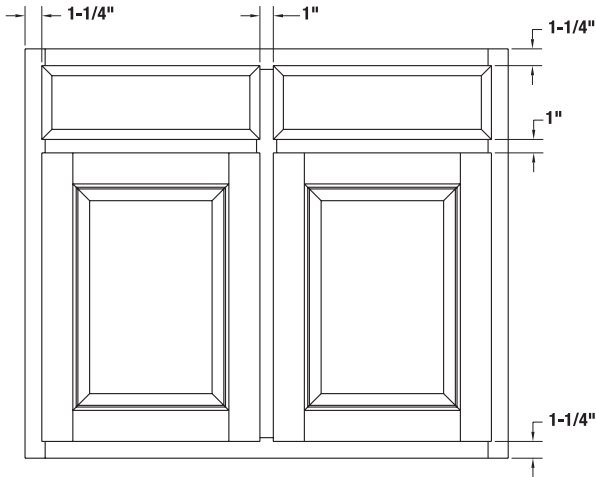
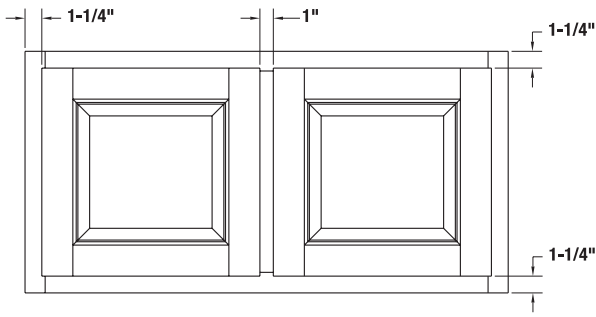

1/2" Overlay

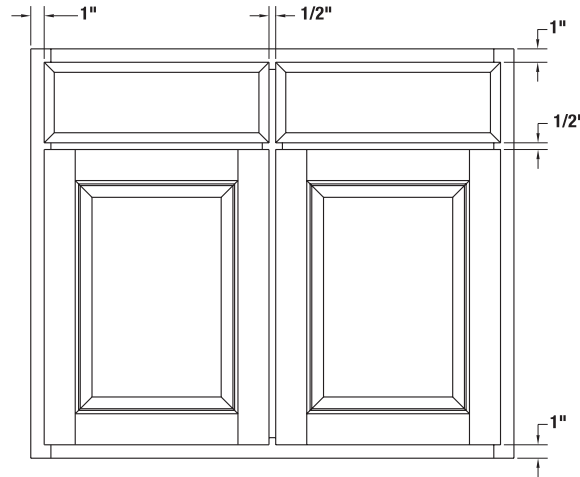
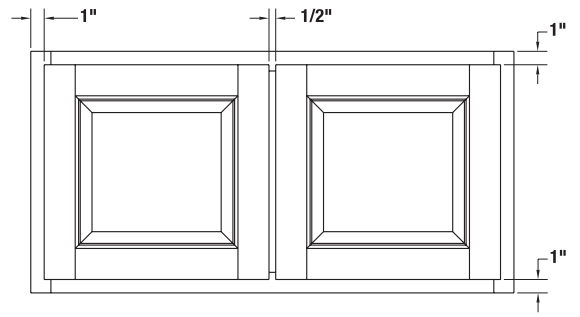

1-1/4" Overlay

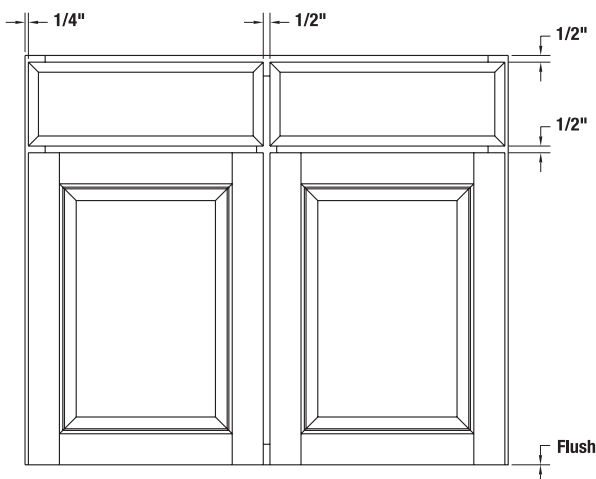
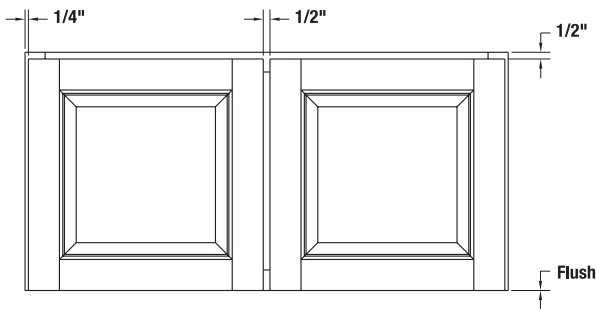

1-3/8" Overlay

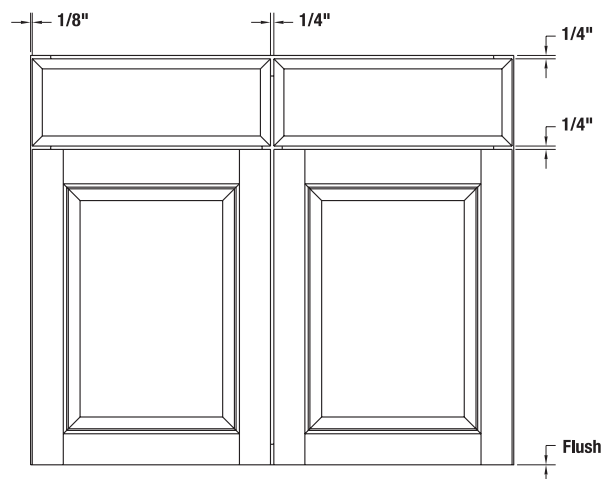
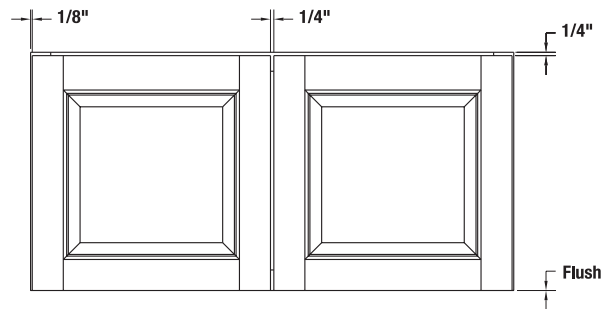

Advantage Inset Door and Drawer Information

- Front frames ordered with inset doors and drawer fronts will be pre-fit to the cabinet opening size. A 3/32" margin will be used on all sides for single doors and drawer fronts, and between butt door pairs.
- The following edge profile options are recommended for use with inset doors and drawer fronts. These edges have a 5° back bevel edge to ensure sufficient door clearance. Machine Edge is available upon request with no upcharge.

Standard Edge Profile Options



L-253



L-686

Design Exceptions

- The following door and drawer front designs are not available for inset applications due to their unique design characteristics: 1-1/8" Sandwiched Drawer Front, #10 Drawer Front, 10141 Drawer Front, Alexandra, Aspen, AspenPP, Astoria, Boulder, BoulderPP, CRP-1420, CRP-10191, CRP-10318, CRP-10334, CRP-10827, CRP-10875, CRP-10946, Fairhaven, Fargo, FargoPP, Flush Batten, Hastings, Juno, Keystone Drawer Front, LaSalle, Marcel Drawer Front, Omaha, OmahaPP, Prestige, Rothbury, Rothsford, Savoy, Topeka, TopekPP, TW-10827, Venus, Venus78, and Woodhull.
- Alexandra, Juno, Venus and Venus78 door and drawer front designs are available for inset applications only when ordered with Machine Edge or L-253 edge profiles.
- Alternative Material doors and drawer fronts are unavailable for inset applications including Allure DLV, Intrigue TTS, Strata TTS, Vogue TTS, Synchronicity High Gloss and Super Matte products.
- L-253 and L-686 are standard edge profile options for inset applications. Premium edge profiles L-304 and L-996 are available, an upcharge applies.
- Front frame openings with trimmable inserts are not available beaded.
- Inset and beaded front frames ordered with Colourtones and glazes will receive the same hand glazed finishes on doors, drawer fronts and mouldings.

Inset Door and Drawer Information (continued)

Inset Option with Miter Designs - Not Recommended

Only miter door designs with edge profile options are available with the inset option; however, miter designs are not recommended with the inset option. The following issues are associated with inset miter designs, and **will not be considered defective if chosen**:

- Miter joints may not intersect with the door corner after pre-fit sanding. This is not considered a defect as it is a necessary part of the pre-fit process to ensure the proper fit within the frame openings. This condition may not be pleasing to some customers.
- Panel expansion caused by high humidity conditions may cause miter doors to bind inside frame openings. Although Conestoga's miter door joint construction is one of the most durable in the industry, high humidity will cause solid wood center panels to expand in width. This pressure can result in the framing pushing outward and creating a "barrel" effect where the framing rubs against the front frame.
- If a miter design is selected, it is highly recommended that doors and drawer fronts be manufactured as 5-piece MDF, Hybrid products or products with plywood center panels. These materials will reduce the likelihood of product expansion and binding of inset doors within the front frame. While reducing the possibility of binding, expansion of solid wood framing can still occur and will not be considered defective.

Inset Door Diagram (w/center stile)

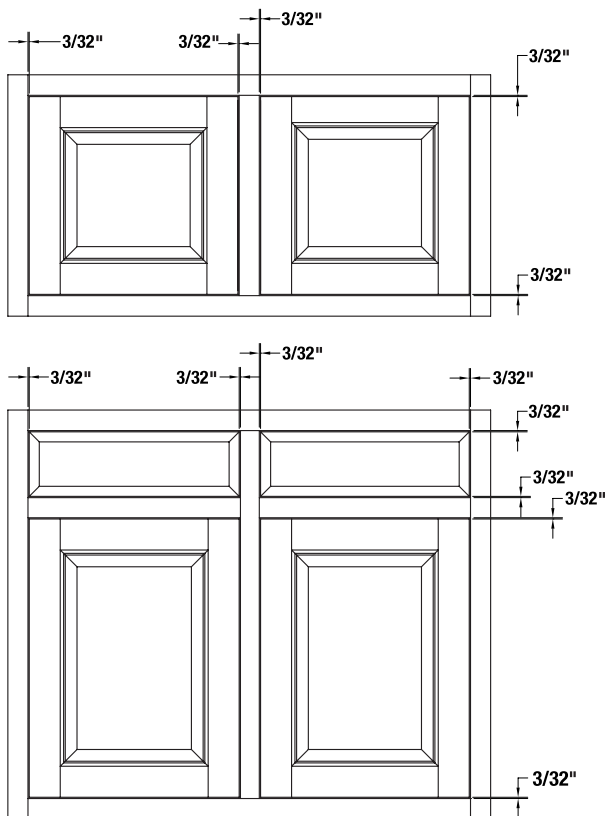

Advantage Wall Cabinet Standard Features and Options

The information described below are some of the features and options of the Advantage Wall cabinets. Customers have the option to omit these standard features as well as add other design options, which can be quickly referenced at the bottom of each page in the Wall Cabinet Section labeled “Wall Options Key”. For more detailed descriptions and images of all available options see Options, Section 12 within this manual. The options described below are available on all Wall cabinets unless specifically noted next to the individual cabinet as **Unavailable Options**.

Standard Shelving & Omit Shelving (OS) – 3/4” thick White Birch plywood shelving with a durable UV topcoat is standard with any Wall cabinet with shelves. If shelving is not desired within a specific cabinet, indicate **Omit Shelving Option** when ordering.

5mm Shelf Holes & No Shelf Holes (NSH) – Pre-drilled 5mm shelf holes on 32mm centers are a standard feature of all Wall cabinets with shelves. If shelf holes are not desired, indicate **No Shelf Holes Option** when ordering. **Note:** If shelving and shelf holes are not desired, both No Shelf Holes and Omit Shelving must be specified when ordering.

Cabinet Case Material Options – Most optional cabinet case materials will match the door, drawer front and face frame specie and are available with Wall cabinets produced in standard Advantage species.

- **Exposed Ends (EXP)** – Matching specie veneer on the exterior face of 1/2” thick plywood cabinet sides. The interior of plywood Exposed Ends will remain as White Birch.
- **Flush Ends (FL)** – Matching specie veneer on the exterior face of 3/4” thick plywood cabinet flush sides. The interior of plywood Flush Ends will remain as White Birch.
- **Flush Unexposed Ends (FUE)** – Non-matching specie veneer on the exterior face of the 3/4” thick flush plywood cabinet sides. Designed to be utilized when extra support is desired from non-exposed flush end panels. The interior of the plywood Flush Unexposed Ends will remain as White Birch.
- **Matching Interior (MI)** – Matching specie veneer is available on all internal cabinet parts. The Matching Interior Option is not available in combination with the Solid Wood Shelf Upgrade Option.

Solid Wood Shelf Upgrade (WS) – The **Solid Wood Shelf Upgrade Option** replaces the standard White Birch prefinished plywood shelving with solid Natural Birch shelving. The Solid Wood Shelving is 3/4” thick with a bullnosed front edge and finished with a UV topcoat. The Solid Wood Shelf Upgrade Option is not available in combination with the Matching Interior Option or when Wall cabinets are deeper than 24”. Solid shelving available up to 18” deep.

Natural Finished Bottom (NB) – The **Natural Finished Bottom Option** provides a UV topcoat on the exterior of the top and bottom of the Wall cabinet. When the Natural Finished Bottom Option is selected, cabinet top and bottom exteriors will be upgraded to a White Birch plywood.

Extended Stiles (EXT) – The **Extended Stile Option** provides additional width on the left, right or both stiles of the front frame. This additional material provides clearance between the cabinet and adjacent walls or other cabinetry allowing cabinet doors and drawers to fully open without interference. Extended stiles also provide the opportunity to scribe the frame to the wall contours during the installation process.

Prep for False Door Side (PFD) – The **Prep for False Door Side Option** maintains the overall front frame width ordered, but relocates the cabinet side panel, moving it inward by 13/16” for each Prep for False Door Side ordered. This creates a 3/4” reveal behind the 1-1/2” front frame stile to accommodate the decorative door end panel. The Prep for False Door Side Option can be ordered for the left, right or both cabinet sides. All cabinet components are automatically resized accordingly when the Prep for False Door Side Option is selected.

W/CSW - Wall Cabinet

Custom Size Ranges
 Single Door Width: 9" – 24"
 Butt Door Width: 24" – 36"
 Height: 12" – 72"
 Depth: 5-1/2" – 27"

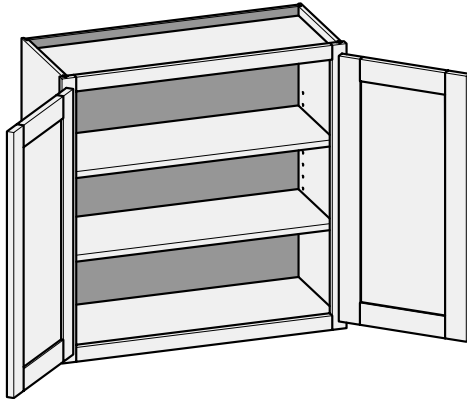

- 12" – 18" high has no shelves.
- 18-1/16" – 24" high has one shelf.
- 24-1/16" – 36" high has two shelves.
- 36-1/16" – 48" high has three shelves.
- 48-1/16" – 60" high has four shelves.
- 60-1/16" – 72" high has five shelves.
- Specify single or butt doors on custom size cabinets 24" wide.

Single Door Cabinet - 12 -1/2" Deep		
30" High	36" High	42" High
W0930	W0936	W0942
W1230	W1236	W1242
W1530	W1536	W1542
W1830	W1836	W1842
W2130	W2136	W2142
W2430	W2436	W2442

Butt Door Cabinets - 12-1/2" Deep

12" High	15" High	18" High	21" High	24" High	27" High	30" High	36" High	42" High
W2412BD	W2415BD	W2418BD	W2421BD	W2424BD	W2427BD	W2430BD	W2436BD	W2442BD
W2712BD	W2715BD	W2718BD	W2721BD	W2724BD	W2727BD	W2730BD	W2736BD	W2742BD
W3012BD	W3015BD	W3018BD	W3021BD	W3024BD	W3027BD	W3030BD	W3036BD	W3042BD
W3312BD	W3315BD	W3318BD	W3321BD	W3324BD	W3327BD	W3330BD	W3336BD	W3342BD
W3612BD	W3615BD	W3618BD	W3621BD	W3624BD	W3627BD	W3630BD	W3636BD	W3642BD

Butt Door Cabinets - 24" Deep

12" High	15" High	18" High	21" High	24" High	27" High
WD3012BD	WD3015BD	WD3018BD	WD3021BD	WD3024BD	WD3027BD
WD3312BD	WD3315BD	WD3318BD	WD3321BD	WD3324BD	WD3327BD
WD3612BD	WD3615BD	WD3618BD	WD3621BD	WD3624BD	WD3627BD

CSWOU - Wall Open Unit

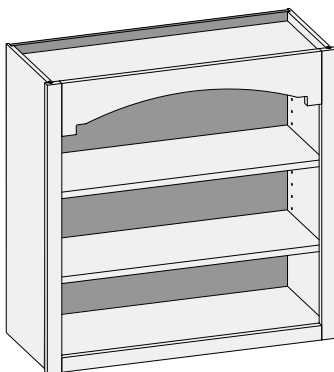

Custom Size Ranges
 Width: 15" – 48"
 Height: 30" – 72"
 Depth: 5-1/2" – 27"

- Available with valance designs on top rail (see pg. 12.6 for Valance Options). To order specify using CWS designations associated with the valance designs.
- Top rail is 5-1/2" for all valance designs.
- If no valance design is selected, top rail is 1-1/2" wide.
- Minimum width is 15".
- 18" – 24" high has one shelf.
- 24-1/16" – 36" high has two shelves.
- 36-1/16" – 48" high has three shelves.
- 48-1/16" – 59-15/16" high has four shelves.
- 60" – 72" high has five shelves.

Wall Options Key: EXP = Exposed End(s) FL = Flush End(s) FUE = Flush Unexposed End(s) PFD = Prep for False Door EXT = Extended Stile(s)
 OS = Omit Shelving NSH = No Shelf Holes WS = Solid Wood Shelves MI = Matching Interior NB = Natural Finished Bottom

W/CSWCS - Wall Cabinet w/Center Stile

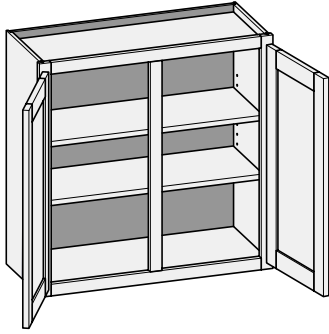

Custom Size Ranges
 Width: 27" – 48"
 Height: 12" – 72"
 Depth: 5-1/2" – 27"

- 12" – 18" high has no shelves.
- 18-1/16" – 24" high has one shelf.
- 24-1/16" – 36" high has two shelves.
- 36-1/16" – 48" high has three shelves.
- 48-1/16" – 60" high has four shelves.
- 60-1/16" – 72" high has five shelves.

12 -1/2" Deep

12" High	15" High	18" High	21" High	24" High	27" High	30" High	36" High	42" High
W3012	W3015	W3018	W3021	W3024	W3027	W3030	W3036	W3042
W3312	W3315	W3318	W3321	W3324	W3327	W3330	W3336	W3342
W3612	W3615	W3618	W3621	W3624	W3627	W3630	W3636	W3642
W3912	W3915	W3918	W3921	W3924	W3927	W3930	W3936	W3942
W4212	W4215	W4218	W4221	W4224	W4227	W4230	W4236	W4242
W4812	W4815	W4818	W4821	W4824	W4827	W4830	W4836	W4842

24" Deep

12" High	15" High	18" High	21" High	24" High	27" High
WD3012	WD3015	WD3018	WD3021	WD3024	WD3027
WD3312	WD3315	WD3318	WD3321	WD3324	WD3327
WD3612	WD3615	WD3618	WD3621	WD3624	WD3627
WD3912	WD3915	WD3918	WD3921	WD3924	WD3927

W/CSW2CS - Wall Cabinet w/Two Center Stiles

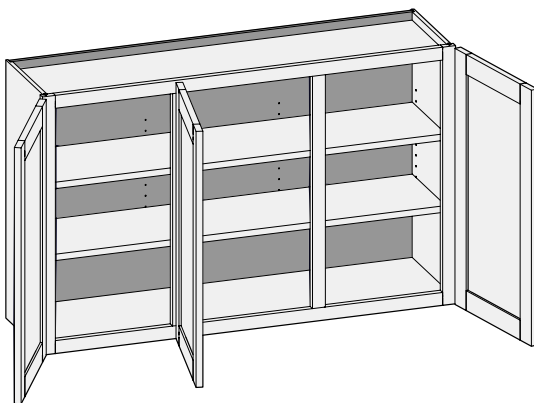

Custom Size Ranges
 Width: 48" – 72"
 Height: 12" – 72"
 Depth: 5-1/2" – 27"

- Additional shelf holes are provided in cabinet back to support wide shelves.
- Doors hinged on center stile require 1/2" overlay hinges for 1-1/4" or 1-3/8" overlay.
- 12" – 18" high has no shelves.
- 18-1/16" – 24" high has one shelf.
- 24-1/16" – 36" high has two shelves.
- 36-1/16" – 48" high has three shelves.
- 48-1/16" – 60" high has four shelves.
- 60-1/16" – 72" high has five shelves.
- Unavailable Options: WS.

30" High	36" High	42" High
W5130	W5136	W5142
W5430	W5436	W5442
W5730	W5736	W5742
W6030	W6036	W6042
W6330	W6336	W6342
W6630	W6636	W6642
W6930	W6936	W6942
W7230	W7236	W7242

Wall Options Key: EXP = Exposed End(s) FL = Flush End(s) FUE = Flush Unexposed End(s) PFD = Prep for False Door EXT = Extended Stile(s)
 OS = Omit Shelving NSH = No Shelf Holes WS = Solid Wood Shelves MI = Matching Interior NB = Natural Finished Bottom

WBC/CSWBC - Wall Blind Corner

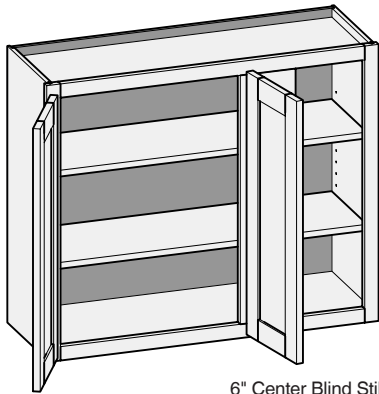

6" Center Blind Stile

Custom Size Ranges
 Single Door Width: 27" – 48"
 Butt Door Width: 36" – 48"
 Height: 12" – 72"
 Depth: 5-1/2" – 27"
 Functional Opening: 12" – 38"

- Units are reversible (left shown).
- Specify functional opening width between 12" and 38".
- Minimum blind opening is 1".
- 12" – 18" high has no shelves.
- 18-1/16" – 24" high has one shelf.
- 24-1/16" – 36" high has two shelves.
- 36-1/16" – 48" high has three shelves.
- 48-1/16" – 60" high has four shelves.
- 60-1/16" – 72" high has five shelves.
- Specify single or butt doors when functional opening width is 24".

Single Door Cabinets - 12-1/2" Deep

30" High	36" High	42" High
WBC2730	WBC2736	WBC2742
WBC3030	WBC3036	WBC3042
WBC3630	WBC3636	WBC3642

Butt Door Cabinets - 12-1/2" Deep

30" High	36" High	42" High
WBC4230BD	WBC4236BD	WBC4242BD
WBC4830BD	WBC4836BD	WBC4842BD

WBC/CSWBCCS - Wall Blind Corner w/Center Stile

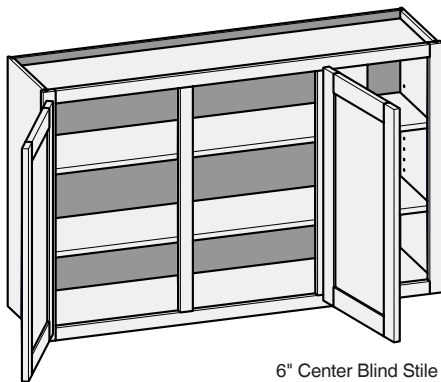

6" Center Blind Stile

Custom Size Ranges
 Width: 36" – 48"
 Height: 12" – 72"
 Depth: 5-1/2" – 27"

- Units are reversible (left shown).
- Designed to be used with adjacent 12-1/2" deep cabinet.
- 7-1/2" blind opening (fixed).
- 12" – 18" high has no shelves.
- 18-1/16" – 24" high has one shelf.
- 24-1/16" – 36" high has two shelves.
- 36-1/16" – 48" high has three shelves.
- 48-1/16" – 60" high has four shelves.
- 60-1/16" – 72" high has five shelves.

12-1/2" Deep

30" High	36" High	42" High
WBC4230	WBC4236	WBC4242
WBC4830	WBC4836	WBC4842

Wall Options Key: EXP = Exposed End(s) FL = Flush End(s) FUE = Flush Unexposed End(s) PFD = Prep for False Door EXT = Extended Stile(s)
 OS = Omit Shelving NSH = No Shelf Holes WS = Solid Wood Shelves MI = Matching Interior NB = Natural Finished Bottom

WCS/CSWCSE - Wall Corner Single Entry

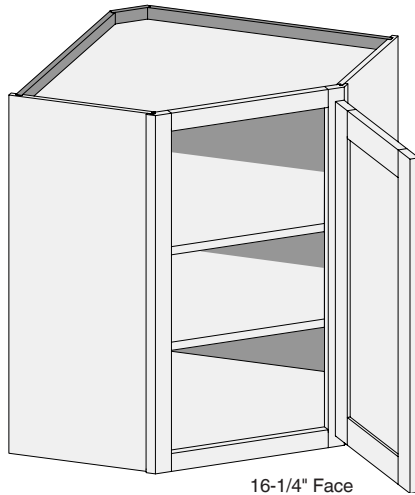

16-1/4" Face
17-3/8" Frame
Width

Custom Size Ranges
Width: 24", 27"
Height: 24" – 72"
Depth: 24", 27"

- WCS24 units have 12-1/2" deep sides.
- WCS27 units have 15-1/2" deep sides.
- Shelf-mounted wood susan shelves are available. See Section 11 – Accessories.
- When ordered with 1-1/4" and 1-3/8" overlay applications (with or without hinges), cabinets will have their door sized as 1/2" overlay in width only to ensure adequate clearance.
- 24" – 36" high has two shelves.
- 36-1/16" – 48" high has three shelves.
- 48-1/16" – 60" high has four shelves.
- 60-1/16" – 72" high has five shelves.
- Unavailable Options: PFD and EXT.

30" High	36" High	42" High
WCS2430	WCS2436	WCS2442
WCS2730	WCS2736	WCS2742

WCCLS – Wall Corner Single Entry with Lazy Susan

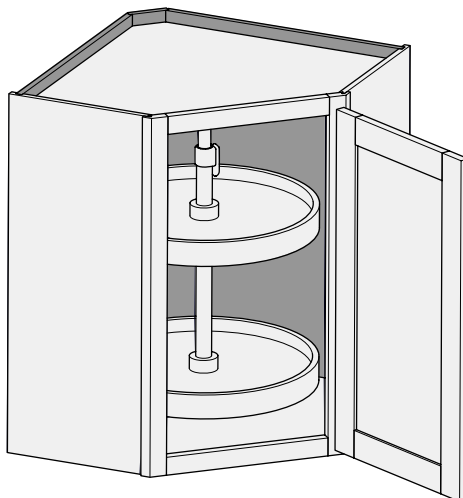

16-1/4" Face
17-3/8" Frame
Width

Custom Size Ranges
Width: 24", 27"
Height: 30"
Depth: 24", 27"

- Cabinet top and bottom is pre-drilled to accept hub assembly. Location and installation are greatly simplified.
- Cabinet includes 18" diameter entry level plastic susan with two independently rotating shelves mounted on a center pole.
- White susan shelves feature a self-lubricating nylon bearing and tool-free height adjustment.
- Size customization is not available due to susan size constraints.
- WCCLS24 has 12-1/2" deep sides.
- WCCLS27 has 15-1/2" deep sides.
- When ordered with 1-1/4" and 1-3/8" overlay applications (with or without hinges), cabinets will have their door sized as 1/2" overlay in width only to ensure adequate clearance.
- Not available with inset applications.
- Unavailable Options: PFD and EXT.

Cabinet Code
WCCLS2430
WCCLS2730

WCP/CSWCP - Wall Corner Pie Cut

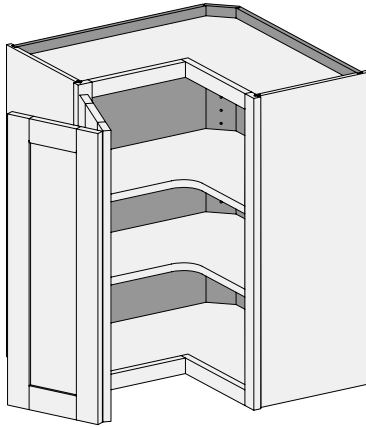

Custom Size Ranges

24" Wide:
 Width: 24" – 27"
 Height: 24" – 72"
 Depth: 24" – 27"

27" Wide:
 Width: 27" – 30"
 Height: 24" – 72"
 Depth: 27" – 30"

- WCP24 unit has 12-1/2" deep sides.
- WCP27 unit has 15-1/2" deep sides.
- When hinges are ordered with 1-1/4" and 1-3/8" overlay applications, cabinets will have their doors sized as 1/2" overlay in width only to ensure proper clearance.
- If hinges are not specified, 1-1/4" and 1-3/8" overlay sizing rules apply. These overlays require adequate clearance for door functionality between corner and adjacent cabinets. Use filler or extended stiles accordingly.
- CSWCP available with custom size legs. Specify width (left dimension) and depth (right dimension). Side depth remains fixed; front frame pie cut opening adjusts as size changes.
- Wood shelf upgrade not available with CSWCP.
- Shelf-mounted wood susan shelves are available. See Section 11 – Accessories.
- Optional Soss hinges available.
- 24" – 36" high has two shelves.
- 36-1/16" – 48" high has three shelves.
- 48-1/16" – 60" high has four shelves.
- 60-1/16" – 72" high has five shelves.
- Unavailable Option: PFD.

WCP24

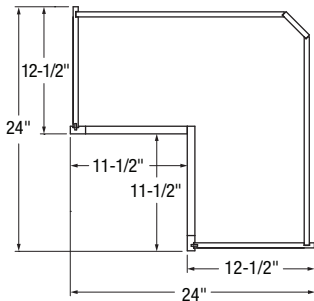

WCP27

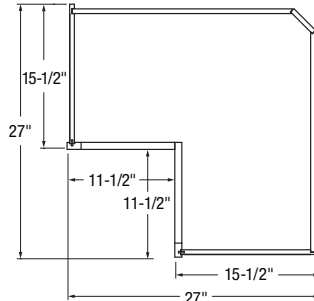

CSWCP24

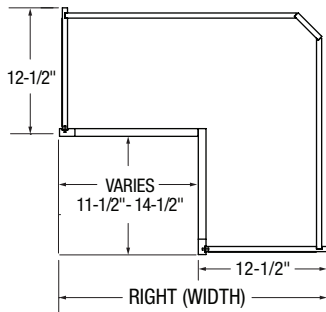

CSWCP27

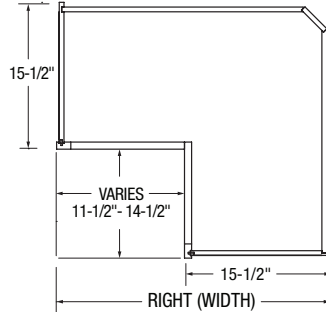

Custom Size Ranges		
	12-1/2" deep sides	15-1/2" deep sides
Width	24" – 27"	27" – 30"
Height	24" – 48"	24" – 48"
Depth	24" – 27"	27" – 30"

	30" High	36" High	42" High
	WCP2430	WCP2436	WCP2442
	WCP2730	WCP2736	WCP2742

Wall Options Key: EXP = Exposed End(s) FL = Flush End(s) FUE = Flush Unexposed End(s) PFD = Prep for False Door EXT = Extended Stile(s)
 OS = Omit Shelving NSH = No Shelf Holes WS = Solid Wood Shelves MI = Matching Interior NB = Natural Finished Bottom

WCPLS/CSWCPLS – Wall Corner Lazy Susan

Custom Size Ranges
Width: 24", 27"
Height: 30"
Depth: 24", 27"

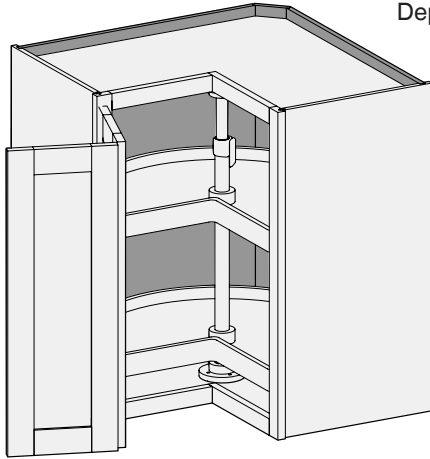

- Cabinet top and bottom is pre-drilled to accept hub assembly.
- Cabinet includes entry level plastic susan with two independently rotating kidney shelves mounted on a center pole.
- White susan shelves feature a self-lubricating nylon bearing and tool-free height adjustment.
- WCPLS24 has 12-1/2" deep sides and 18" diameter susan shelves.
- WCPLS27 has 15-1/2" deep sides and 24" diameter susan shelves.
- Height customization is not available due to susan unit size constraints.
- When hinges are ordered with 1-1/4" and 1-3/8" overlay applications, cabinets will have their door sized as 1/2" overlay in width only.
- If hinges are not specified, 1-1/4" and 1-3/8" overlay sizing rules apply. These overlays require adequate clearance for door functionality between corner and adjacent cabinets. Use filler or extended stiles accordingly.
- Not available with inset applications.
- Optional Soss hinges available.
- Unavailable Option: PFD.

WCLS2430

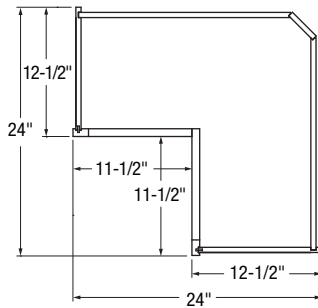

WCLS2730

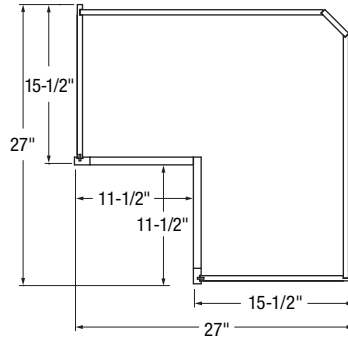

Cabinet Code
WCPLS2430
WCPLS2730

WAE/CSWAE - Wall Angle End

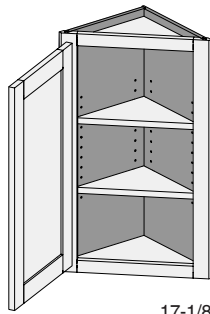

17-1/8" Face
17-11/16" Frame Width

2-3/32" Stiles

Custom Size Ranges
Width: 12-1/2"
Height: 12" – 72"
Depth: 12-1/2"

- Concealed inset hinges are not available.
- 12" – 18" high has no shelves.
- 18-1/16" – 24" high has one shelf.
- 24-1/16" – 36" high has two shelves.
- 36-1/16" – 48" high has three shelves.
- 48-1/16" – 60" high has four shelves.
- 60-1/16" – 72" high has five shelves.
- Unavailable Options: EXP, FL, FUE, PFD, EXT.

30" High	36" High	42" High
WAE1230	WAE1236	WAE1242

WOS/CSWOS - Wall Open Shelf

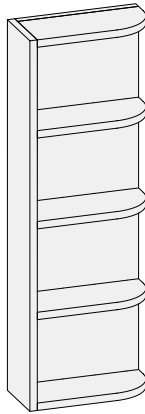

Custom Size Ranges
Width: 6"
Height: 12" – 48"
Depth: 12-1/2" – 27"

- Standard as shown. No options available.
- Reversible.
- 3/4" matching specie plywood with dowel construction.
- Exposed edges are banded with matching specie veneer.
- Hard Maple plywood utilized for Hard and Soft Maple lines.
- 12" – 17-15/16" high has two shelves.
- 18" – 23-15/16" high has three shelves.
- 24" – 35-15/16" high has four shelves.
- 36" – 48" high has five shelves.
- Matching Interior (MI) Standard.

12-1/2" Deep		
30" High	36" High	42" High
WOS0630	WOS0636	WOS0642

WOSST/CSWOSST - Wall Open Shelf Square Top

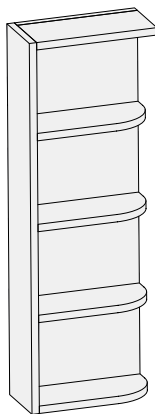

Custom Size Ranges
Width: 6"
Height: 12" – 48"
Depth: 12-1/2" – 27"

- Standard as shown. No options available.
- 3/4" matching specie plywood with dowel construction.
- Exposed edges are banded with matching specie veneer.
- Hard Maple plywood utilized for Hard and Soft Maple lines.
- 12" – 17-15/16" high has two shelves.
- 18" – 23-15/16" high has three shelves.
- 24" – 35-15/16" high has four shelves.
- 36" – 48" high has five shelves.
- Matching Interior (MI) Standard.

12-1/2" Deep		
30" High	36" High	42" High
WOSST0630	WOSST0636	WOSST0642

Wall Options Key: EXP = Exposed End(s) FL = Flush End(s) FUE = Flush Unexposed End(s) PFD = Prep for False Door EXT = Extended Stile(s)
OS = Omit Shelving NSH = No Shelf Holes WS = Solid Wood Shelves MI = Matching Interior NB = Natural Finished Bottom

CSWS3D - Wall Spice Three Drawer w/Butt Doors

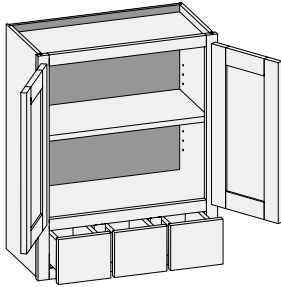

Custom Size Ranges
 Width: 24" – 29-15/16"
 Height: 30" – 72"
 Depth: 5-1/2" – 27"

- No drawer slides.
- When height changes, upper opening height changes. Lower opening height fixed at 5".
- 30" – 35" high has one shelf.
- 35-1/16" – 42" high has two shelves.
- 42-1/16" – 48" high has three shelves.
- 48-1/16" – 60" high has four shelves.
- 60-1/16" – 72" high has five shelves.

CSWS4D - Wall Spice Four Drawer w/Butt Doors

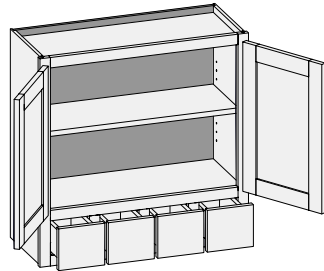

Custom Size Ranges
 Width: 30" – 35-15/16"
 Height: 30" – 72"
 Depth: 5-1/2" – 27"

- No drawer slides.
- When height changes, upper opening height changes. Lower opening height fixed at 5".
- 30" – 35" high has one shelf.
- 35-1/16" – 42" high has two shelves.
- 42-1/16" – 48" high has three shelves.
- 48-1/16" – 60" high has four shelves.
- 60-1/16" – 72" high has five shelves.

CSWS5D - Wall Spice Five Drawer w/Butt Doors

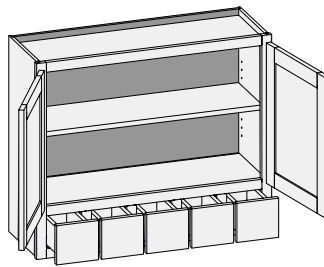

Custom Size Ranges
 Width: 36"
 Height: 30" – 72"
 Depth: 5-1/2" – 27"

- No drawer slides.
- When height changes, upper opening height changes. Lower opening height fixed at 5".
- 30" – 35" high has one shelf.
- 35-1/16" – 42" high has two shelves.
- 42-1/16" – 48" high has three shelves.
- 48-1/16" – 60" high has four shelves.
- 60-1/16" – 72" high has five shelves.

CSWRC3 – Wall w/ 3 Sided Recessed Back

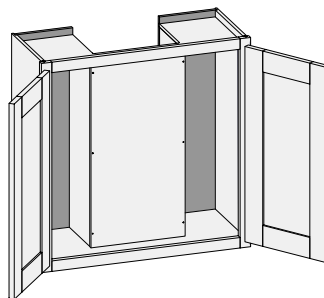

Custom Size Ranges
 Width: 24" – 36"
 Height: 12" – 48"
 Depth: 12" – 27"

- Designed to accommodate and conceal ductwork, electric or plumbing supply lines.
- Front panel is removable for installation and access to supply lines.
- To customize recess size and location, specify A, B and C.
- Recess can be centered or offset from either side.
- Minimum dimensions for A, B and C: 2".
- Maximum dimensions for A and B: Cabinet width minus A + B equal to or greater than 2".
- Maximum dimension for C: Cabinet depth minus 2".
- No shelves.
- Specify single or butt doors on custom size cabinets 24" wide.
- Unavailable Options: PFD and MI.

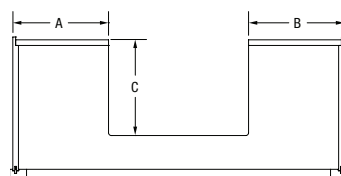

WRC3 Top View

Wall Options Key: EXP = Exposed End(s) FL = Flush End(s) FUE = Flush Unexposed End(s) PFD = Prep for False Door EXT = Extended Stile(s)
 OS = Omit Shelving NSH = No Shelf Holes WS = Solid Wood Shelves MI = Matching Interior NB = Natural Finished Bottom

W1D/CSW1D - Wall One Drawer

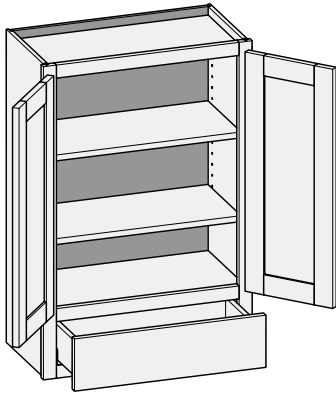

Custom Size Ranges
 Single Door Width: 12" – 24"
 Butt Door Width: 24" – 36"
 Height: 30" – 72"
 Depth: 12", 12-1/2",
 15", 18", 21", 24"

- When height changes, upper opening height changes. Lower opening height fixed at 5".
- 30" – 35" high has one shelf.
- 35-1/16" – 47" high has two shelves.
- 47-1/16" – 59" high has three shelves.
- 69-1/16" – 72" high has four shelves.
- Specify single or butt doors on custom size cabinets 24" wide.
- Unavailable Option: PFD.

Single Door Cabinets – 12-1/2" Deep		
48" High	54" High	60" High
W1D1548	W1D1554	W1D1560
W1D1848	W1D1854	W1D1860
W1D2148	W1D2154	W1D2160
W1D2448	W1D2454	W1D2460

Butt Door Cabinets – 12-1/2" Deep		
48" High	54" High	60" High
W1D2448BD	W1D2454BD	W1D2460BD
W1D2748BD	W1D2754BD	W1D2760BD
W1D3048BD	W1D3054BD	W1D3060BD
W1D3348BD	W1D3354BD	W1D3360BD
W1D3648BD	W1D3654BD	W1D3660BD

W1D/CSW1DCS - Wall One Drawer w/Center Stile

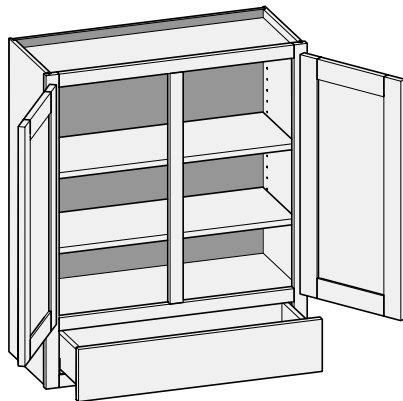

Custom Size Ranges
 Width: 27" – 36"
 Height: 30" – 72"
 Depth: 12", 12-1/2",
 15", 18", 21", 24"

- When height changes, upper opening height changes. Lower opening height fixed at 5".
- 30" – 35" high has one shelf.
- 35-1/16" – 47" high has two shelves.
- 47-1/16" – 59" high has three shelves.
- 59-1/16" – 72" high has four shelves.
- Unavailable Option: PFD.

48" High	54" High	60" High
W1D2748	W1D2754	W1D2760
W1D3048	W1D3054	W1D3060
W1D3348	W1D3354	W1D3360
W1D3648	W1D3654	W1D3660

Wall Options Key: EXP = Exposed End(s) FL = Flush End(s) FUE = Flush Unexposed End(s) PFD = Prep for False Door EXT = Extended Stile(s)
 OS = Omit Shelving NSH = No Shelf Holes WS = Solid Wood Shelves MI = Matching Interior NB = Natural Finished Bottom

W2D/CSW2D - Wall Two Drawer w/Butt Doors

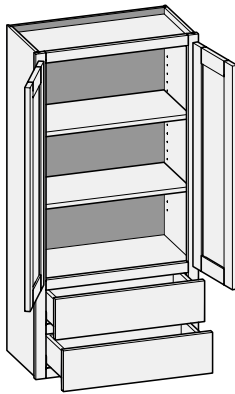

Custom Size Ranges
 Width: 24" – 36"
 Height: 30" – 72"
 Depth: 12", 12-1/2",
 15", 18", 21", 24"

- When height changes, upper opening height changes. Lower opening heights fixed at 5".
- 30" – 41" high has one shelf.
- 41-1/16" – 47" high has two shelves.
- 47-1/16" – 59" high has three shelves.
- 59-1/16" – 72" high has four shelves.
- Specify single or butt doors on custom size cabinets 24" wide.
- Unavailable Option: PFD.

Single Door Cabinets – 12-1/2" Deep		
48" High	54" High	60" High
W2D1548	W2D1554	W2D1560
W2D1848	W2D1854	W2D1860
W2D2148	W2D2154	W2D2160
W2D2448	W2D2454	W2D2460

Butt Door Cabinets – 12-1/2" Deep		
48" High	54" High	60" High
W2D2448BD	W2D2454BD	W2D2460BD
W2D2748BD	W2D2754BD	W2D2760BD
W2D3048BD	W2D3054BD	W2D3060BD
W2D3348BD	W2D3354BD	W2D3360BD
W2D3648BD	W2D3654BD	W2D3660BD

W2D/CSW2DCS - Wall Two Drawer w/Center Stile

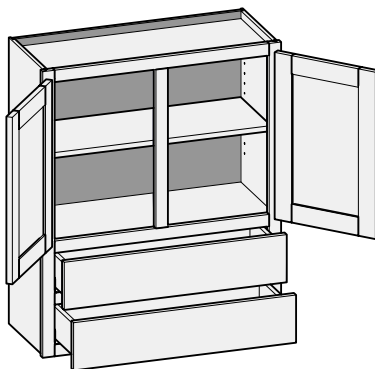

Custom Size Ranges
 Width: 27" – 36"
 Height: 30" – 72"
 Depth: 12", 12-1/2",
 15", 18", 21", 24"

- When cabinet height changes the upper opening changes. Lower opening heights fixed at 5".
- 30" – 41" high has one shelf.
- 41-1/16" – 47" high has two shelves.
- 47-1/16" – 59" high has three shelves.
- 59-1/16" – 72" high has four shelves.
- Unavailable Option: PFD.

48" High	54" High	60" High
W2D2748	W2D2754	W2D2760
W2D3048	W2D3054	W2D3060
W2D3348	W2D3354	W2D3360
W2D3648	W2D3654	W2D3660

WOBS/CSWOBS - Wall Open Bookshelf

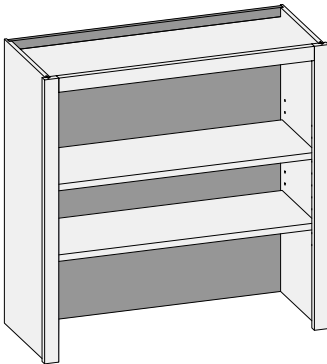

Custom Size Ranges
 Width: 9" – 36"
 Height: 12" – 96"
 Depth: 5-1/2" – 27"

- Solid wood shelves not available with matching specie interior option.
- <24" has no shelves.
- 24-1/16" – 35" has one shelf.
- 35-1/16" – 47" high has two shelves.
- 47-1/16" – 59" high has three shelves.
- 59-1/16" – 72" high has four shelves.
- 72-1/16" – 84" high has five shelves.
- 84-1/16" – 96" high has six shelves.

12-1/2" Deep		
48" High	54" High	60" High
WOBS1548	WOBS1554	WOBS1560
WOBS1848	WOBS1854	WOBS1860
WOBS2148	WOBS2154	WOBS2160
WOBS2448	WOBS2454	WOBS2460
WOBS2748	WOBS2754	WOBS2760
WOBS3048	WOBS3054	WOBS3060
WOBS3348	WOBS3354	WOBS3360
WOBS3648	WOBS3654	WOBS3660

CSWOBSCS – Wall Open Bookshelf w/Center Stile

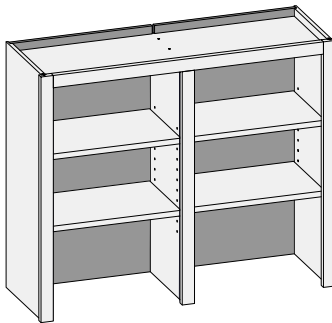

Custom Size Ranges
 Width: 36" – 72"
 Height: 12" – 96"
 Depth: 5-1/2" – 27"

- Fixed vertical partition with independently adjustable shelves.
- Solid wood shelves not available with matching specie interior option.
- <24" has no shelves.
- 24-1/6" – 35" high has two shelves.
- 35-1/16" – 47" high has four shelves.
- 47-1/16" – 59" high has six shelves.
- 59-1/16" – 72" high has eight shelves.
- 72-1/16" – 84" high has ten shelves.
- 84-1/16" – 96" high has twelve shelves.

Wall Options Key: EXP = Exposed End(s) FL = Flush End(s) FUE = Flush Unexposed End(s) PFD = Prep for False Door EXT = Extended Stile(s)
 OS = Omit Shelving NSH = No Shelf Holes WS = Solid Wood Shelves MI = Matching Interior NB = Natural Finished Bottom

CSWMB - Wall Microwave Built-in w/Butt Doors

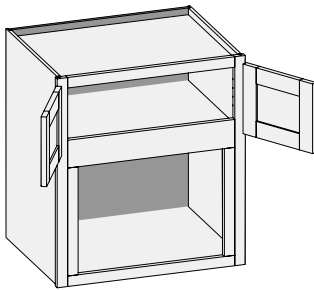

4" Middle Rail

Custom Size Ranges
 Width: 24" – 36"
 Height: 30" – 72"
 Depth: 18" – 27"

- Bottom opening height 14" on 30" – 35-15/16" height, 15-1/2" on all other heights. Trimmable to midrail, increase opening height by 2-1/2".
- Bottom opening width 6" less than cabinet width. Trimmable to 3".
- 30" – 42" high has no shelves.
- 42-1/16" – 54" high has one shelf.
- 54-1/16" – 66" high has two shelves.
- 66-1/16" – 72" high has three shelves.
- Unavailable option: WS.

CSWMBCS - Wall Microwave Built-in w/Center Stile

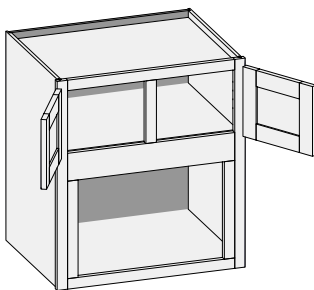

Middle Rail

Custom Size Ranges
 Width: 27" – 36"
 Height: 30" – 72"
 Depth: 18" – 27"

- Bottom opening height 14" on 30" – 35-15/16" height; 15-1/2" on all others. Trimmable to midrail, increase opening height to 2-1/2".
- Bottom opening width 6" less than cabinet width. Trimmable to 3" less than cabinet width.
- 30" – 42" high has no shelves.
- 42-1/5" – 54" high has one shelf.
- 54-1/16" – 66" high has two shelves.
- 66-1/16" – 72" high has three shelves.
- Unavailable option: WS.

CSWMWS - Wall Microwave with Shelf w/Butt Doors

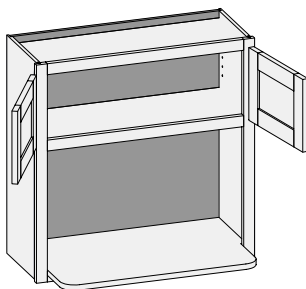

Custom Size Ranges
 Width: 24" – 36"
 Height: 30" – 72"
 Depth: 5-1/2" – 27"

- 18" deep matching specie plywood microwave shelf.
- Soft Maple uses Hard Maple plywood shelf.
- When height changes, upper opening height changes. Lower opening height fixed at 16-1/2".
- Edge of lower shelf is plywood banded with matching specie veneer.
- 30" – 42" high has no shelves.
- 42-1/6" – 54" high has one shelf.
- 54-1/16" – 66" high has two shelves.
- 66-1/16" – 72" high has three shelves.
- Unavailable options: PFD and WS.

CSWMWCS - Wall Microwave with Shelf w/Center Stile

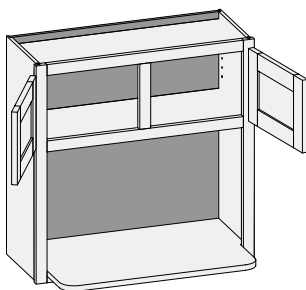

Custom Size Ranges
 Width: 27" – 36"
 Height: 30" – 72"
 Depth: 5-1/2" – 27"

- 18" deep matching specie plywood microwave shelf.
- Soft Maple uses Hard Maple plywood shelf.
- When height changes, upper opening height changes. Lower opening height fixed at 16-1/2".
- Edge of lower shelf is plywood banded with matching specie veneer.
- 30" – 42" high no shelves.
- 42-1/16" – 54" high has one shelf.
- 54-1/16" – 66" high has two shelves.
- 66-1/16" – 72" high has three shelves.
- Unavailable options: PFD and WS.

Wall Options Key: EXP = Exposed End(s) FL = Flush End(s) FUE = Flush Unexposed End(s) PFD = Prep for False Door EXT = Extended Stile(s)
 OS = Omit Shelving NSH = No Shelf Holes WS = Solid Wood Shelves MI = Matching Interior NB = Natural Finished Bottom

TTW/CSTTW - Two Tiered Wall

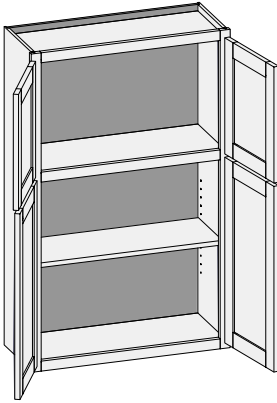

Custom Size Ranges
 Single Door Width: 9" – 24"
 Butt Door Width: 24" – 36"
 Height: 48" – 72"
 Depth: 5-1/2" – 27"

- When height changes, lower opening height changes.
 - ◆ Upper opening height fixed at 16-1/2" with inset, 1/4" and 1/2" overlay.
 - ◆ Upper opening height fixed at 16" with 1-1/4" and 1-3/8" overlay.
- Lower section designed to align with adjacent wall cabinets. Add 18" to adjacent cabinet to determine TTW cabinet height.
- 48" – 60" high has two shelves.
- 60-1/16" – 72" high has three shelves.
- Specify single or butt doors on custom size cabinets 24" wide.

Single Door Cabinets – 12-1/2" Deep	
48" High	
TTW1248	TTW2148
TTW1548	TTW2448
TTW1848	

Butt Door Cabinets – 12-1/2" Deep	
48" High	
TTW2448BD	TTW3348BD
TTW2748BD	TTW3648BD
TTW3048BD	

TTW/CSTTWCS - Two Tiered Wall w/Center Stile

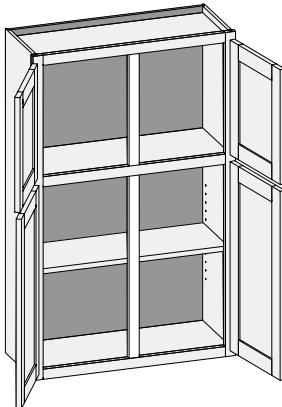

Custom Size Ranges
 Width: 27" – 36"
 Height: 48" – 72"
 Depth: 5-1/2" – 27"

- When height changes, lower opening height changes.
 - ◆ Upper opening height fixed at 16-1/2" with inset, 1/4" and 1/2" overlay.
 - ◆ Upper opening height fixed at 16" with 1-1/4" and 1-3/8" overlay.
- Lower section designed to align with adjacent wall cabinets. Add 18" to adjacent cabinet to determine TTW cabinet height.
- 48" – 60" high has two shelves.
- 60-1/16" – 72" high has three shelves.

12-1/2" Deep	
48" High	
TTW2748	TTW3948
TTW3048	TTW4248
TTW3348	TTW4548
TTW3648	TTW4848

Wall Options Key: EXP = Exposed End(s) FL = Flush End(s) FUE = Flush Unexposed End(s) PFD = Prep for False Door EXT = Extended Stile(s)
 OS = Omit Shelving NSH = No Shelf Holes WS = Solid Wood Shelves MI = Matching Interior NB = Natural Finished Bottom

TTWCSE/CSTTWCE - Two Tiered Wall Corner Single Entry

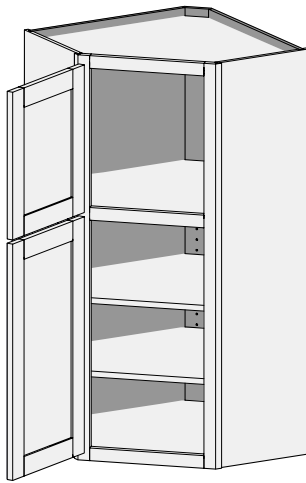

16-1/4" Face
17-3/8" Frame
Width

Custom Size Ranges
Width: 24", 27"
Height: 48" – 72"
Depth: 24", 27"

48" High
TTWCSE2448
TTWCSE2748

- When height changes, lower opening height changes.
 - ♦ Upper opening height fixed at 16-1/2" with inset, 1/4" and 1/2" overlay.
 - ♦ Upper opening height fixed at 16" with 1-1/4" and 1-3/8" overlay.
- TTWCSE24 units have 12-1/2" deep sides.
- TTWCSE27 units have 15-1/2" deep sides.
- Susan option is not available.
- When ordered in 1-1/4" and 1-3/8" overlay applications (with or without hinges), cabinets will have their doors sized as 1/2" overlay in width only to ensure adequate clearance.
- Lower section designed to align with adjacent wall cabinets. Add 18" to adjacent cabinet to determine TTW cabinet height.
- 48" – 60" high has two shelves.
- 60-1/16" – 72" high has three shelves.
- Unavailable options: EXT and PFD.

TTWCP/CSTTWCP - Two Tiered Wall Corner Pie Cut

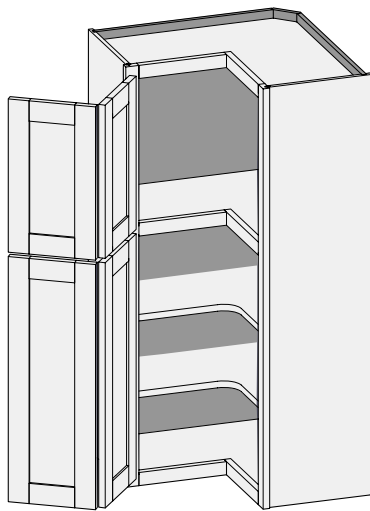

Custom Size Ranges
Width: 24", 27"
Height: 48" – 72"
Depth: 24", 27"

48" High
TTWCP2448
TTWCP2748

- When height changes, lower opening height changes.
 - ♦ Upper opening height fixed at 16-1/2" with inset, 1/4" and 1/2" overlay.
 - ♦ Upper opening height fixed at 16" with 1-1/4" and 1-3/8" overlay.
- TTWCP24 units have 12-1/2" deep sides.
- TTWCP27 units have 15-1/2" deep sides.
- Susan option is not available.
- When hinges are ordered in 1-1/4" and 1-3/8" overlay applications, cabinets will have their doors sized as 1/2" overlay in width only.
- If hinges are not specified, 1-1/4" and 1-3/8" overlay sizing rules apply. These overlays require adequate clearance for door functionality between corner and adjacent cabinets. Use filler or extended stiles accordingly.
- Lower section designed to align with adjacent wall cabinets. Add 18" to adjacent cabinet to determine TTW cabinet height.
- 48" – 60" high has two shelves.
- 60-1/16" – 72" high has three shelves.

CSRH - Range Hood w/Butt Doors

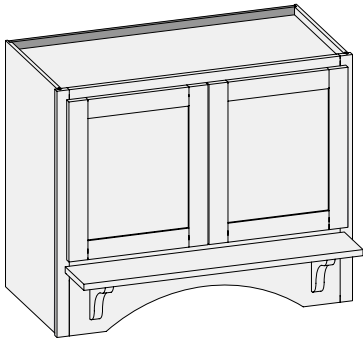

Custom Size Ranges
 Width: 30" – 36"
 Height: 24" – 48"
 Depth: 18" – 21"

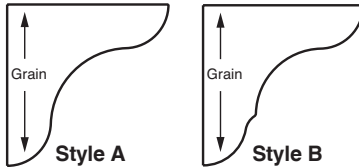

- Operable doors allow access to ventilation unit.
- Ventilators available through Stanisci Design. Phone Number: 248-572-6880.
- Roman Arch bottom rail standard - no options.
- Available with two bracket designs: Style A or B.
- Brackets are 1" thick, 6" high and 6" deep.
- Solid mantle shelf is 3/4" thick and 6-1/4" deep. Specify desired edge profile.
- Mantle shelf kit options (specify one):
 - Kit A - 2 Style A brackets and wood shelf
 - Kit B - 2 Style B brackets and wood shelf
 - Mantle shelf only
 - Style A only (pair)
 - Style B only (pair)
- Mantles and brackets not available on 24" – 29-15/16" high.

CSRHCS - Range Hood w/Center Stile

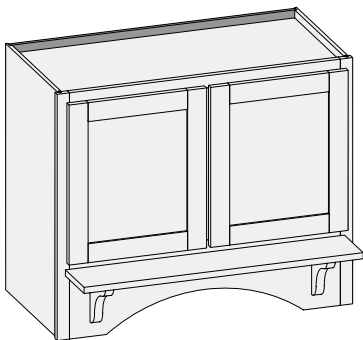

Custom Size Ranges
 Width: 36" – 48"
 Height: 24" – 48"
 Depth: 18" – 21"

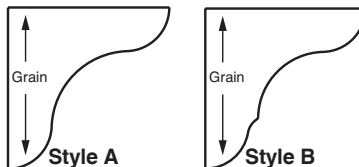

- Operable doors allow access to ventilation unit.
- Ventilators available through Stanisci Design. Phone Number: 248-572-6880.
- Roman Arch bottom rail standard - no options.
- Available with two bracket designs: Style A or B.
- Brackets are 1" thick, 6" high and 6" deep.
- Solid mantle shelf is 3/4" thick and 6-1/4" deep. Specify desired edge profile.
- Mantle shelf kit options (specify one):
 - Kit A - 2 Style A brackets and wood shelf
 - Kit B - 2 Style B brackets and wood shelf
 - Mantle shelf only
 - Style A only (pair)
 - Style B only (pair)
- Mantles and brackets not available on 24" – 29-15/16" high.

CSWDE - Wall Double Entry w/Butt Doors

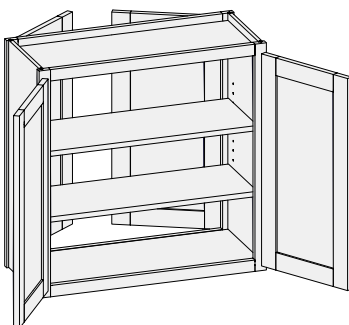

Custom Size Ranges
 Single Door Width: 9" – 24"
 Butt Door Width: 24" – 36"
 Height: 12" – 72"
 Depth: 12" – 27"

- 12" – 18" high has no shelves.
- 18-1/16" – 24" high has one shelf.
- 24-1/16" – 36" high has two shelves.
- 36-1/16" – 48" high has three shelves.
- 48-1/16" – 60" high has four shelves.
- 60-1/16" – 72" high has five shelves.
- Specify single or butt doors on custom size cabinets 24" wide.
- Unavailable options: PFD and WS.

Wall Options Key: EXP = Exposed End(s) FL = Flush End(s) FUE = Flush Unexposed End(s) PFD = Prep for False Door EXT = Extended Stile(s)
 OS = Omit Shelving NSH = No Shelf Holes WS = Solid Wood Shelves MI = Matching Interior NB = Natural Finished Bottom

WDE/CSWDECS - Wall Double Entry w/Center Stile

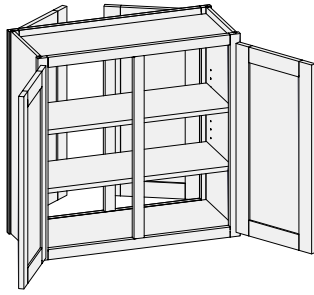

Custom Size Ranges
Width: 27" – 48"
Height: 12" – 72"
Depth: 12" – 27"

- 12" – 18" high has no shelves.
- 18-1/16" – 24" high has one shelf.
- 24-1/16" – 36" high has two shelves.
- 36-1/16" – 48" high has three shelves.
- 48-1/16" – 60" high has four shelves.
- 60-1/16" – 72" high has five shelves.
- Unavailable options: PFD and WS.

WXC/CSWXC - Wall X Cube Cabinet

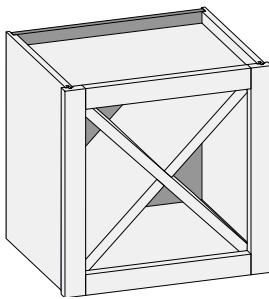

Custom Size Ranges
Width: 12", 15", 18"
Height: 12", 15", 18"
Depth: 5-1/2" – 15-1/2"

- "X" insert constructed from 3/4" matching specie plywood.
- When ordering custom size cabinets, width and height must be equal.
- Top and bottom rails extend into the opening 1/8" to conceal ends of "X" insert after installation.

12-1/2" Deep		
12" High	15" High	18" High
WXC1212	WXC1515	WXC1818

W1X/CSW1X - Wall One Door X Cube Cabinet

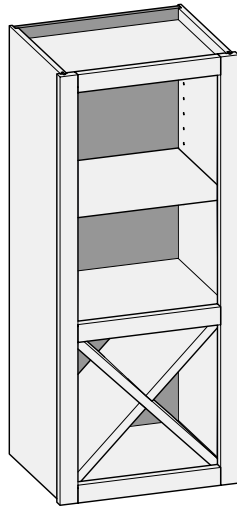

Custom Size Ranges
Width: 12", 15", 18"
Height: 30" – 72"
Depth: 5-1/2" – 15-1/2"

- When height changes, upper section increases.
- Lower section height is equal to the cabinet width to maintain "X" insert sizing.
- "X" insert constructed from 3/4" matching specie plywood.
- Top and bottom rails in lower section extend into the opening 1/8" to conceal ends of "X" insert after installation.
- See BOM app on Customer Business Portal for shelf quantity.

30" High	33" High	36" High	42" High	45" High	48" High	51" High	54" High	57" High	60" High
W1X1230	W1X1233	W1X1236	W1X1242	W1X1245	W1X1248	W1X1251	W1X1254	W1X1257	W1X1260
W1X1530	W1X1533	W1X1536	W1X1542	W1X1545	W1X1548	W1X1551	W1X1554	W1X1557	W1X1560
W1X1830	W1X1833	W1X1836	W1X1842	W1X1845	W1X1848	W1X1851	W1X1854	W1X1857	W1X1860

Wall Options Key: EXP = Exposed End(s) FL = Flush End(s) FUE = Flush Unexposed End(s) PFD = Prep for False Door EXT = Extended Stile(s)
OS = Omit Shelving NSH = No Shelf Holes WS = Solid Wood Shelves MI = Matching Interior NB = Natural Finished Bottom

CSWHKXS - Wall w/HK-XS Lift System

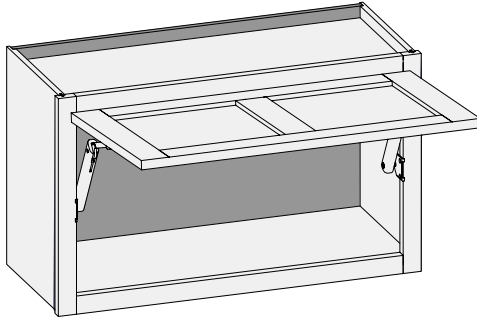

Custom Size Ranges
Width: 15" – 42"
Height: 12" – 24"
Depth: 6-1/2" – 27"

- Preconfigured units include Blum HK-XS Series lift system hardware and Blum COMPACT hinges.
- Door weight and design determine the strength and quantity of lift mechanisms provided.
- Cabinet width 15" – 24" are single panel door designs. 24-1/16" – 42" are two panels side by side door designs. Upcharges for 2 panel door apply.
- Rabbeted edge profiles and inset/prefit options are not available.
- 12" – 18" high has no shelves.
- 18-1/16" – 24" high has one shelf.

CSWHL - Wall w/ AVENTOS HL top Lift System

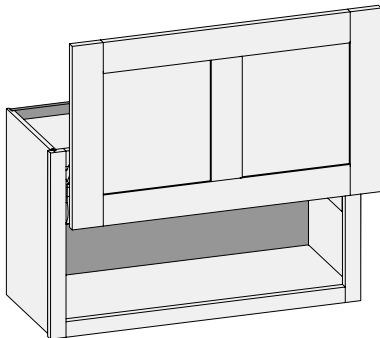

Custom Size Ranges
Width: 15" – 42"
Height: 12" – 33"
Depth: 12" – 27"
Door Height: 11-3/4" – 22-3/4"

- Preconfigured units include Blum AVENTOS HL top series lift system hardware.
- Door weight and design determine the lift kit provided.
- Door minimum and maximum height cannot be exceeded.
- Cabinet may not be valid if system calculated door weight exceeds minimum or maximum value.
- Cabinet width 15" – 24" are single panel door designs. 24-1/16" – 42" are two panels side by side door designs. Upcharges for 2 panel door apply.
- 12" – 18" high has no shelves.
- 18-1/16" – 23" high has one shelf.

CSWHK - Wall w/ AVENTOS HK top Lift System

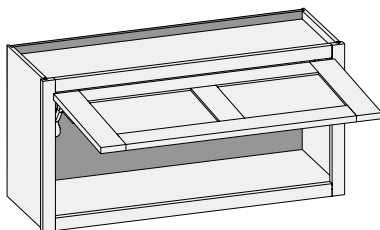

Custom Size Ranges
Width: 12" – 42"
Height: 8" – 24"
Depth: 10" – 27"

- Preconfigured units include Blum AVENTOS HL top series lift system hardware.
- Door weight and design determine the lift kit provided.
- Door minimum and maximum height cannot be exceeded.
- Cabinet may not be valid if system calculated door weight exceeds minimum or maximum value.
- Cabinet width 15" – 24" are single panel door designs. 24-1/16" – 42" are two panels side by side door designs. Upcharges for 2 panel door apply.
- 10" – 18" high has no shelves.
- 18-1/16" – 23" high has one shelf.

Wall Options Key: **EXP** = Exposed End(s) **FL** = Flush End(s) **FUE** = Flush Unexposed End(s) **PFD** = Prep for False Door **EXT** = Extended Stile(s)
OS = Omit Shelving **NSH** = No Shelf Holes **WS** = Solid Wood Shelves **MI** = Matching Interior **NB** = Natural Finished Bottom

CSWAC - Custom Size Wall Appliance Cabinet

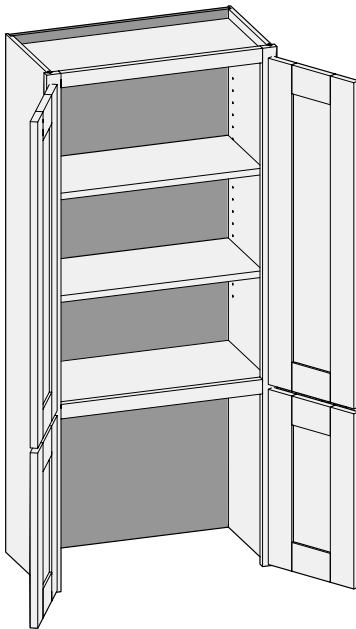

Custom Size Ranges
 Single Door Width: 12" – 24"
 Butt Door Width: 24" – 36"
 Height: 48" – 96"
 Depth: 5-1/2" – 30"
 Top Cab Height - 6" - 90"

- When ordering CSWAC specify the desired top cabinet height. On 1-1/4" & 1-3/8" overlay applications, CWS will adjust the front frame midrail location to ensure doors align with adjacent wall cabinet doors.
- Be sure to account for the countertop thickness when specifying overall cabinet height to ensure doors align properly.
- When ordering loose parts for this cabinet, use the BOM and specify the desired overlay to ensure the correct parts are ordered.
- Specify single or butt doors on custom size cabinets 24" wide.
- Shelf quantity is calculated for each opening height.
- Height <18" high has no shelves.
- Height 18" – 24" high has one shelf.
- Height 24-1/16" - 36" high has two shelves.
- Height 36-1/16" – 48" high has three shelves.
- Height 48-1/16" – 60" high has four shelves.
- Height 60-1/16" – 72" high has five shelves.
- Height 72-1/16" – 84" high has six shelves.
- Height >84" high has seven shelves.

CSWACHL - Wall Appliance Cabinet w/ AVENTOS HL top Lift System

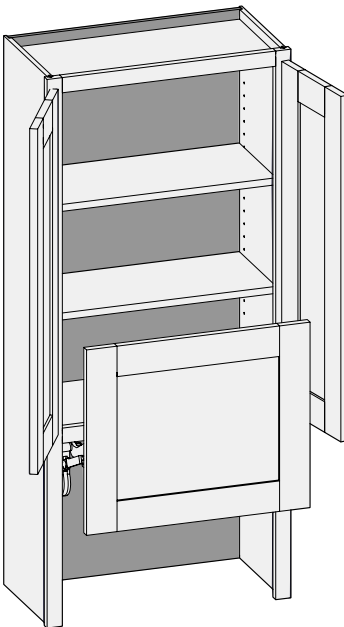

Custom Size Ranges
 Single Door Width: 12" – 24"
 Butt Door Width: 24" – 36"
 Height: 48" – 96"
 Depth: 5-1/2" – 30"
 Top Cab Height - 6" - 90"

- When ordering CSWAC specify the desired top cabinet height. On 1-1/4" & 1-3/8" overlay applications, CWS will adjust the front frame midrail location to ensure doors align with adjacent wall cabinet doors.
- Be sure to account for the countertop thickness when specifying overall cabinet height to ensure doors align properly.
- When ordering loose parts for this cabinet, use the BOM and specify the desired overlay to ensure the correct parts are ordered.
- Specify single or butt doors on custom size cabinets 24" wide.
- Shelf quantity is calculated for each opening height.
- Height <18" high has no shelves.
- Height 18" – 24" high has one shelf.
- Height 24-1/16" - 36" high has two shelves.
- Height 36-1/16" – 48" high has three shelves.
- Height 48-1/16" – 60" high has four shelves.
- Height 60-1/16" – 72" high has five shelves.
- Height 72-1/16" – 84" high has six shelves.
- Height >84" high has seven shelves.

CSWCO - Wall Case Only

Custom Size Ranges
 Width: 9" – 48"
 Height: 12" – 120"
 Depth: 5-1/2" – 30"

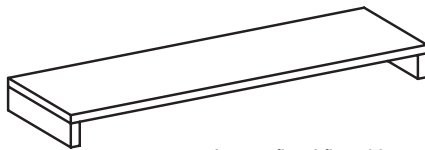
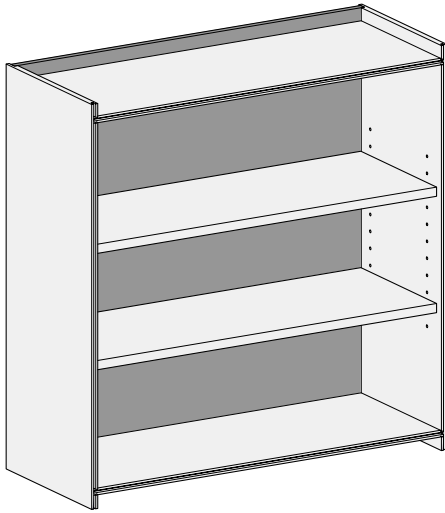

Loose fixed floor kits

- Customizable cabinet case for custom Wall and Tall applications.
- No front frame included – case only. Order custom size front frame and doors.
- Sides are machined with shelf holes.
- Loose fixed floor kits are sized to fit between sides. Plywood cleats included to mount floors as needed behind front frame openings. Floors include pre-inserted splines.
- Matching specie interior is not available over 96" high. White Birch UV topcoated material will be used.
- Custom quantities of fixed floor kits are available. Specify the quantity per cabinet.
- 12" – 18" high has no shelves.
- 18-1/16" – 24" high has one shelf.
- 24-1/16" – 36" high has two shelves.
- 36-1/16" – 48" high has three shelves.
- 48-1/16" – 60" high has four shelves.
- 60-1/16" – 72" high has five shelves.
- 72-1/16" – 84" high has six shelves.
- 84-1/16" – 96" high has seven shelves.
- 96-1/16" – 108" high has eight shelves.
- 108-1/16" – 120" high has nine shelves.
- Use Conestoga's online ordering system, Con-Nex or contact Customer Service for pricing of Case Only.

Advantage Base Cabinet Standard Features and Options

The information described below discusses some of the features and options of Advantage Base cabinets. Customers have the option to omit these standard features as well as add other design options, which can be quickly referenced at the bottom of each page in the Base Cabinet Section labeled “Base Options Key”. For more detailed descriptions and images of all available options see Options, Section 12 within this manual. The options described below are available on all Base cabinets unless specifically noted next to the individual cabinet as **Unavailable Options**.

Standard Shelving & Omit Shelving (OS) – 3/4” thick White Birch plywood shelving with a durable UV topcoat is standard with any Base cabinet with shelves. If shelving is not desired within a specific cabinet, indicate **Omit Shelving** when ordering.

5mm Shelf Holes & No Shelf Holes (NSH) – Pre-drilled 5mm shelf holes on 32mm centers are a standard feature of all Base cabinets with shelves. If shelf holes are not desired, indicate **No Shelf Holes** when ordering. **Note:** If shelving and shelf holes are not desired, both No Shelf Holes and Omit Shelving must be specified when ordering.

Cabinet Case Material Options – Most optional cabinet case materials will match the door, drawer front and face frame specie and are available with Base cabinets produced in standard Advantage species.

- **Exposed Ends (EXP)** – Matching specie veneer on the exterior face of 1/2” thick plywood cabinet sides. The interior of plywood Exposed Ends will remain as White Birch.
- **Flush Ends (FL)** – Matching specie veneer on the exterior face of 3/4” thick plywood cabinet sides. The interior of plywood Flush Ends will remain as White Birch.
- **Flush Unexposed Ends (FUE)** – Natural Birch veneer on the exterior face of the 3/4” thick flush plywood cabinet sides. Designed to be utilized when extra support is desired from non-exposed flush end panels. The interior of the plywood Flush Unexposed Ends will remain as White Birch.
- **Matching Interior (MI)** – Matching specie veneer is available on all internal cabinet parts. The Matching Interior Option is not available in combination with the Solid Wood Shelf Upgrade Option.

Solid Wood Shelf Upgrade (WS) – The **Solid Wood Shelf Upgrade Option** replaces the standard White Birch plywood shelving with solid wood Natural Birch shelving. Solid Wood Shelving is 3/4” thick with a bullnosed front edge and finished with a UV topcoat. The Solid Wood Shelf Upgrade Option is not available in combination with the Matching Interior Option or when Base cabinets are deeper than 24”. Solid shelving available up to 18” deep.

Dust Top (DT) - The **Dust Top Option** replaces the front and back strips at the top of the Base cabinet with a 1/2” thick full depth Birch plywood top. The Dust Top is machined on the left and right sides to slide into the grooves near the top of the side panels, offering additional stability to the cabinet.

Extended Stiles (EXT) – The **Extended Stile Option** provides additional width on the left, right or both stiles of the front frame. Up to 3” of additional material provides clearance between the cabinet and adjacent walls or other cabinetry allowing cabinet doors and drawers to fully open without interference. Extended stiles also provide the opportunity to scribe the frame to the wall contours during the installation process.

Leg Extension (LE) – the **Leg Extension Option** can be added to the left, right or both stiles of the front frame. When selected, the Leg Extension Option omits the toe kick from the cabinet and extends the front frame stile(s) to the floor creating a closed end panel to the cabinet.

Prep for False Door Side (PFD) – The **Prep for False Door Side Option** maintains the overall front frame width ordered, but relocates the cabinet side panel, moving it inward by 13/16” for each Prep for False Door Side selected. This creates a 3/4” reveal behind the 1-1/2” wide front frame stile to accommodate the decorative door end panel. The Prep for False Door Side Option can be ordered for the left, right or both cabinet sides. All cabinet components are automatically resized accordingly when the Prep for False Door Side Option is selected.

Square Toe Kick Notch (STN) – Standard Base cabinet side panels have a 3-1/2” deep x 4” high toe kick notch with a 1/4” radius at the intersecting corner. This corner can be squared with the **Square Toe Notch Option** which makes the corner notch 90° to aid in toe board installation.

Flush Toe (FT) – When selected, the **Flush Toe Option** replaces the standard toe kick notch in both side panels with a 5-1/2” bottom rail on the front frame.

Shaped Bottom Rail (SBR) – The **Shaped Bottom Rail Option** automatically adds the Flush Toe to the cabinet’s front frame. The 5-1/2” wide bottom rail gives customers the choice of 6 decorative shapes on the bottom rail of the Flush Toe, providing a furniture type appearance.

Shaped Side (SS) – The **Shaped Side Option** provides a choice of 4 decorative shapes on the bottom of Exposed Ends or Flush Ends. Shaped Sides are available on left, right or both sides, but is not available in combination with Extended Stiles, Flushed Unexposed Ends or Loose Toe Platform.

Toe Space Side (TSS) – The **Toe Space Side Option** replaces the bottom 4” of the side panel with a recessed toe space on the left, right or both sides of most Base cabinetry. This option is commonly used on island or peninsula cabinet sides.

B/CSB - Base

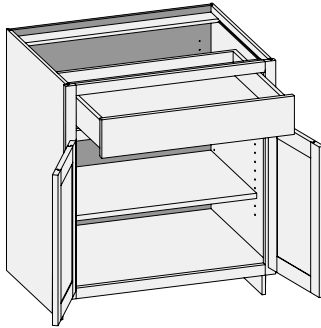

Custom Size Ranges
 Single Door Width: 12" – 24"
 Butt Door Width: 24" – 36"
 Height: 31-1/2" – 42"
 Depth: 12", 15", 18", 21", 24",
 27", 30"

- When height changes, lower opening height changes. Drawer opening height fixed at 5".
- Specify single or butt doors on custom size cabinets 24" wide.

24" Deep			
Single Door Cabinets		Butt Door Cabinets	
B1234.5	B2134.5	B2434.5BD	B3334.5BD
B1534.5	B2434.5	B2734.5BD	B3634.5BD
B1834.5		B3034.5BD	

B/CSB2D1D - Base Two Door One Drawer

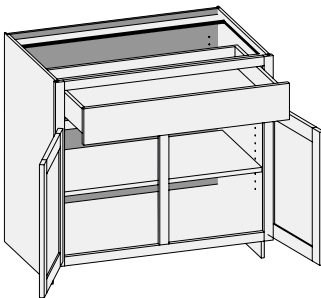

Custom Size Ranges
 Width: 27" – 36"
 Height: 31-1/2" – 42"
 Depth: 12", 15", 18", 21", 24",
 27", 30"

- When height changes, lower opening height changes. Drawer opening height fixed at 5".

24" Deep
B2734.5

B/CSBBD2D - Base Butt Door Two Drawer

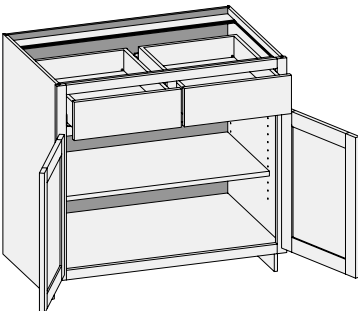

Custom Size Ranges
 Width: 30" – 36"
 Height: 31-1/2" – 42"
 Depth: 12", 15", 18", 21", 24",
 27", 30"

- When height changes, lower opening height changes. Drawer opening height fixed at 5".

24" Deep
B3034.5BD2D
B3334.5BD2D
B3634.5BD2D

B/CSB2D2D - Base Two Door Two Drawer

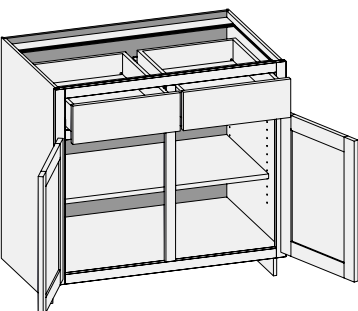

Custom Size Ranges
 Width: 30" – 48"
 Height: 31-1/2" – 42"
 Depth: 12", 15", 18", 21", 24",
 27", 30"

- When height changes, lower opening height changes. Drawer opening height fixed at 5".

24" Deep	
B3034.5	B4234.5
B3334.5	B4534.5
B3634.5	B4834.5
B3934.5	

Base Options Key: EXP = Exposed End(s) FL = Flush End(s) FUE = Flush Unexposed End(s) SS = Shaped Side PFD = Prep for False Door
 EXT = Extended Stile(s) FT = Flush Toe SBR = Shaped Bottom Rail LE = Leg Extension TSS = Toe Space Side OS = Omit Shelving
 NSH = No Shelf Holes WS = Solid Wood Shelves MI = Matching Interior DT = Dust Top PTB = Plywood Toe Backer

B/CSB3D3D - Base Three Door Three Drawer

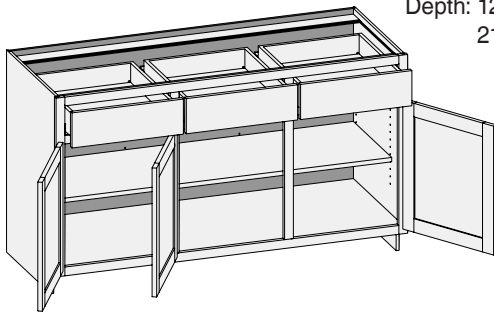

Custom Size Ranges
 Width: 48" – 72"
 Height: 31-1/2" – 42"
 Depth: 12", 15", 18",
 21", 24", 27", 30"

- Additional shelf holes are provided on cabinet back to support wide shelves.
- Doors hinged on center stile require 1/2" overlay hinges for 1-1/4" or 1-3/8" overlay.
- When height changes, lower opening height changes. Drawer opening height fixed at 5".
- Unavailable Option: WS.

24" Deep	
B5134.5	B6334.5
B5434.5	B6634.5
B5734.5	B6934.5
B6034.5	B7234.5

BTCP/CSBTCP - Base w/Trash Can Pull-Out

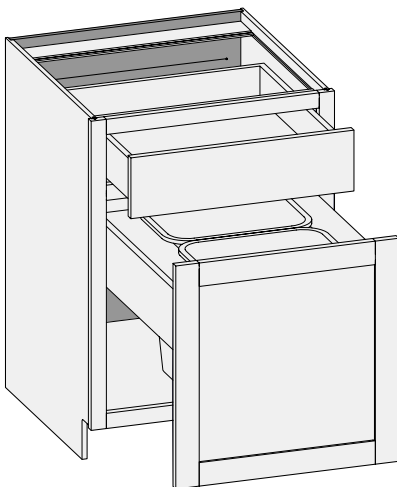

Custom Size Ranges
 Width: 18" – 27"
 Height: 31-1/2" – 34-1/2"
 Depth: 24"

- Cabinet depth is 24". Depth customization is not available due to Trash Can Pull-Out and hardware requirements.
- Trash Can Pull-Out unit is prefinished Natural Birch with a Hard Maple plywood top.
- Single can, double cans or units with no cut-outs are available.
- Pull-out unit is 6" high to accommodate door mounting.
- Units include 28 quart grey waste cans.
- Units 18" – 23-15/16" have one can; units 24" – 27" includes 2 cans. When ordering custom size cabinets within these ranges specify single can, double cans or no cut-outs.
- When cabinet height changes, lower opening height changes. Drawer opening height fixed at 5".
- Not available in inset applications.
- Unavailable Option: PFD.

24" Deep	
BTCP1834.5	BTCP2434.5
BTCP2134.5	BTCP2734.5

BPO/CSBPO Base Pull Out

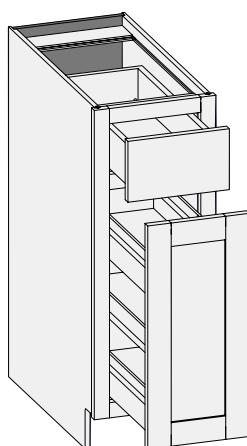

Custom Size Ranges
 Width: 9" and 12"
 Height: 34-1/2"
 Depth: 24"

- Cabinet depth is 24". Depth customization is not available due to pull-out and hardware requirements.
- Unit includes a fully assembled pull-out unit with full extension drawer slides and a mounting cleat for quick and easy installation.
- Pull-out is constructed from Natural Birch solids and plywood finished with a durable, clear UV topcoat and includes two fixed shelves and one adjustable shelf.
- Integrated 6-way adjustable door mounting hardware allows for easy installation for all overlays.
- Unavailable Option: SBR.

24" Deep	
BPO0934.5	BPO1234.5

Base Options Key: EXP = Exposed End(s) FL = Flush End(s) FUE = Flush Unexposed End(s) SS = Shaped Side PFD = Prep for False Door
 EXT = Extended Stile(s) FT = Flush Toe SBR = Shaped Bottom Rail LE = Leg Extension TSS = Toe Space Side OS = Omit Shelving
 NSH = No Shelf Holes WS = Solid Wood Shelves MI = Matching Interior DT = Dust Top PTB = Plywood Toe Backer

BS/CSBS - Base Sink w/Butt Doors

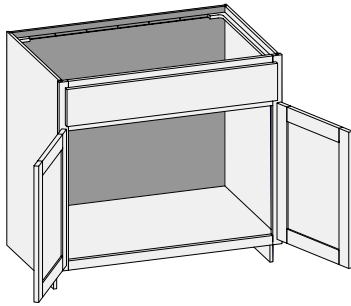

Custom Size Ranges
 Width: 24" – 36"
 Height: 31-1/2" – 42"
 Depth: 18" – 30"

- False drawer front.
- When height changes, lower opening height changes. Drawer opening height fixed at 5".
- Specify single or butt doors on custom size cabinets 24" wide.

24" Deep	
BS2434.5BD	BS3334.5BD
BS2734.5BD	BS3634.5BD
BS3034.5BD	

BS/CSBS2D1D - Base Sink Two Door One Drawer

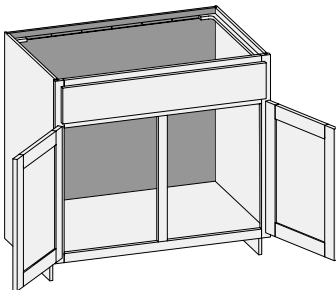

Custom Size Ranges
 Width: 27" – 36"
 Height: 31-1/2" – 42"
 Depth: 18" – 30"

- False drawer front.
- When height changes, lower opening height changes. Drawer opening height fixed at 5".

24" Deep
BS2734.5

BS/CSBS2D2D - Base Sink Two Door Two Drawer

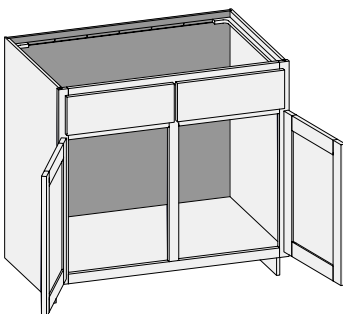

Custom Size Ranges
 Width: 30" – 48"
 Height: 31-1/2" – 42"
 Depth: 18" – 30"

- Two false drawer fronts.
- When height changes, lower opening height changes. Drawer opening height fixed at 5".

24" Deep	
BS3034.5	BS4234.5
BS3334.5	BS4534.5
BS3634.5	BS4834.5
BS3934.5	

Base Options Key: EXP = Exposed End(s) FL = Flush End(s) FUE = Flush Unexposed End(s) SS = Shaped Side PFD = Prep for False Door
 EXT = Extended Stile(s) FT = Flush Toe SBR = Shaped Bottom Rail LE = Leg Extension TSS = Toe Space Side OS = Omit Shelving
 NSH = No Shelf Holes WS = Solid Wood Shelves MI = Matching Interior DT = Dust Top PTB = Plywood Toe Backer

ASB/CSASB - Apron Sink Base w/Butt Doors

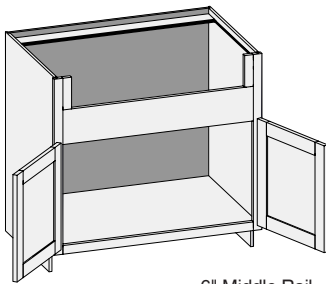

6" Middle Rail

Custom Size Ranges
Width: 24" – 36"
Height: 31-1/2" – 42"
Depth: 18" – 30"

- Sink bowl opening is 5-1/2" high, width is 6" less than cabinet width.
- Sink opening is trimmable to 4-1/2" in height and 3" in width.
- When height changes, lower opening height changes.
- Specify single or butt doors on custom size cabinets 24" wide.

24" Deep	
ASB2434.5BD	ASB3334.5BD
ASB2734.5BD	ASB3634.5BD
ASB3034.5BD	

ASB/CSASBCS - Apron Sink Base w/Center Stile

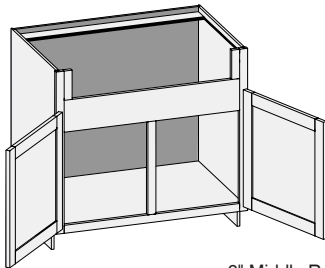

6" Middle Rail

Custom Size Ranges
Width: 27" – 48"
Height: 31-1/2" – 42"
Depth: 18" – 30"

- Sink bowl opening is 5-1/2" high, width is 6" less than cabinet width.
- Sink opening is trimmable to 4-1/2" in height and 3" in width.
- When height changes, lower opening height changes.

24" Deep	
ASB2734.5	ASB3934.5
ASB3034.5	ASB4234.5
ASB3334.5	ASB4534.5
ASB3634.5	ASB4834.5

BSFD/CSBSFD - Base Sink Full Door w/Butt Doors

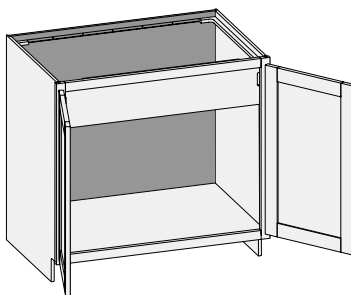

Custom Size Ranges
Width: 24" – 36"
Height: 31-1/2" – 34-1/2"
Depth: 18" – 30"

- 6-3/4" high apron conceals sink bowl, accommodates hinges and matches cabinet interior.
- Specify single or butt doors on custom size cabinets 24" wide.

24" Deep	
BSFD2434.5BD	BSFD3334.5BD
BSFD2734.5BD	BSFD3634.5BD
BSFD3034.5BD	

Base Options Key: EXP = Exposed End(s) FL = Flush End(s) FUE = Flush Unexposed End(s) SS = Shaped Side PFD = Prep for False Door
EXT = Extended Stile(s) FT = Flush Toe SBR = Shaped Bottom Rail LE = Leg Extension TSS = Toe Space Side OS = Omit Shelving
NSH = No Shelf Holes WS = Solid Wood Shelves MI = Matching Interior DT = Dust Top PTB = Plywood Toe Backer

BFD/CSBFD - Base Full Door

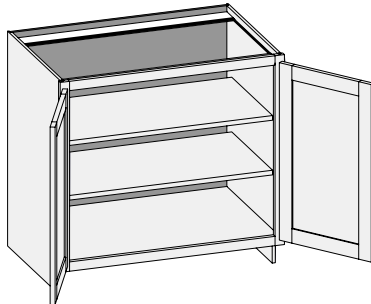

Custom Size Ranges
 Single Door Width: 9" – 24"
 Butt Door Width: 24" – 36"
 Height: 10" – 48"
 Depth: 5-1/2" – 30"

- BFD0934.5 does not include shelves.
- 10" – 22" high has no shelves.
- 22-1/16" – 28" high has one shelf.
- 28-1/16" – 40" high has two shelves.
- 40-1/16" – 48" high has three shelves.
- Specify single or butt doors on custom size cabinets 24" wide.

Single Door Cabinets – 24" Deep		Butt Door Cabinets – 24" Deep	
BFD0934.5	BFD1834.5	BFD2434.5BD	BFD3334.5BD
BFD1234.5	BFD2134.5	BFD2734.5BD	BFD3634.5BD
BFD1534.5	BFD2434.5	BFD3034.5BD	

Single Door Cabinets – 12-1/2" Deep		Butt Door Cabinets – 12-1/2" Deep	
BWD1234.5	BWD2134.5	BWD2434.5BD	BWD3334.5BD
BWD1534.5	BWD2434.5	BWD2734.5BD	BWD3634.5BD
BWD1834.5		BWD3034.5BD	

BFD/CSBFD2CS - Base Full Door w/Center Stile

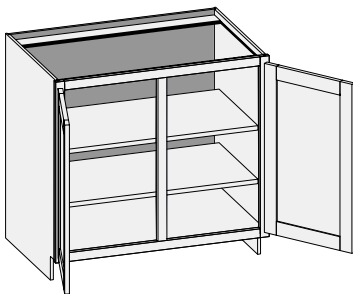

Custom Size Ranges
 Width: 27" – 48"
 Height: 10" – 48"
 Depth: 5-1/2" – 30"

- 10" – 22" high has no shelves.
- 22-1/16" – 28" high has one shelf.
- 28-1/16" – 40" high has two shelves.
- 40-1/16" – 48" high has three shelves.

24" Deep		12-1/2" Deep	
BFD2734.5	BFD3934.5	BWD2734.5	BWD3934.5
BFD3034.5	BFD4234.5	BWD3034.5	BWD4234.5
BFD3334.5	BFD4534.5	BWD3334.5	BWD4534.5
BFD3634.5	BFD4834.5	BWD3634.5	BWD4834.5

BFD/CSBFD2CS - Base Full Door w/Two Center Stiles

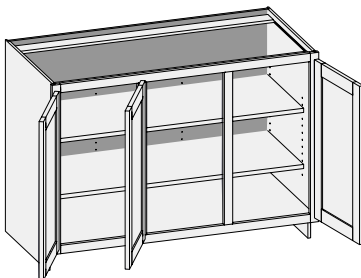

Custom Size Ranges
 Width: 48" – 72"
 Height: 10" – 42"
 Depth: 5-1/2" – 30"

- Additional shelf holes are provided on cabinet back to support wide shelves.
- Doors hinged on center stile require 1/2" overlay hinges for 1-1/4" or 1-3/8" overlay.
- 10" – 22" high has no shelves.
- 22-1/16" – 28" high has one shelf.
- 28-1/16" – 40" high has two shelves.
- 40-1/16" – 48" high has three shelves.
- Unavailable Option: WS.

24" Deep	
BFD5134.5	BFD6334.5
BFD5434.5	BFD6634.5
BFD5734.5	BFD6934.5
BFD6034.5	BFD7234.5

Base Options Key: EXP = Exposed End(s) FL = Flush End(s) FUE = Flush Unexposed End(s) SS = Shaped Side PFD = Prep for False Door
 EXT = Extended Stile(s) FT = Flush Toe SBR = Shaped Bottom Rail LE = Leg Extension TSS = Toe Space Side OS = Omit Shelving
 NSH = No Shelf Holes WS = Solid Wood Shelves MI = Matching Interior DT = Dust Top PTB = Plywood Toe Backer

BFDRO/CSBFDRO - Base Full Door Roll-Out

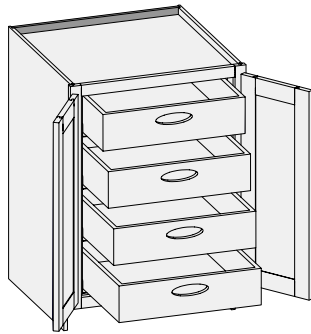

Custom Size Ranges
 Single Door Width: 12" – 24"
 Butt Door Width: 24" – 36"
 Height: 31-1/2" – 34-1/2"
 Depth: 12", 15", 18",
 21", 24", 27", 30"

- Units are configured with four 5" high drawer boxes. Interior panels are pre-drilled for drawer slide placement and installation.
- Roll-out drawers include hand pulls. Specify Standard, Circle or Ellipse (shown) pull.
- Specify single or butt doors on custom size cabinets 24" wide.

Single Door Cabinets – 24" Deep		Butt Door Cabinets – 24" Deep	
BFDRO1234.5	BFDRO2134.5	BFDRO2434.5BD	BFDRO3334.5BD
BFDRO1534.5	BFDRO2434.5	BFDRO2734.5BD	BFDRO3634.5BD
BFDRO1834.5		BFDRO3034.5BD	

BFDROI/CSBFDROI - Base Full Door Roll-Out Inset

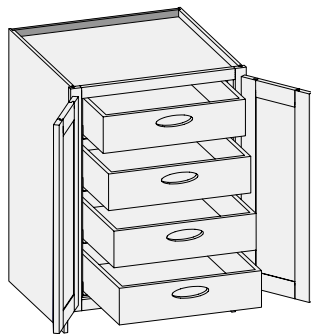

Custom Size Ranges
 Single Door Width: 15" – 24"
 Butt Door Width: 24" – 36"
 Height: 31-1/2" – 34-1/2"
 Depth: 12", 15", 18",
 21", 24", 27", 30"

- Specifically designed for inset application.
- Units are configured with four 5" high drawer boxes. Interior panels are pre-drilled for drawer slide placement and installation.
- Drawer slides are 3" less than the depth of the cabinet to accommodate inset doors and hardware.
- Roll-out drawers include hand pulls. Specify Standard, Circle or Ellipse (shown) pull.
- Specify single or butt doors on custom size cabinets 24" wide.

Single Door Cabinets – 24" Deep		Butt Door Cabinets – 24" Deep	
BFDROI1534.5	BFDROI2134.5	BFDROI2434.5BD	BFDROI3334.5BD
BFDROI1834.5	BFDROI2434.5	BFDROI2734.5BD	BFDROI3634.5BD
		BFDROI3034.5BD	

BFDP0/CSBFDPO Base Full Door Pull Out

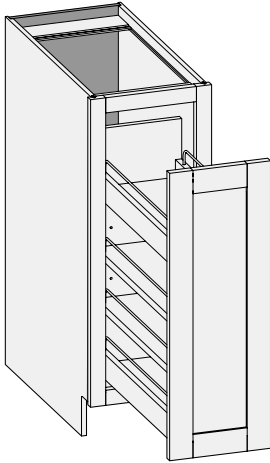

Custom Size Ranges
 Width: 9", 12", 15"
 and 18"
 Height: 34-1/2"
 Depth: 24"

- Cabinet depth is 24". Depth customization is not available due to pull-out and hardware requirements.
- Unit includes a fully assembled pull-out that includes full extension drawer slides and a mounting cleat for quick and easy installation.
- Pull-out is constructed from Natural Birch solids and plywood finished with a durable, clear UV topcoat and includes two fixed shelves and two adjustable shelves.
- Integrated 6-way adjustable door mounting hardware allows for easy installation for all overlays.
- Unavailable Option: WS.

24" Deep			
BFDP00934.5	BFDP01234.5	BFDP01534.5	BFDP01834.5

BFDTD/CSBFTD Base Full Door Tray Divider

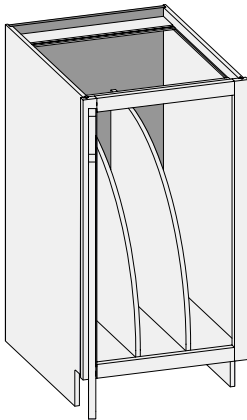

Custom Size Ranges
 Width: 9" - 18"
 Height: 34-1/2"
 Depth: 24"

- Cabinet depth is 24". Depth customization and inset doors and drawer fronts are not available due to tray divider design and installation requirements.
- Dividers are constructed from 1/2" Natural Birch UV topcoat plywood with an edgebanded front edge.
- Cabinet floor is dovetailed and back includes pilot holes to install dividers.
- Units 9" - 12" have 1 divider centered; units 12-1/16" - 18" have 2 dividers. As cabinet width increases, space between dividers increases equally.
- Unavailable Option: WS.

Not available prefit: Overlay only

24" Deep			
BFDTD0934.5	BFDTD1234.5	BFDTD1534.5	BFDTD1834.5

CSB1D - Base One Drawer

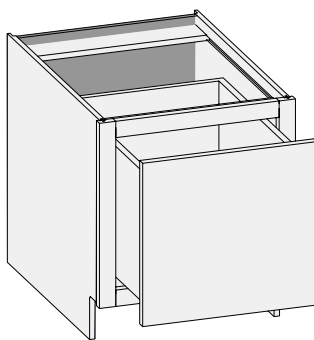

Custom Size Ranges
 Width: 12" - 36"
 Height: 12" - 21"
 Depth: 12", 15", 18",
 21", 24", 27",
 30"

- When height changes, drawer box height changes proportionately.

Base Options Key: EXP = Exposed End(s) FL = Flush End(s) FUE = Flush Unexposed End(s) SS = Shaped Side PFD = Prep for False Door
 EXT = Extended Stile(s) FT = Flush Toe SBR = Shaped Bottom Rail LE = Leg Extension TSS = Toe Space Side OS = Omit Shelving
 NSH = No Shelf Holes WS = Solid Wood Shelves MI = Matching Interior DT = Dust Top PTB = Plywood Toe Backer

CSB1DCS - Base One Drawer w/Center Stile

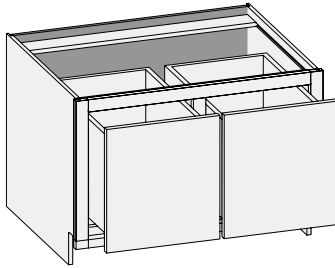

Custom Size Ranges
 Width: 30" – 48"
 Height: 12" – 21"
 Depth: 12", 15", 18",
 21", 24", 27", 30"

- When height changes, drawer box height changes proportionately.

CSB1D2CS - Base One Drawer w/ 2 Center Stiles

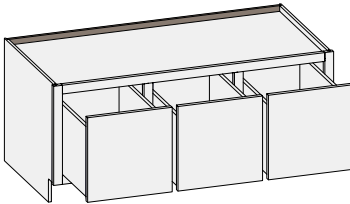

Custom Size Ranges
 Width: 36" – 96"
 Height: 12" – 21"
 Depth: 12", 15", 18",
 21", 24", 27", 30"

- When height changes, drawer box height changes proportionately.
- The width of the drawer fronts are equal. Front frame opening widths are adjusted accordingly based on selected door overlay to maintain published reveals.

B2D/CSB2D - Base Two Drawer

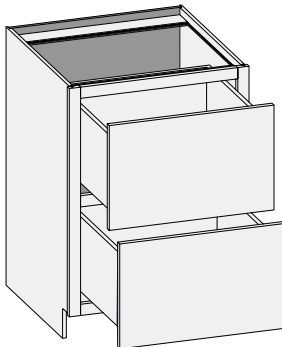

Custom Size Ranges
 Width: 12" – 39"
 Height: 31-1/2" – 34-1/2"
 Depth: 12", 15", 18", 21",
 24", 27", 30"

- When height changes, both drawer heights are equal.

24" Deep	
B2D1234.5	B2D2734.5
B2D1534.5	B2D3034.5
B2D1834.5	B2D3334.5
B2D2134.5	B2D3634.5
B2D2434.5	B2D3934.5

B2DRO/CSB2DRO - Base Two Drawer Roll-Out

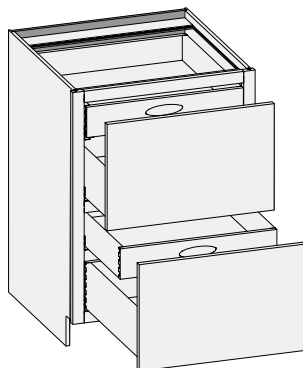

Custom Size Ranges
 Width: 12" – 39"
 Height: 31-1/2" – 34-1/2"
 Depth: 12", 15", 18", 21",
 24", 27", 30"

- Units are configured with 4" high roll-out drawers over 6" high conventional drawer box in each opening.
- Roll-out drawers include hand pulls. Specify Standard, Circle or Ellipse (shown) pull.
- When height changes, both drawer heights are equal.

24" Deep	
B2DRO1234.5	B2DRO2734.5
B2DRO1534.5	B2DRO3034.5
B2DRO1834.5	B2DRO3334.5
B2DRO2134.5	B2DRO3634.5
B2DRO2434.5	B2DRO3934.5

Base Options Key: EXP = Exposed End(s) FL = Flush End(s) FUE = Flush Unexposed End(s) SS = Shaped Side PFD = Prep for False Door
 EXT = Extended Stile(s) FT = Flush Toe SBR = Shaped Bottom Rail LE = Leg Extension TSS = Toe Space Side OS = Omit Shelving
 NSH = No Shelf Holes WS = Solid Wood Shelves MI = Matching Interior DT = Dust Top PTB = Plywood Toe Backer

B3D/CSB3D - Base Three Drawer

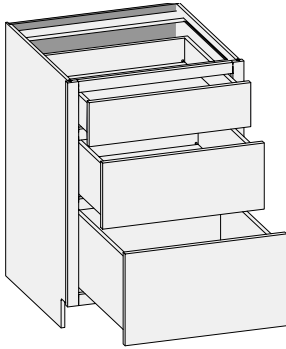

Custom Size Ranges
 Width: 12" – 39"
 Height: 31-1/2" – 34-1/2"
 Depth: 12", 15", 18", 21",
 24", 27", 30"

- When height changes, lower opening height changes. Upper and middle opening heights fixed at 5" and 8".

24" Deep	
B3D1234.5	B3D2734.5
B3D1534.5	B3D3034.5
B3D1834.5	B3D3334.5
B3D2134.5	B3D3634.5
B3D2434.5	B3D3934.5

B3DEH/CSB3DEH - Base Three Drawer w/Two Equal Height Lower Drawers

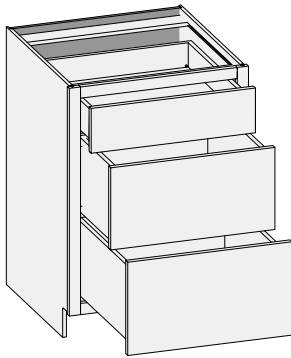

Custom Size Ranges
 Width: 12" – 39"
 Height: 31-1/2" – 34-1/2"
 Depth: 12", 15", 18",
 21", 24", 27", 30"

- When height changes, both lower opening heights change. Upper opening height fixed at 5".
- Lower drawer front heights are equal.

24" Deep	
B3DEH1234.5	B3DEH2734.5
B3DEH1534.5	B3DEH3034.5
B3DEH1834.5	B3DEH3334.5
B3DEH2134.5	B3DEH3634.5
B3DEH2434.5	B3DEH3934.5

7

Advantage Base Cabinets

B4D/CSB4D - Base Four Drawer

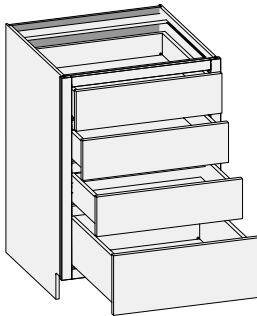

Custom Size Ranges
 Width: 12" – 39"
 Height: 31-1/2" – 34-1/2"
 Depth: 12", 15", 18", 21",
 24", 27", 30"

- When height changes, lower opening height changes. Upper opening height fixed at 5".
- Top 3 drawer front heights are equal.

24" Deep	
B4D1234.5	B4D2134.5
B4D1534.5	B4D2434.5
B4D1834.5	B4D2734.5

B4D2S2EH/CSB4D2S2EH - Base Four Drawer w/Two Side by Side Equal Height Lower Drawers

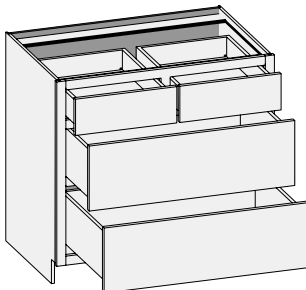

Custom Size Ranges
 Width: 30" – 39"
 Height: 31-1/2" – 34-1/2"
 Depth: 12", 15", 18",
 21", 24", 27", 30"

- When height changes, both lower opening heights change. Upper opening height fixed at 5".
- Lower drawer front heights are equal.

24" Deep	
B4D2S2EH3034.5	B4D2S2EH3634.5
B4D2S2EH3334.5	B4D2S2EH3934.5

Base Options Key: EXP = Exposed End(s) FL = Flush End(s) FUE = Flush Unexposed End(s) SS = Shaped Side PFD = Prep for False Door
 EXT = Extended Stile(s) FT = Flush Toe SBR = Shaped Bottom Rail LE = Leg Extension TSS = Toe Space Side OS = Omit Shelving
 NSH = No Shelf Holes WS = Solid Wood Shelves MI = Matching Interior DT = Dust Top PTB = Plywood Toe Backer

BCFD/CSBCFD - Base Corner Full Door

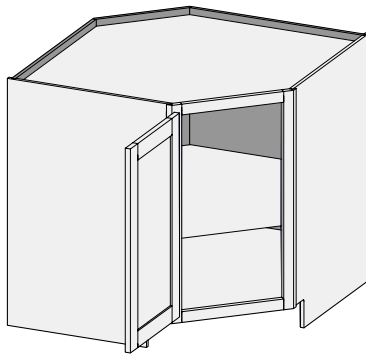

17" Face
18-3/32" Frame Width

Custom Size Ranges
Width: 36"
Height: 31-1/2" – 42"
Depth: 36"

- Shelf standard.
- Shelf mounted wood susan shelves are available. See Section 11 – Accessories.
- Minimum entry opening width required is 35" (doorways, hallways, etc.).
- When ordered in 1-1/4" and 1-3/8" overlay applications (with or without hinges), cabinets will have their door sized as 1/2" overlay in width only to ensure adequate clearance.
- Use filler or extended stiles accordingly.
- Unavailable Options: SS, PFD, EXT, LE, TSS, WS.

24" Deep Side

BCFD3634.5

BCFDLS - Base Corner Full Door w/ Lazy Susan

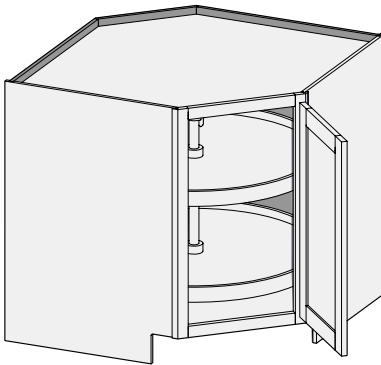

17" Face
18-3/32" Frame Width

Custom Size Ranges
Width: 36"
Height: 34-1/2"
Depth: 36"

- Cabinet top and bottom are pre-drilled to accept hub assembly.
- Cabinet includes 32" diameter entry level plastic susan with two independently rotating shelves mounted on a center pole.
- White susan shelves feature a self-lubricating nylon bearing and tool-free height adjustment.
- Size customization is not available due to susan size constraints.
- Minimum entry opening width required is 35" (doorways, hallways, etc.).
- When ordered in 1-1/4" and 1-3/8" overlay applications (with or without hinges), cabinets will have their door sized as 1/2" overlay in width only to ensure clearance.
- Not available with inset applications.
- Unavailable Options: SS, PFD, EXT, LE, TSS.

24" Deep Side

BCFDLS 3634.5

BSC/CSBSC - Base Sink Corner

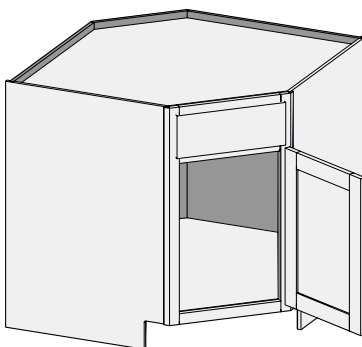

17" Face
18-3/32" Frame Width

Custom Size Ranges
Width: 36"
Height: 31-1/2" – 42"
Depth: 36"

- False drawer front.
- Minimum entry opening width required is 35" (doorways, hallways, etc.).
- When ordered in 1-1/4" and 1-3/8" overlay applications (with or without hinges), cabinets will have their door sized as 1/2" overlay in width only to ensure adequate clearance.
- Unavailable Options: SS, PFD, EXT, LE, TSS.

24" Deep Side

BSC3634.5

Base Options Key: EXP = Exposed End(s) FL = Flush End(s) FUE = Flush Unexposed End(s) SS = Shaped Side PFD = Prep for False Door
EXT = Extended Stile(s) FT = Flush Toe SBR = Shaped Bottom Rail LE = Leg Extension TSS = Toe Space Side OS = Omit Shelving
NSH = No Shelf Holes WS = Solid Wood Shelves MI = Matching Interior DT = Dust Top PTB = Plywood Toe Backer

BCP/CSBCP – Base Corner Pie Cut

Custom Size Ranges
 Width: 33" – 42"
 Height: 31-1/2" – 42"
 Depth: 33" – 42"

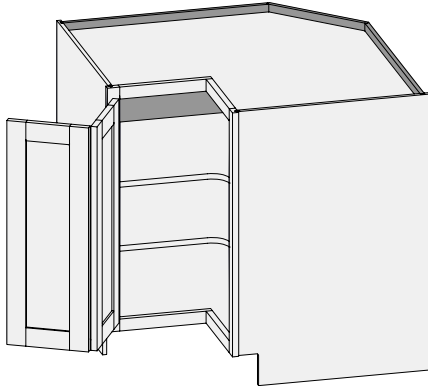

- Plywood shelf standard; wood shelf upgrade available on BCP3634.5 only.
- Shelf mounted wood susan shelves are available. See Section 11 – Accessories.
- CSBCP available with custom size legs. Specified width (left dimension) and depth (right dimension). Side dimension remains fixed; front frame pie cut opening adjusts as size changes.
- Minimum entry opening width required for BCP3634.5 is 35" (doorways, hallways etc.).
- When hinges are ordered in 1-1/4" and 1-3/8" overlay applications, cabinets will have their door sized as 1/2" overlay in width only.
- If hinges are not specified, 1-1/4" and 1-3/8" overlay sizing rules apply. These overlays require adequate clearance for door functionality between corner and adjacent cabinets. Use filler or extended stiles accordingly.
- Optional Soss hinges available.
- Unavailable Options: SS, PFD, EXT, LE, TSS, WS.

24" Deep Side
BCP3334.5
BCP3634.5

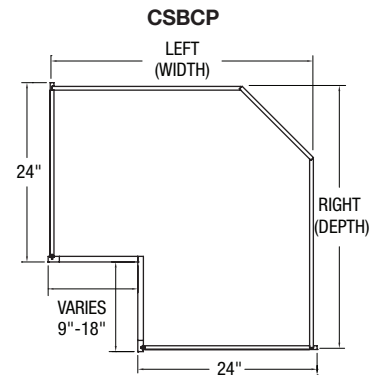
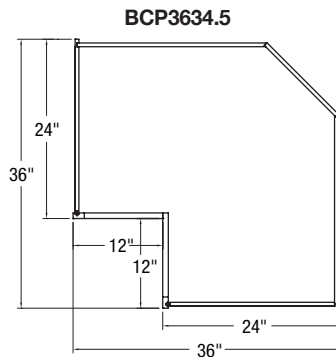
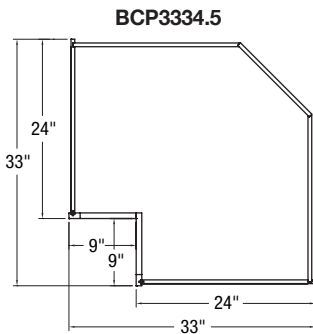

Base Options Key: EXP = Exposed End(s) FL = Flush End(s) FUE = Flush Unexposed End(s) SS = Shaped Side PFD = Prep for False Door
 EXT = Extended Stile(s) FT = Flush Toe SBR = Shaped Bottom Rail LE = Leg Extension TSS = Toe Space Side OS = Omit Shelving
 NSH = No Shelf Holes WS = Solid Wood Shelves MI = Matching Interior DT = Dust Top PTB = Plywood Toe Backer

BCPLS – Base Corner Pie Cut Lazy Susan

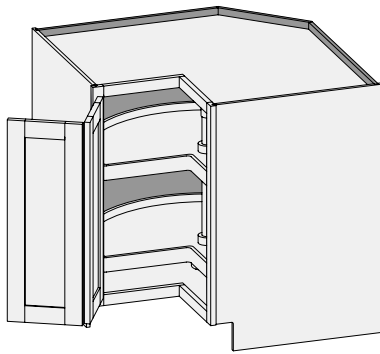

Custom Size Ranges
Width: 36"
Height: 34-1/2"
Depth: 36"

- Cabinet top and bottom is pre-drilled to accept hub assembly.
- Cabinet includes 32" diameter entry level plastic susan with two independently rotating kidney shelves mounted on a center pole.
- White susan shelves feature a self-lubricating nylon bearing and tool-free height adjustment.
- Height customization is not available due to susan size constraints.
- Minimum entry opening width required is 35" (doorways, hallways, etc.).
- When hinges are ordered in 1-1/4" and 1-3/8" overlay applications, cabinets will have their door sized as 1/2" overlay in width only.
- If hinges are not specified, 1-1/4" and 1-3/8" overlay sizing rules apply. These overlays require adequate clearance for door functionality between corner and adjacent cabinets. Use filler or extended stiles accordingly.
- Not available with inset applications.
- Optional Soss hinges available.
- Unavailable Options: SS, PFD, EXT, LE, TSS, WS.

BCPLS3634.5

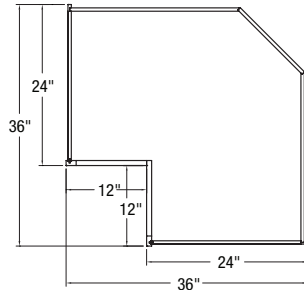

24" Deep Side

BCPLS3634.5

BCP3D/CSBCP3D – Base Corner Pie Cut Three Drawer

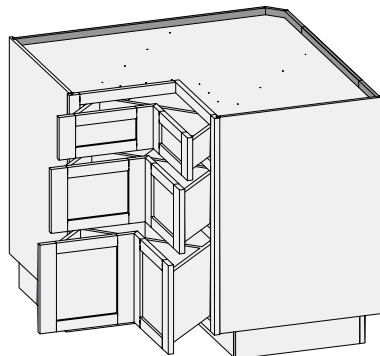

Custom Size Ranges
Width: 39", 42"
Height: 31-1/2" – 34-1/2"
Depth: 39", 42"

- 1-1/4" and 1-3/8" overlay applications will have their drawer fronts sized as 1/2" overlay in width only.
- Not available with inset applications.
- Not available with miter drawer front.
- Cabinet includes corner drawer boxes with back extensions.
- Each drawer front comes as two separate pieces using edge profile L-151 (45 degrees) standard to form the mitered inside corner.
- 5-piece drawer fronts, one stile on each will be 3/4" wider on the mitered edge to form the inside corner. Wide framing upcharges will apply.
- Exterior edge profiles can be specified to match adjacent cabinetry.
- Customizable in height only.
- When height changes, lower opening height changes. Upper and middle opening heights fixed at 5" and 8".
- Separate 4" high toe platform is standard to aid in passing through doorways.
- Minimum entry opening with width required is 35" (doorways, hallways, etc.).
- Unavailable Options: SS, PFD, EXT, LE, TSS, WS.

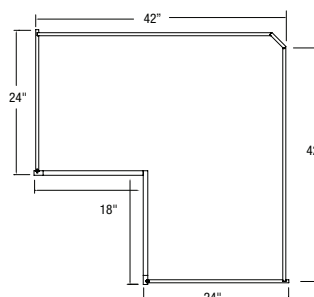
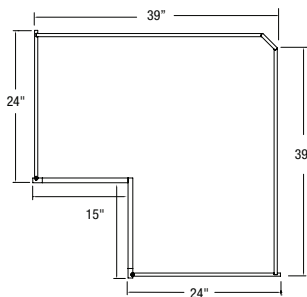

24" Deep Side

BCP3D3934.5

BCP3D4234.5

Base Options Key: EXP = Exposed End(s) FL = Flush End(s) FUE = Flush Unexposed End(s) SS = Shaped Side PFD = Prep for False Door
EXT = Extended Stile(s) FT = Flush Toe SBR = Shaped Bottom Rail LE = Leg Extension TSS = Toe Space Side OS = Omit Shelving
NSH = No Shelf Holes WS = Solid Wood Shelves MI = Matching Interior DT = Dust Top PTB = Plywood Toe Backer

BBCR/CSBBCR – Base Blind Cabinet Blind Right

Custom Size Ranges
 Width: 36" – 48"
 Height: 31-1/2" - 42"
 Depth: 12", 15", 18", 21", 24",
 27", 30"
 Functional opening: 12" – 21"

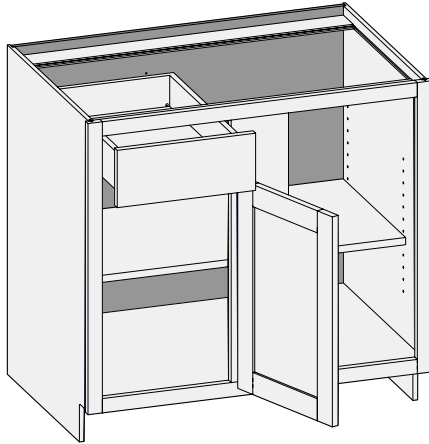

6" Center Stile

- Overall cabinet size is the actual width specified.
- Blind section is on the right.
- Specify functional opening width between 12" and 21".
- Door is always hinged on center stile for all overlays.
- When height changes, lower opening height changes. Drawer height fixed at 5".
- 1-1/4" and 1-3/8" overlay use 1/2" overlay hinges.
- Door height and adjacent reveal will follow overlay specified.
- Minimum exposed blind amount for all overlays is 2-1/2" to ensure adequate clearance for adjacent door and drawer function.
- Excessive hardware projection may require a greater amount of exposed blind. Design and install accordingly.
- Unavailable Options: SS and TSS.

24" Deep	
BBCR3634.5	BBCR4534.5
BBCR3934.5	BBCR4834.5
BBCR4234.5	

BBCL/CSBBCL – Base Blind Cabinet Blind Left

Custom Size Ranges
 Width: 36" – 48"
 Height: 31-1/2" - 42"
 Depth: 12", 15", 18", 21", 24",
 27", 30"
 Functional opening: 12" – 21"

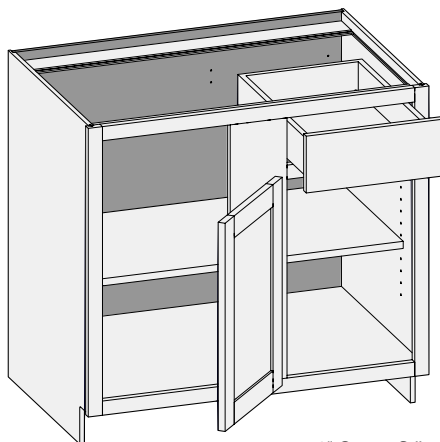

6" Center Stile

- Overall cabinet size is the actual width specified.
- Blind section is on the left.
- Specify functional opening width between 12" and 21".
- Door is always hinged on center stile for all overlays.
- When height changes, lower opening height changes. Drawer height fixed at 5".
- 1-1/4" and 1-3/8" overlay use 1/2" overlay hinges.
- Door height and adjacent reveal will follow overlay specified.
- Minimum exposed blind amount for all overlays is 2-1/2" to ensure adequate clearance for adjacent door and drawer function.
- Excessive hardware projection may require a greater amount of exposed blind. Design and install accordingly.
- Unavailable Options: SS and TSS.

24" Deep	
BBCL3634.5	BBCL4534.5
BBCL3934.5	BBCL4834.5
BBCL4234.5	

Base Options Key: EXP = Exposed End(s) FL = Flush End(s) FUE = Flush Unexposed End(s) SS = Shaped Side PFD = Prep for False Door
 EXT = Extended Stile(s) FT = Flush Toe SBR = Shaped Bottom Rail LE = Leg Extension TSS = Toe Space Side OS = Omit Shelving
 NSH = No Shelf Holes WS = Solid Wood Shelves MI = Matching Interior DT = Dust Top PTB = Plywood Toe Backer

BFDBCR/CSBFDBCR – Base Full Door Blind Cabinet Blind Right

Custom Size Ranges
 Width: 36" – 48"
 Height: 31-1/2" - 42"
 Depth: 12" – 30"
 Functional opening: 12" – 21"

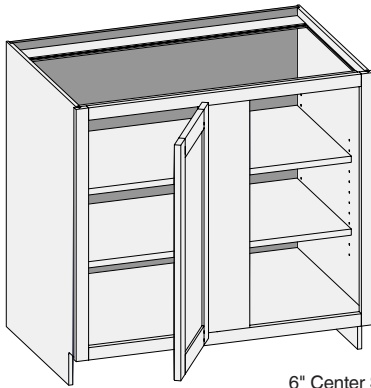

6" Center Stile

- Overall cabinet size is the actual width specified.
- Blind section is on the right.
- Specify functional opening width between 12" and 21".
- Door is always hinged on center stile for all overlays.
- 1-1/4" and 1-3/8" overlay use 1/2" overlay hinges.
- Door height and adjacent reveal will follow overlay specified.
- Minimum exposed blind amount for all overlays is 2-1/2" to ensure adequate clearance for adjacent door and drawer function.
- Excessive hardware projection may require a greater amount of exposed blind. Design and install accordingly.
- Unavailable Options: SS and TSS.

24" Deep	
BFDBCR3634.5	BFDBCR4534.5
BFDBCR3934.5	BFDBCR4834.5
BFDBCR4234.5	

BFDBCL/CSBFDBCL – Base Full Door Blind Cabinet Blind Left

Custom Size Ranges
 Width: 36" – 48"
 Height: 31-1/2" - 42"
 Depth: 12" – 30"
 Functional opening: 12" – 21"

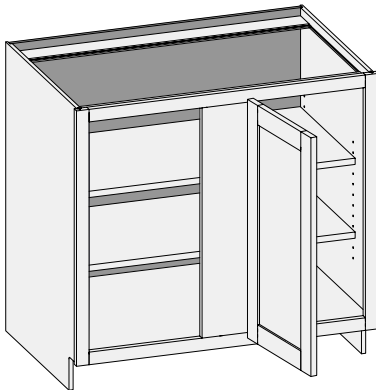

6" Center Stile

- Overall cabinet size is the actual width specified.
- Blind section is on the left.
- Specify functional opening width between 12" and 21".
- Door is always hinged on center stile for all overlays.
- 1-1/4" and 1-3/8" overlay use 1/2" overlay hinges.
- Door height and adjacent reveal will follow overlay specified.
- Minimum exposed blind amount for all overlays is 2-1/2" to ensure adequate clearance for adjacent door and drawer function.
- Excessive hardware projection may require a greater amount of exposed blind. Design and install accordingly.
- Unavailable Options: SS and TSS.

24" Deep	
BFDBCL3634.5	BFDBCL4534.5
BFDBCL3934.5	BFDBCL4834.5
BFDBCL4234.5	

Base Options Key: EXP = Exposed End(s) FL = Flush End(s) FUE = Flush Unexposed End(s) SS = Shaped Side PFD = Prep for False Door
 EXT = Extended Stile(s) FT = Flush Toe SBR = Shaped Bottom Rail LE = Leg Extension TSS = Toe Space Side OS = Omit Shelving
 NSH = No Shelf Holes WS = Solid Wood Shelves MI = Matching Interior DT = Dust Top PTB = Plywood Toe Backer

BCT/CSBCT - Base Cook Top w/Butt Doors

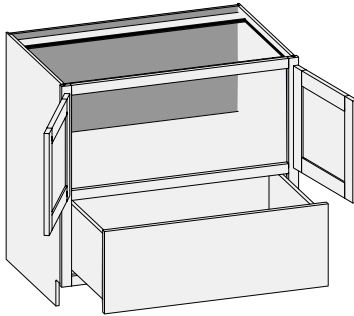

Custom Size Ranges
 Width: 30" – 42"
 Height: 31-1/2" – 42"
 Depth: 12", 15", 18",
 21", 24", 27", 30"

- When height changes, upper opening height changes, lower opening height fixed at 11-1/2".

24" Deep	
BCT3034.5BD	BCT3934.5BD
BCT3334.5BD	BCT4234.5BD
BCT3634.5BD	

CSBCT2D - Base Cook Top Two Drawer

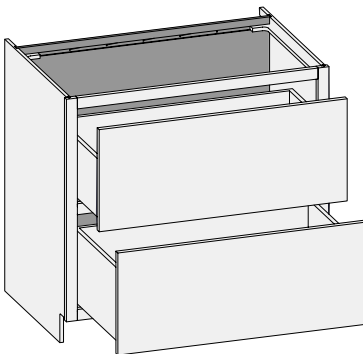

Custom Size Ranges
 Width: 36" – 48"
 Height: 34-1/2"
 Depth: 24", 27", 30"

- Designed for countertop mounted professional-style cooktops (non-downdraft ventilation units).
- Cabinet back recessed 3" to accommodate and conceal supply lines. Drawer box depth is 3" less due to the recessed back.
- Top drawer box is 8" high to accommodate appliance housing. Bottom drawer box is 10" high.

7

Advantage Base Cabinets

BR3D/CSBR3D - Base Range Three Drawer

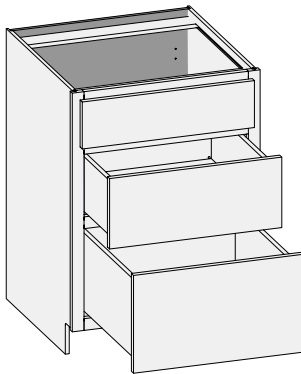

Custom Size Ranges
 Width: 30" – 39"
 Height: 31-1/2" – 34-1/2"
 Depth: 12", 15", 18",
 21", 24", 27", 30"

- False top drawer front.
- When height changes, lower opening height changes. Upper drawer and middle opening heights fixed at 5" and 8".

24" Deep	
BR3D3034.5	
BR3D3634.5	

Base Options Key: EXP = Exposed End(s) FL = Flush End(s) FUE = Flush Unexposed End(s) SS = Shaped Side PFD = Prep for False Door
 EXT = Extended Stile(s) FT = Flush Toe SBR = Shaped Bottom Rail LE = Leg Extension TSS = Toe Space Side OS = Omit Shelving
 NSH = No Shelf Holes WS = Solid Wood Shelves MI = Matching Interior DT = Dust Top PTB = Plywood Toe Backer

CSBCT4D - Base Cook Top Four Drawer

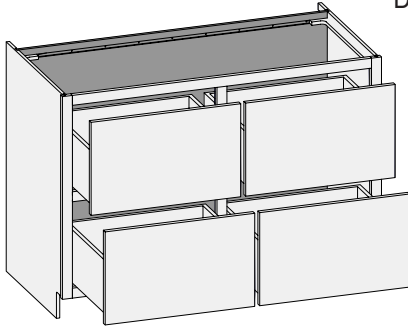

Custom Size Ranges
 Width: 36" – 60"
 Height: 34-1/2"
 Depth: 24", 27", 30"

- Designed for countertop mounted professional-style cooktops (non-downdraft ventilation units).
- When cabinet width changes, drawer front widths remain equal.
- Cabinet back recessed 3" to accommodate and conceal supply lines. Drawer box depth is 3" less due to the recessed back.
- Top drawer box is 8" high to accommodate appliance housing. Bottom drawer box is 10" high.

BRT2D/CSBRT2D - Base Range Top Two Drawer

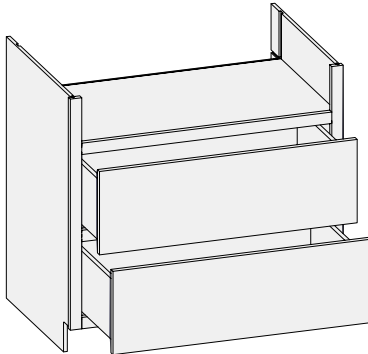

Custom Size Ranges
 Width: 36" – 48"
 Height: 34-1/2"
 Depth: 24", 27", 30"

- Designed for professional-style cooktop units.
- 6" high standard opening includes full floor to support appliance. Opening height is customizable from 5" to 8" in 1/16" increments.
- Cabinet back recessed 3" to accommodate and conceal supply lines. Drawer box depth is 3" less due to the recessed back.
- Both drawer boxes are 8" high.

24" Deep	
BRT2D3634.5	BRT2D4534.5
BRT2D3934.5	BRT2D4834.5
BRT2D4234.5	

CSBRT4D - Base Range Top Four Drawer

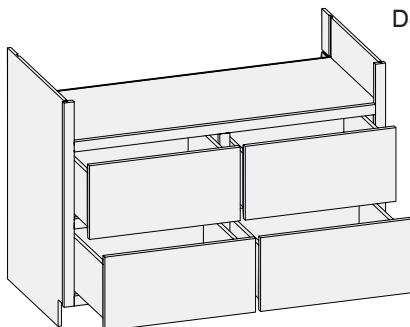

Custom Size Ranges
 Width: 36" – 60"
 Height: 34-1/2"
 Depth: 24", 27", 30"

- Designed for professional-style cooktop units.
- 6" high standard opening includes full floor to support appliance. Opening height is customizable from 5" to 8" in 1/16" increments.
- When cabinet width changes, all drawer widths remain equal.
- Cabinet back is recessed 3" to conceal supply lines. Drawer box depth is also 3" less due to the recessed back.
- All drawer boxes are 8" high.

BUCM/CSBUCM - Base Under Counter Microwave

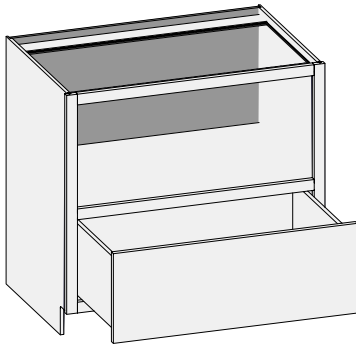

Custom Size Ranges
 Width: 24" – 36"
 Height: 31-1/2" – 42"
 Depth: 12", 15", 18",
 21", 24", 27", 30"

- For 34-1/2" high cabinets, top opening height is 15-3/4".
- When height changes, upper opening height changes. Lower opening height fixed at 10-1/4".

24" Deep	
BUCM2434.5	
BUCM2734.5	
BUCM3034.5	

BIUCM/CSBIUCM - Built-In Under Counter Microwave

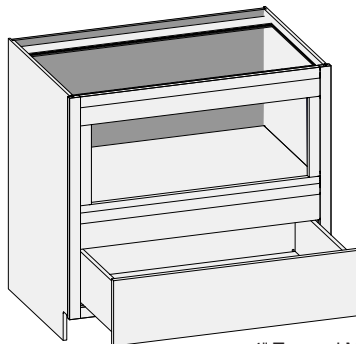

4" Top and Middle Rails

Custom Size Ranges
 Width: 24" – 36"
 Height: 31-1/2" – 42"
 Depth: 12", 15", 18",
 21", 24", 27", 30"

- Microwave opening is 13" high, width is 6" less than cabinet width.
- Microwave opening is trimmable up to 5" in height and 3" in width.
- For 34-1/2" high cabinets, top opening height is 13".
- When height changes, upper opening height changes. Lower opening height fixed at 8".

24" Deep	
BIUCM2734.5	BIUCM3334.5
BIUCM3034.5	BIUCM3634.5

BAE/CSBAE - Base Angle End

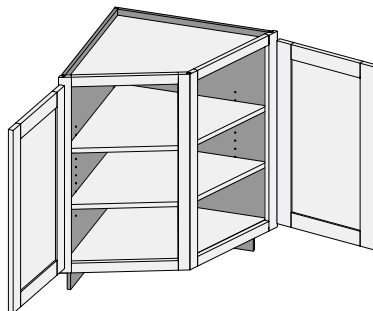

Custom Size Ranges
 Width: 24"
 Height: 31-1/2" – 42"
 Depth: 24"

- Two 15" wide openings.
- 1-13/16" wide stiles outside, 1-5/8" wide stiles inside.
- Unavailable Options: EXP, FL, FUE, SS, PFD, EXT, SBR, LE, TSS.

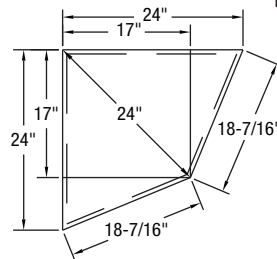

24" Deep	
BAE2434.5	

BEAR(L)/CSBEAR(L) - Base End Angle Right (or Left)

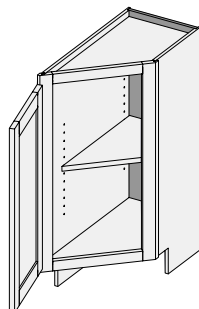

Custom Size Ranges
 Width: 12"
 Height: 31-1/2" – 42"
 Depth: 24"

- Units are reversible right or left (right shown).
- 1-13/16" stile face width.
- Flush end available on 12-1/2" deep side.
- Exposed end available on 24" deep side.
- Unavailable Options: SS, PFD, EXT, SBR, LE, TSS.

24" Deep	
BEAL1234.5	
BEAR1234.5	

Base Options Key: EXP = Exposed End(s) FL = Flush End(s) FUE = Flush Unexposed End(s) SS = Shaped Side PFD = Prep for False Door
 EXT = Extended Stile(s) FT = Flush Toe SBR = Shaped Bottom Rail LE = Leg Extension TSS = Toe Space Side OS = Omit Shelving
 NSH = No Shelf Holes WS = Solid Wood Shelves MI = Matching Interior DT = Dust Top PTB = Plywood Toe Backer

CSBDE - Base Double Entry w/Butt Doors

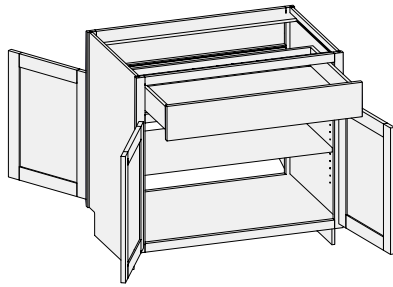

Custom Size Ranges
 Width: 24" – 36"
 Height: 31-1/2" – 42"
 Depth: 12", 15", 18",
 21", 24", 27", 30"

- One false drawer front on one side, functional top drawer on opposite side.
- When height changes, lower opening height changes. Drawer height fixed at 5".
- Specify single or butt doors on custom size cabinets 24" wide.
- Unavailable Options: LE and WS.

CSBDE2D1D - Base Double Entry Two Door One Drawer

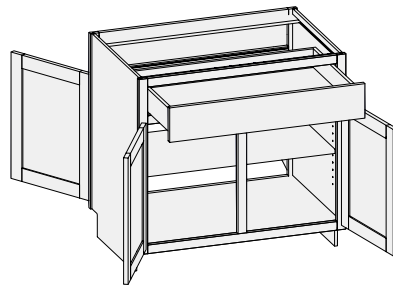

Custom Size Ranges
 Width: 27" – 36"
 Height: 31-1/2" – 42"
 Depth: 12", 15", 18",
 21", 24", 27", 30"

- One false drawer front on one side, functional top drawer on opposite side.
- When height changes, lower opening height changes. Drawer height fixed at 5".
- Unavailable Options: LE and WS.

BDE/CSBDECS - Base Double Entry w/Center Stile

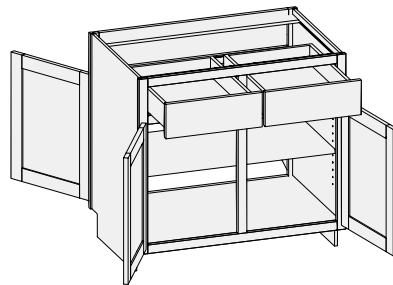

Custom Size Ranges
 Width: 30" – 48"
 Height: 31-1/2" – 42"
 Depth: 12", 15", 18",
 21", 24", 27", 30"

- Two false drawer fronts on one side, functional top drawers on opposite side.
- When height changes, lower opening height changes. Drawer height fixed at 5".
- Unavailable Options: LE and WS.

24" Deep	
BDE3034.5	BDE4234.5
BDE3634.5	BDE4834.5

CSBC3DL - Base Combo Three Drawer Left w/Butt Doors

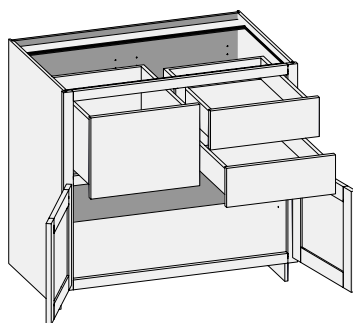

Custom Size Ranges
 Width: 24" – 36"
 Height: 31-1/2" – 42"
 Depth: 12", 15", 18",
 21", 24", 27", 30"

- When height changes, lower opening height changes. Drawer opening height fixed at 5" and 11-1/2".
- When width changes, drawer opening widths remain equal.

Base Options Key: EXP = Exposed End(s) FL = Flush End(s) FUE = Flush Unexposed End(s) SS = Shaped Side PFD = Prep for False Door
 EXT = Extended Stile(s) FT = Flush Toe SBR = Shaped Bottom Rail LE = Leg Extension TSS = Toe Space Side OS = Omit Shelving
 NSH = No Shelf Holes WS = Solid Wood Shelves MI = Matching Interior DT = Dust Top PTB = Plywood Toe Backer

CSBC3DLCS - Base Combo Three Drawer Left w/Center Stile

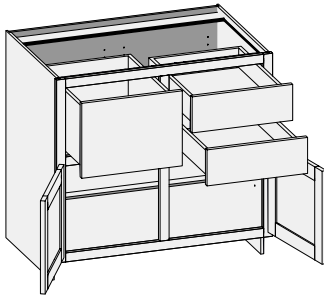

Custom Size Ranges
 Width: 27" – 48"
 Height: 31-1/2" – 42"
 Depth: 12", 15", 18",
 21", 24", 27", 30"

- When height changes, lower opening height changes. Drawer opening height is fixed at 5" and 11-1/2".
- When width changes, drawer opening widths remain equal.

CSBC3DR - Base Combo Three Drawer Right w/Butt Doors

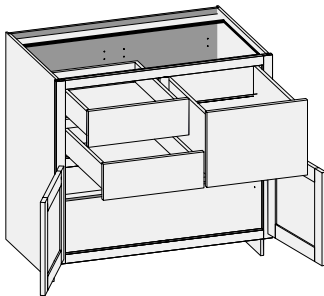

Custom Size Ranges
 Width: 24" – 36"
 Height: 31-1/2" – 42"
 Depth: 12", 15", 18",
 21", 24", 27", 30"

- When height changes, lower opening height changes. Drawer opening height is fixed at 5" and 11-1/2".
- When width changes, drawer opening widths remain equal.

CSBC3DRCS - Base Combo Three Drawer Right w/Center Stile

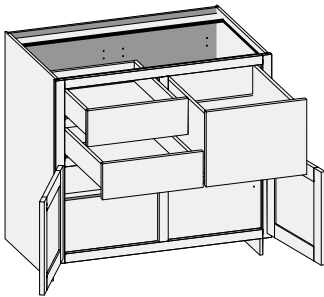

Custom Size Ranges
 Width: 27" – 48"
 Height: 31-1/2" – 42"
 Depth: 12", 15", 18",
 21", 24", 27", 30"

- When height changes, lower opening height changes. Drawer opening height is fixed at 5" and 11-1/2".
- When width changes, drawer opening widths remain equal.

CSBC4DCS - Base Combo Four Drawer

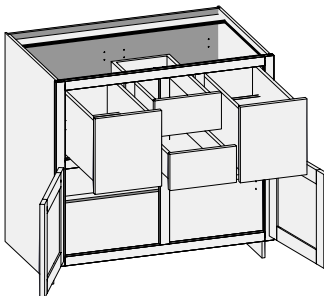

Custom Size Ranges
 Width: 36" – 48"
 Height: 31-1/2" – 42"
 Depth: 12", 15", 18",
 21", 24", 27", 30"

- When height changes, lower opening height changes. Drawer opening height is fixed at 5" and 11-1/2".
- When width changes, drawer opening widths remain equal.

Base Options Key: EXP = Exposed End(s) FL = Flush End(s) FUE = Flush Unexposed End(s) SS = Shaped Side PFD = Prep for False Door
 EXT = Extended Stile(s) FT = Flush Toe SBR = Shaped Bottom Rail LE = Leg Extension TSS = Toe Space Side OS = Omit Shelving
 NSH = No Shelf Holes WS = Solid Wood Shelves MI = Matching Interior DT = Dust Top PTB = Plywood Toe Backer

CSB2D5D - Base Two Door Five Drawer

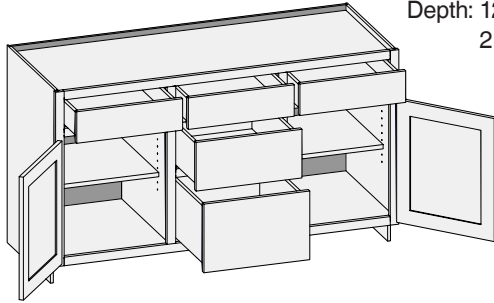

Custom Size Ranges
Width: 48" – 96"
Height: 31-1/2" – 34-1/2"
Depth: 12", 15", 18"
21", 24", 27", 30"

- Cabinet widths 48" to 72" have two doors; widths 60" to 96" have four butt doors.
- When height changes, lower opening heights change. Top drawer opening height fixed at 5". Middle drawer opening height fixed at 8".
- Doors hinged on center stile require 1/2" overlay hinges for 1-1/4" or 1-3/8" overlays.
- When width changes, all openings are configured equally.
- Fixed vertical partitions with independently adjustable shelves.
- Unavailable Option: PFD

CSBOU - Base Open Unit

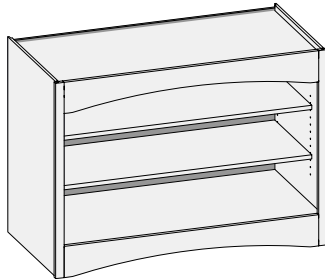

CWS4 – Roman Arch shown

Custom Size Ranges
Width: 15" – 48"
Height: 31-1/2" – 48"
Depth: 5-1/2" – 30"

- Available with valance designs on top and bottom rails. To order specify using CWS designations associated with the valance design.
- Top and bottom rails are 5-1/2" high for all valance designs and Flush Toe Option.
- If no valance design is selected, top rail is 1-1/2" high.
- When a toe kick is selected, bottom rail is 1-1/2" high.
- Minimum width is 15".
- Unavailable Option: WS.



CWS4 – Roman Arch

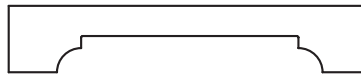

CWS6 – Elegant Arch

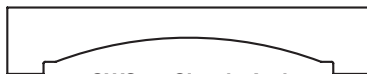

CWS5 – Classic Arch

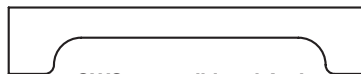

CWS7 – Traditional Arch

CSBPU - Base Pet Unit

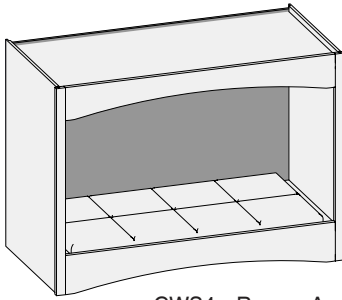

CWS4 – Roman Arch shown

Custom Size Ranges
 Width: 30" – 48"
 Height: 31-1/2" – 48"
 Depth: 15" – 24"

- Available with valance designs on top and bottom rails. To order specify using CWS designations associated with the valance design.
- Top rail is 5-1/2" for all valance designs.
- If no valance design is selected, top rail is 1-1/2" high.
- Bottom rail is 6-1/2" high for all valance designs and Flush Toe Option. 1" rail extension provides a lip to keep pet bed in place (pet bed not included).
- When a toe kick is selected, bottom rail is 2-1/2" high.
- Minimum width is 15".



CWS4 – Roman Arch

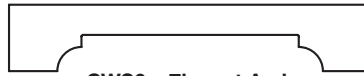

CWS6 – Elegant Arch



CWS5 – Classic Arch

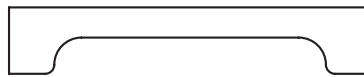

CWS7 – Traditional Arch

CSBCO - Base Case Only Cabinet

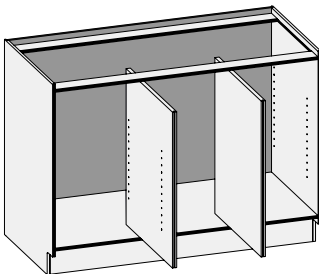

Partition D (Right)

Partition C (Left)

Custom Size Ranges
 Width: 9" – 96"
 Height: 8" – 48"
 Depth: 8" – 30"

- Customizable cabinet case for custom base applications.
- Sides are machined with shelf holes.
- Optional partitions are sized to fit between top stringers and bottom of cabinet. Self-tapping screws are provided to secure partition into place. Specify quantity of each style partition required.
 - Partition A has no shelf holes.
 - Partition B has thru holes.
 - Partition C has shelf holes on the left side. (Pairs with the right cabinet side).
 - Partition D has shelf holes on the right side. (Pairs with the Left cabinet side).
- Specify shelf quantity per cabinet and length of each shelf. Up to 4 different shelf lengths can be specified. Shelf depth is calculated automatically by the system.
- Order 1/2 overlay hinge kit #2100150A when mounting doors on a center stile.

Base Options Key: EXP = Exposed End(s) FL = Flush End(s) FUE = Flush Unexposed End(s) SS = Shaped Side PFD = Prep for False Door
 EXT = Extended Stile(s) FT = Flush Toe SBR = Shaped Bottom Rail LE = Leg Extension TSS = Toe Space Side OS = Omit Shelving
 NSH = No Shelf Holes WS = Solid Wood Shelves MI = Matching Interior DT = Dust Top PTB = Plywood Toe Backer

Advantage Tall Cabinet Standard Features and Options

The information described below discusses some of the features and options of Advantage Tall cabinets. Customers have the option to omit these standard features as well as add other design options, which can be quickly referenced at the bottom of each page in the Tall Cabinet Section labeled "Tall Options Key". For more detailed descriptions and images of all available options see Options, Section 12 within this manual. The options described below are available on all Tall cabinets unless specifically noted next to the individual cabinet as **Unavailable Options**.

Standard Shelving & Omit Shelving (OS) – 3/4" thick White Birch plywood shelving with a durable UV topcoat is standard with any Tall cabinet with shelves. If shelving is not desired within a specific cabinet, indicate **Omit Shelving Option** when ordering.

5mm Shelf Holes & No Shelf Holes (NSH) – Pre-drilled 5mm shelf holes on 32mm centers are a standard feature of all Tall cabinets with shelves. If shelf holes are not desired, indicate **No Shelf Holes Option** when ordering. **Note:** If shelving and shelf holes are not desired, both No Shelf Holes and Omit Shelving must be specified when ordering.

Cabinet Case Material Options – Most optional cabinet case materials will match the door, drawer front and face frame specie and are available with Tall cabinets produced in standard Advantage species.

- **Exposed Ends (EXP)** – Matching specie veneer on the exterior face of 1/2" thick plywood cabinet sides. The interior of plywood Exposed Ends will remain as White Birch.
- **Flush Ends (FL)** – Matching specie veneer on the exterior face of 3/4" thick plywood cabinet sides. The interior of plywood Flush Ends will remain as White Birch.
- **Flush Unexposed Ends (FUE)** – Natural Birch veneer on the exterior face of the 3/4" thick flush plywood cabinet sides. Designed to be utilized when extra support is desired from non-exposed flush end panels. The interior of the plywood Flush Unexposed Ends will remain as White Birch.
- **Matching Interior (MI)** – Matching specie veneer is available on all internal cabinet parts. The Matching Interior Option is not available in combination with the Solid Wood Shelf Upgrade Option.

Solid Wood Shelf Upgrade (WS) – The **Solid Wood Shelf Upgrade Option** replaces standard White Birch prefinished plywood shelving with solid wood Natural Birch shelving. The Solid Wood Shelving is 3/4" thick with a bullnosed front edge and finished with a UV topcoat. The Solid Wood Shelf Upgrade Option is not available in combination with the Matching Interior Option or when Tall cabinets are deeper than 24". Solid shelving available up to 18" deep.

Extended Stiles (EXT) – The **Extended Stile Option** provides additional width on the left, right or both stiles of the front frame. Up to 3" of additional material provides clearance between the cabinet and adjacent walls or other cabinetry allowing cabinet doors and drawers to fully open without interference. Extended stiles also provide the opportunity to scribe the frame to the wall contours during the installation process.

Leg Extension (LE) – the **Leg Extension Option** can be added to the left, right or both stiles of the front frame. When selected, the Leg Extension Option omits the toe kick from the cabinet and extends the front frame stile(s) to the floor creating a closed end panel to the cabinet.

Prep for False Door Side (PFD) – The **Prep for False Door Side Option** maintains the overall front frame width ordered, but relocates the cabinet side panel, moving it inward by 13/16" for each Prep for False Door Side selected. This creates a 3/4" reveal behind the 1-1/2" wide front frame stile to accommodate the decorative door end panel. The Prep for False Door Side Option can be ordered for the left, right or both cabinet sides. All cabinet components are automatically resized accordingly when the Prep for False Door Side Option is selected.

Square Toe Kick Notch (STN) – Standard Tall cabinet side panels have a 3-1/2" deep x 4" high toe kick notch with a 1/4" radius at the intersecting corner. This corner can be squared with the **Square Toe Notch Option** which makes the corner notch 90° to aid in toe board installation.

Flush Toe (FT) – When selected, the **Flush Toe Option** replaces the standard toe kick notches in both side panels with a 5-1/2" bottom rail on the front frame.

Shaped Bottom Rail (SBR) – The **Shaped Bottom Rail Option** automatically adds the Flush Toe to the cabinet's front frame. The 5-1/2" wide bottom rail gives customers the choice of 6 decorative shapes on the bottom rail of the Flush Toe, providing a furniture type appearance.

Shaped Side (SS) – The **Shaped Side Option** provides a choice of 4 decorative shapes on the bottom of Exposed Ends or Flush Ends. The Shaped Side Option is available on left, right, or both sides, but is not available in combination with Extended Stiles, Flushed Unexposed Ends or Loose Toe Platform.

Toe Space Side (TSS) – The **Toe Space Side Option** replaces the bottom 4" of the side panel with a recessed toe space on the left, right or both sides of most Tall cabinets. This option is commonly used on island or peninsula cabinet sides.

Loose Toe Platform (LTP) – When the **Loose Toe Platform Option** is selected, the overall Tall cabinet height is reduced by removing the toe kick from the front of the cabinet and 4" from the side panels and cabinet back. A separate 4" platform is provided to achieve the overall desired cabinet height. The Loose Toe Platform Option is available with most Tall cabinets, but is not available in combination with the Flush Toe or Square Toe Notch Options.

UCD/CSUC - Utility Cabinet

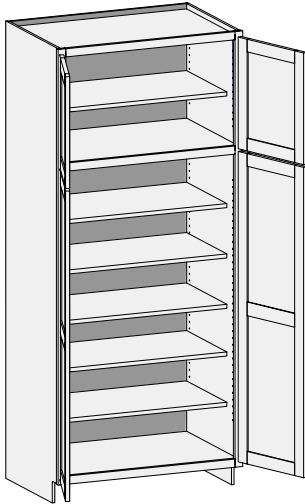

Custom Size Ranges
 Single Door Width: 12" – 24"
 Butt Door Width: 24" – 36"
 Height: 84" – 120"
 Depth: 5-1/2" – 30"

- Matching specie interior is not available over 96" high. White Birch UV topcoated material will be used.
- When height changes, upper opening height changes. Lower opening height fixed at 56".
- 84" – 90" high has six shelves.
- 90-1/16" – 96" high has seven shelves.
- 96-1/16" – 108" high has eight shelves.
- 108-1/16" – 120" high has nine shelves.
- Specify single or butt doors on custom size cabinets 24" wide.

Single Door Cabinet – 24" Deep			Butt Door Cabinet – 24" Deep		
84" High	90" High	96" High	84" High	90" High	96" High
UCD1584	UCD1590	UCD1596	UCD2484BD	UCD2490BD	UCD2496BD
UCD1884	UCD1890	UCD1896	UCD2784BD	UCD2790BD	UCD2796BD
UCD2184	UCD2190	UCD2196	UCD3084BD	UCD3090BD	UCD3096BD
UCD2484	UCD2490	UCD2496	UCD3384BD	UCD3390BD	UCD3396BD
			UCD3684BD	UCD3690BD	UCD3696BD

UCD/CSUCCS - Utility Cabinet w/Center Stile

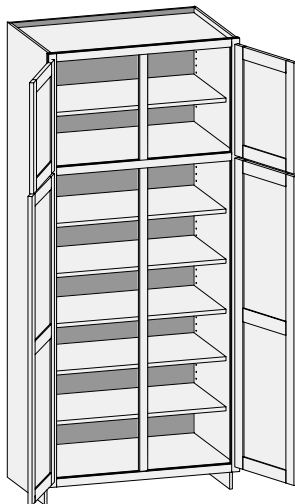

Custom Size Ranges
 Width: 27" – 36"
 Height: 84" – 120"
 Depth: 5-1/2" – 30"

- Matching specie interior is not available over 96" high. White Birch UV topcoated material will be used.
- When height changes, upper opening height changes. Lower opening height fixed at 56".
- 84" – 90" high has six shelves.
- 90-1/16" – 96" high has seven shelves.
- 96-1/16" – 108" high has eight shelves.
- 108-1/16" – 120" high has nine shelves.

84" High	90" High	96" High
UCD2784	UCD2790	UCD2796
UCD3084	UCD3090	UCD3096
UCD3384	UCD3390	UCD3396
UCD3684	UCD3690	UCD3696

Options Key: EXP = Exposed End(s) FL = Flush End(s) FUE = Flush Unexposed End(s) SS = Shaped Side PFD = Prep for False Door
 EXT = Extended Stile(s) FT = Flush Toe LTP = Loose Toe Platform SBR = Shaped Bottom Rail LE = Leg Extension OS = Omit Shelving
 NSH = No Shelf Holes WS = Solid Wood Shelves MI = Matching Interior PTB = Plywood Toe Backer

UCDW/CSUCW - Utility Cabinet Wall Height Top Section

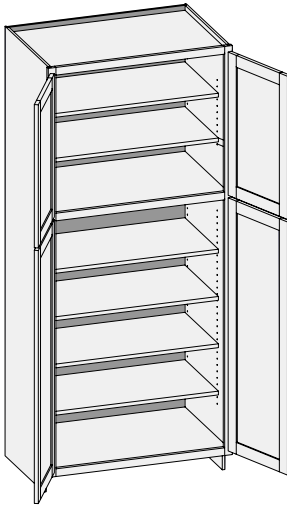

Custom Size Ranges
 Single Door Width: 12" – 24"
 Butt Door Width: 24" – 36"
 Height: 84" – 120"
 Depth: 5-1/2" – 30"

- Top section aligns with corresponding wall cabinet height as follows:
 84" high – 30" wall cabinets.
 90" high – 36" wall cabinets.
 96" high – 42" wall cabinets.
- Matching specie interior is not available over 96" high. White Birch UV topcoated material will be used.
- When cabinet height changes, top opening height changes accordingly. Lower opening height is fixed at 48-1/2".
- 84" – 90" high has six shelves.
- 90-1/16" – 96" high has seven shelves.
- 96-1/16" – 108" high has eight shelves.
- 108-1/16" – 120" high has nine shelves.
- Specify single or butt doors on custom size cabinets 24" wide.

Single Door Cabinet – 24" Deep			Butt Door Cabinet – 24" Deep		
84" High	90" High	96" High	84" High	90" High	96" High
UCDW1584	UCDW1590	UCDW1596	UCDW2484BD	UCDW2490BD	UCDW2496BD
UCDW1884	UCDW1890	UCDW1896	UCDW2784BD	UCDW2790BD	UCDW2796BD
UCDW2184	UCDW2190	UCDW2196	UCDW3084BD	UCDW3090BD	UCDW3096BD
UCDW2484	UCDW2490	UCDW2496	UCDW3384BD	UCDW3390BD	UCDW3396BD
			UCDW3684BD	UCDW3690BD	UCDW3696BD

CSUCWCS - Utility Cabinet Wall Height Top Section w/Center Stile

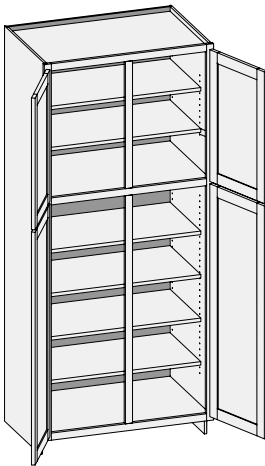

Custom Size Ranges
 Width: 27" – 36"
 Height: 84" – 120"
 Depth: 5-1/2" – 30"

- Top section aligns with corresponding wall cabinet height as follows:
 84" high – 30" wall cabinets.
 90" high – 36" wall cabinets.
 96" high – 42" wall cabinets.
- Matching specie interior is not available over 96" high. White Birch UV topcoated material will be used.
- When cabinet height changes, top opening height changes accordingly. Lower opening height is fixed at 48-1/2".
- 84" – 90" high has six shelves.
- 90-1/16" – 96" high has seven shelves.
- 96-1/16" – 108" high has eight shelves.
- 108-1/16" – 120" high has nine shelves.

Options Key: EXP = Exposed End(s) FL = Flush End(s) FUE = Flush Unexposed End(s) SS = Shaped Side PFD = Prep for False Door
 EXT = Extended Stile(s) FT = Flush Toe LTP = Loose Toe Platform SBR = Shaped Bottom Rail LE = Leg Extension OS = Omit Shelving
 NSH = No Shelf Holes WS = Solid Wood Shelves MI = Matching Interior PTB = Plywood Toe Backer

UCDR/CSUCR - Utility Cabinet Reverse

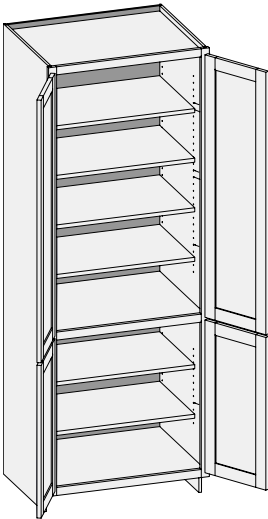

Custom Size Ranges
 Single Door Width: 12" – 24"
 Butt Door Width: 24" – 36"
 Height: 84" – 120"
 Depth: 5-1/2" – 30"

- Matching specie interior is not available over 96" high. White Birch UV topcoated material will be used.
- When height changes, upper opening height changes. Lower opening height fixed at 27-1/2".
- 84" – 90" high has six shelves.
- 90-1/16" – 96" high has seven shelves.
- 96-1/16" – 108" high has eight shelves.
- 108-1/16" – 120" high has nine shelves.
- Specify single or butt doors on custom size cabinets 24" wide.

Single Door Cabinet – 24" Deep			Butt Door Cabinet – 24" Deep		
84" High	90" High	96" High	84" High	90" High	96" High
UCDR1584	UCDR1590	UCDR1596	UCDR2484BD	UCDR2490BD	UCDR2496BD
UCDR1884	UCDR1890	UCDR1896	UCDR2784BD	UCDR2790BD	UCDR2796BD
UCDR2184	UCDR2190	UCDR2196	UCDR3084BD	UCDR3090BD	UCDR3096BD
UCDR2484	UCDR2490	UCDR2496	UCDR3384BD	UCDR3390BD	UCDR3396BD
			UCDR3684BD	UCDR3690BD	UCDR3696BD

CSUCRCS - Utility Cabinet Reverse w/Center Stile

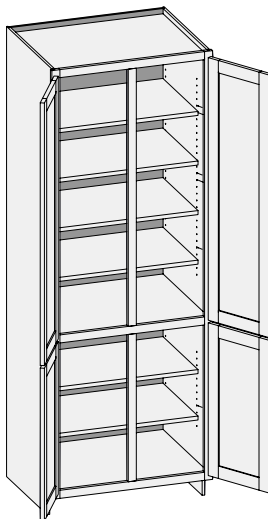

Custom Size Ranges
 Width: 27" – 36"
 Height: 84" – 120"
 Depth: 5-1/2" – 30"

- Matching specie interior is not available over 96" high. White Birch UV topcoated material will be used.
- When height changes, upper opening height changes. Lower opening height fixed at 27-1/2".
- 84" – 90" high has six shelves.
- 90-1/16" – 96" high has seven shelves.
- 96-1/16" – 108" high has eight shelves.
- 108-1/16" – 120" high has nine shelves.

Options Key: EXP = Exposed End(s) FL = Flush End(s) FUE = Flush Unexposed End(s) SS = Shaped Side PFD = Prep for False Door
 EXT = Extended Stile(s) FT = Flush Toe LTP = Loose Toe Platform SBR = Shaped Bottom Rail LE = Leg Extension OS = Omit Shelving
 NSH = No Shelf Holes WS = Solid Wood Shelves MI = Matching Interior PTB = Plywood Toe Backer

UCDRRO/CSUCRRO - Utility Cabinet Deep Reverse Roll-Out

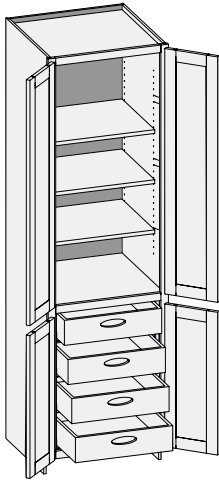

Custom Size Ranges
 Single Door Width: 12" – 24"
 Butt Door Width: 24" – 36"
 Height: 84" – 120"
 Depth: 12", 15", 18",
 21", 24", 27", 30"

- Units are configured with four 5" high drawer boxes. Interior panels are pre-drilled for drawer slide placement and installation.
- Roll-out drawers include hand pulls. Specify Standard, Circle or Ellipse (shown) pull.
- Matching specie interior is not available over 96" high. White Birch UV topcoated material will be used.
- When height changes, upper opening height changes. Lower opening height fixed at 27-1/2".
- 84" – 90" high has four shelves.
- 90-1/16" – 96" high has five shelves.
- 96 1/16" – 108" high has six shelves.
- 108-1/16" – 120" has seven shelves.
- Specify single or butt doors on custom size cabinets 24" wide.

Single Door Cabinet –24" Deep			Butt Door Cabinet – 24" Deep		
84" High	90" High	96" High	84" High	90" High	96" High
UCDRRO1584	UCDRRO1590	UCDRRO1596	UCDRRO2484BD	UCDRRO2490BD	UCDRRO2496BD
UCDRRO1884	UCDRRO1890	UCDRRO1896	UCDRRO2784BD	UCDRRO2790BD	UCDRRO2796BD
UCDRRO2184	UCDRRO2190	UCDRRO2196	UCDRRO3084BD	UCDRRO3090BD	UCDRRO3096BD
UCDRRO2484	UCDRRO2490	UCDRRO2496	UCDRRO3384BD	UCDRRO3390BD	UCDRRO3396BD
			UCDRRO3684BD	UCDRRO3690BD	UCDRRO3696BD

UCDRROI/CSUCRROI - Utility Cabinet Deep Reverse Roll-Out Inset

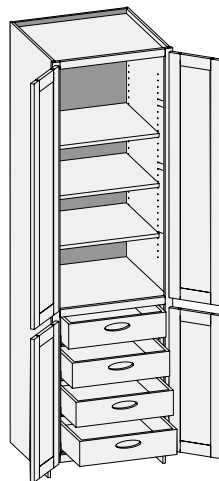

Custom Size Ranges
 Single Door Width: 15" – 36"
 Butt Door Width: 24" – 36"
 Height: 84" – 120"
 Depth: 12", 15", 18",
 21", 24", 27", 30"

- Specifically designed for inset applications.
- Units are configured with four 5" high drawer boxes.
- Interior panels are pre-drilled for drawer slide placement and installation.
- Roll-out drawers include hand pulls. Specify Standard, Circle or Ellipse (shown) pull.
- Matching specie interior is not available over 96" high. White Birch UV topcoated material will be used.
- When height changes, upper opening height changes. Lower opening height fixed at 27-1/2".
- 84" – 90" high has four shelves.
- 90-1/16" – 96" high has five shelves.
- 96 1/16" – 108" high has six shelves.
- 108-1/16" – 120" has seven shelves.
- Specify single or butt doors on custom size cabinets 24" wide.

Single Door Cabinet –24" Deep			Butt Door Cabinet –24" Deep		
84" High	90" High	96" High	84" High	90" High	96" High
UCDRROI1584	UCDRROI1590	UCDRROI1596	UCDRROI2484BD	UCDRROI2490BD	UCDRROI2496BD
UCDRROI1884	UCDRROI1890	UCDRROI1896	UCDRROI2784BD	UCDRROI2790BD	UCDRROI2796BD
UCDRROI2184	UCDRROI2190	UCDRROI2196	UCDRROI3084BD	UCDRROI3090BD	UCDRROI3096BD
UCDRROI2484	UCDRROI2490	UCDRROI2496	UCDRROI3384BD	UCDRROI3390BD	UCDRROI3396BD
			UCDRROI3684BD	UCDRROI3690BD	UCDRROI3696BD

Options Key: EXP = Exposed End(s) FL = Flush End(s) FUE = Flush Unexposed End(s) SS = Shaped Side PFD = Prep for False Door
 EXT = Extended Stile(s) FT = Flush Toe LTP = Loose Toe Platform SBR = Shaped Bottom Rail LE = Leg Extension OS = Omit Shelving
 NSH = No Shelf Holes WS = Solid Wood Shelves MI = Matching Interior PTB = Plywood Toe Backer

U2D/CSU2D - Utility Two Drawer

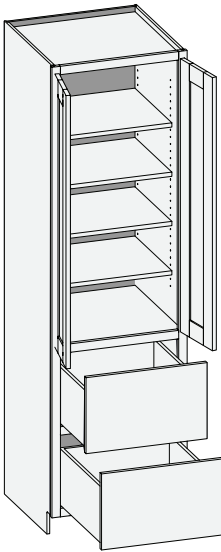

Custom Size Ranges
 Single Door Width: 12" – 24"
 Butt Door Width: 24" – 36"
 Height: 84" – 120"
 Depth: 12", 15", 18", 21", 24",
 27", 30"

- Matching specie interior is not available over 96" high. White Birch UV topcoated material will be used.
- When height changes, upper opening height changes.
- Lower drawer section aligns with 34-1/2" high base cabinets. Drawer front heights are equal.
- 84" – 90" high has four shelves.
- 90-1/16" – 96" high has five shelves.
- 96-1/16" – 108" high has six shelves.
- 108-1/16" 120" high has seven shelves.
- Specify single or butt doors on custom size cabinets 24" wide.

Single Door Cabinet – 24" Deep			Butt Door Cabinet – 24" Deep		
84" High	90" High	96" High	84" High	90" High	96" High
U2D1884	U2D1890	U2D1896	U2D2484BD	U2D2490BD	U2D2496BD
U2D2184	U2D2190	U2D2196	U2D2784BD	U2D2790BD	U2D2796BD
U2D2484	U2D2490	U2D2496	U2D3084BD	U2D3090BD	U2D3096BD
			U2D3384BD	U2D3390BD	U2D3396BD
			U2D3684BD	U2D3690BD	U2D3696BD

U3D/CSU3D - Utility Three Drawer

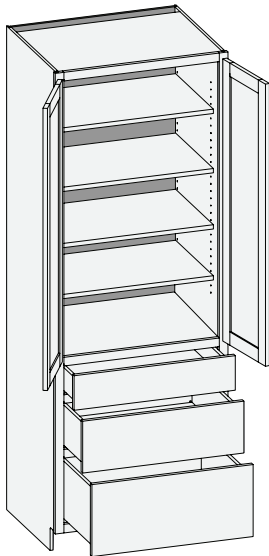

Custom Size Ranges
 Single Door Width: 12" – 24"
 Butt Door Width: 24" – 36"
 Height: 84" – 120"
 Depth: 12", 15", 18",
 21", 24", 27", 30"

- Matching specie interior is not available over 96" high. White Birch UV topcoated material will be used.
- When height changes, upper opening height changes.
- Lower drawer section aligns with 34-1/2" high base cabinets.
- 84" – 90" high has four shelves.
- 90-1/16" – 96" high has five shelves.
- 96-1/16" – 108" high has eight shelves.
- 108-1/16" – 120" high has nine shelves.
- Specify single or butt doors on custom size cabinets 24" wide.

Single Door Cabinet – 24" Deep			Butt Door Cabinet – 24" Deep		
84" High	90" High	96" High	84" High	90" High	96" High
U3D1884	U3D1890	U3D1896	U3D2484BD	U3D2490BD	U3D2496BD
U3D2184	U3D2190	U3D2196			
U3D2484	U3D2490	U3D2496			

Options Key: EXP = Exposed End(s) FL = Flush End(s) FUE = Flush Unexposed End(s) SS = Shaped Side PFD = Prep for False Door
 EXT = Extended Stile(s) FT = Flush Toe LTP = Loose Toe Platform SBR = Shaped Bottom Rail LE = Leg Extension OS = Omit Shelving
 NSH = No Shelf Holes WS = Solid Wood Shelves MI = Matching Interior PTB = Plywood Toe Backer

ODA/CSODA - Oven Double Opening Type A w/Butt Doors

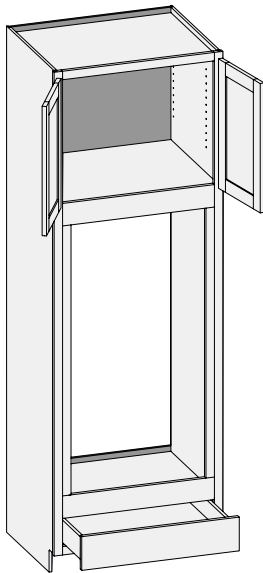

4" Middle Rails

Custom Size Ranges
Width: 27" – 36"
Height: 84" – 120"
Depth: 24", 27", 30"

- Oven opening is 48" high, width is 6" less than cabinet width.
- Oven opening is trimmable up to 5" in height and 3" in width.
- Oven opening is 14-1/2" above the floor, trimmable to 12".
- Matching specie interior is not available over 96" high. White Birch UV topcoated material will be used.
- When height changes, upper opening height changes. Lower and middle opening heights fixed.
- 84" – 95" high has one shelf.
- 95-1/16" – 102" high has two shelves.
- 102-1/16" – 120" high has three shelves.
- ODA with center stile and two functional side by side drawers below oven opening available. Order using CSODACS.

24" Deep		
84" High	90" High	96" High
ODA2784BD	ODA2790BD	ODA2796BD
ODA3084BD	ODA3090BD	ODA3096BD
ODA3384BD	ODA3390BD	ODA3396BD

ODB/CSODB - Oven Double Opening Type B w/Butt Doors

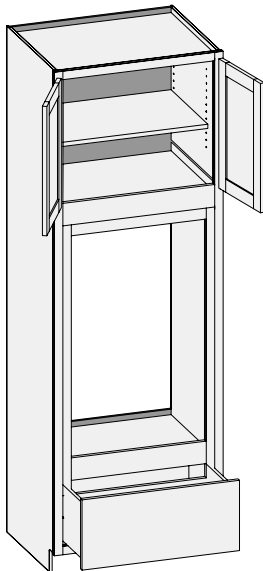

4" Middle Rails

Custom Size Ranges
Width: 27" – 36"
Height: 84" – 120"
Depth: 24", 27", 30"

- Oven opening is 39-1/2" high, width is 6" less than cabinet width.
- Oven opening is trimmable up to 5" in height and 3" in width.
- Oven opening is 21" above the floor, trimmable to 18-1/2".
- Matching specie interior is not available over 96" high. White Birch UV topcoated material will be used.
- When height changes, upper opening height changes. Lower and middle opening heights fixed.
- 84" – 95" high has one shelf.
- 95-1/16" – 102" high has two shelves.
- 102-1/16" – 120" high has three shelves.
- ODB with center stile and two functional side by side drawers below oven opening is available. Order using CSODBCS.

24" Deep		
84" High	90" High	96" High
ODB3084BD	ODB3090BD	ODB3096BD
ODB3384BD	ODB3390BD	ODB3396BD

Options Key: EXP = Exposed End(s) FL = Flush End(s) FUE = Flush Unexposed End(s) SS = Shaped Side PFD = Prep for False Door
EXT = Extended Stile(s) FT = Flush Toe LTP = Loose Toe Platform SBR = Shaped Bottom Rail LE = Leg Extension OS = Omit Shelving
NSH = No Shelf Holes WS = Solid Wood Shelves MI = Matching Interior PTB = Plywood Toe Backer

CSOS - Oven Single Opening w/Butt Doors

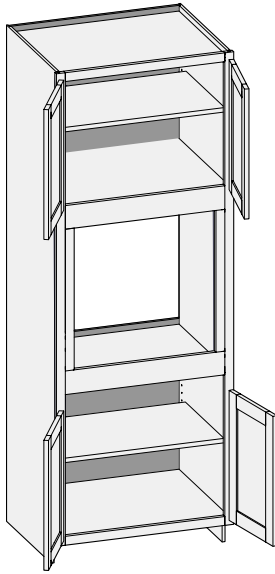

4" Middle Rails

Custom Size Ranges
 Width: 27" – 36"
 Height: 84" – 120"
 Depth: 24" – 30"

- Oven opening is 24" high, width is 6" less than cabinet width.
- Oven opening is trimmable up to 5" in height and 3" in width.
- Oven opening is 33-1/2" above the floor, trimmable to 31".
- Matching specie interior is not available over 96" high. White Birch UV topcoated material will be used.
- When height changes, upper opening height changes. Lower and middle opening heights fixed.
- Lower opening is fixed at 24".
- 84" – 89" high has two shelves.
- 89-1/16" – 96" high has three shelves.
- 96-1/6" – 108" high has four shelves.
- 108-1/16" – 120" high has five shelves.
- OS with center stile in top and bottom opening is available. Order using CSOSCS.

CSRTB - Refrigerator Tall Both Sides w/Butt Doors

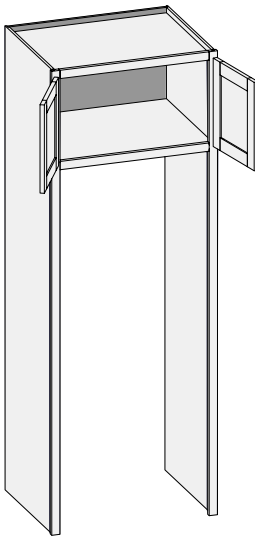

Custom Size Ranges
 Width: 30" – 36"
 Height: 84" – 120"
 Depth: 8" – 30"

- Middle numbers in the cabinet code refer to the height of the wall cabinet (example: RTB331284 has a 12" high upper cabinet).
- Matching specie interior is not available over 96" high. White Birch UV topcoated material will be used.
- When ordering custom size refrigerator cabinets specify top cabinet height.
- 21" – 24" high upper cabinets have one shelf.
- 24-1/16" – 27" high upper cabinet has two shelves.
- Unavailable options: SS, FT, SBR, LE, LTP.

Options Key: EXP = Exposed End(s) FL = Flush End(s) FUE = Flush Unexposed End(s) SS = Shaped Side PFD = Prep for False Door
 EXT = Extended Stile(s) FT = Flush Toe LTP = Loose Toe Platform SBR = Shaped Bottom Rail LE = Leg Extension OS = Omit Shelving
 NSH = No Shelf Holes WS = Solid Wood Shelves MI = Matching Interior PTB = Plywood Toe Backer

CSRTBCS - Refrigerator Tall Both Sides w/Center Stile

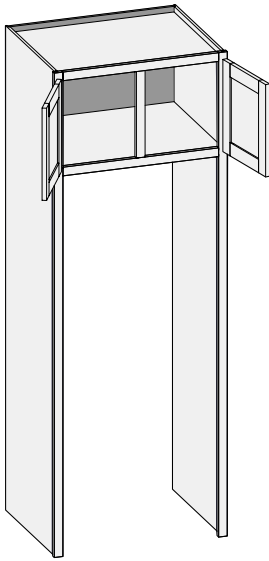

Custom Size Ranges
 Width: 30" – 51"
 Height: 84" – 120"
 Depth: 8" – 30"

- Middle numbers in the cabinet code refer to the height of the wall cabinet (example: RTB331284 has a 12" high upper cabinet).
- Matching specie interior is not available over 96" high. White Birch UV topcoated material will be used.
- When ordering custom size refrigerator cabinets specify top cabinet height.
- 21" – 24" high upper cabinet has one shelf.
- 24-1/16" – 27" high upper cabinet has two shelves.
- Unavailable Options: SS, FT, SBR, LE, LTP.

CSRTBHKXS - Refrigerator Tall Both w/HK-XS Lift System

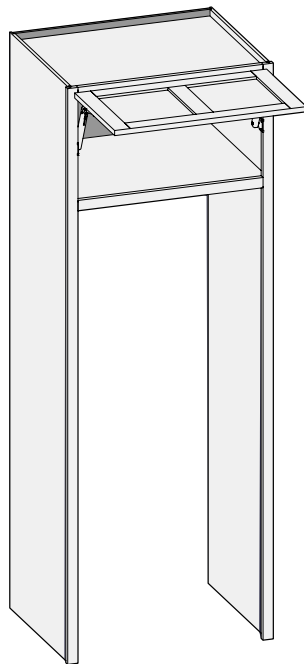

Custom Size Ranges
 Width: 15" – 42"
 Height: 84" – 120"
 Depth: 24" – 30"

- Preconfigured units include HK-XS Series lift system hardware and Blum COMPACT hinges.
- Door weight and design determine the strength and quantity of lift mechanisms provided.
- Cabinet width 15" – 24" are single panel door designs. 24-1/16" – 42" are two panels side by side. Upcharges for 2 panel door applies.
- Rabbeted edge profiles and inset/prefit options are not available.
- Matching specie interior is not available over 96" high. White Birch UV topcoated material will be used.
- When ordering custom size refrigerator cabinets specify top cabinet height.
- 12" – 18" high upper cabinet has no shelves.
- 18-1/16" – 24" high upper cabinet has one shelf.
- Unavailable Options: SS, FT, SBR, LE, LTP.

Options Key: EXP = Exposed End(s) FL = Flush End(s) FUE = Flush Unexposed End(s) SS = Shaped Side PFD = Prep for False Door
 EXT = Extended Stile(s) FT = Flush Toe LTP = Loose Toe Platform SBR = Shaped Bottom Rail LE = Leg Extension OS = Omit Shelving
 NSH = No Shelf Holes WS = Solid Wood Shelves MI = Matching Interior PTB = Plywood Toe Backer

CSRTL - Refrigerator Tall Left w/Butt Doors

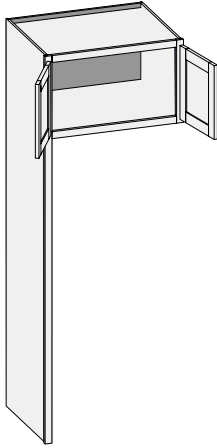

Custom Size Ranges
 Width: 30" – 36"
 Height: 84" – 120"
 Depth: 8" – 30"

- Middle numbers in the cabinet code refer to the height of the wall cabinet (example: RTB331284 has a 12" high upper cabinet).
- Matching specie interior is not available over 96" high. White Birch UV topcoated material will be used.
- When ordering custom size refrigerator cabinets specify top cabinet height.
- 21" – 24" high upper cabinets have one shelf.
- 24-1/16" – 27" high upper cabinet has two shelves.
- Unavailable Options: SS, FT, SBR, LE, LTP.

CSRTLCS - Refrigerator Tall Left w/Center Stile

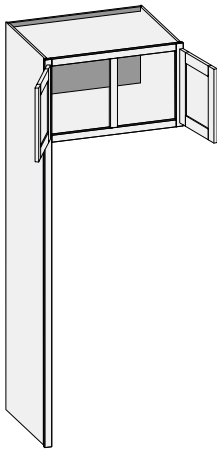

Custom Size Ranges
 Width: 30" – 51"
 Height: 84" – 120"
 Depth: 8" – 30"

- Middle numbers in the cabinet code refer to the height of the wall cabinet (example: RTB331284 has a 12" high upper cabinet).
- Matching specie interior is not available over 96" high. White Birch UV topcoated material will be used.
- When ordering custom size refrigerator cabinets specify top cabinet height.
- 21" – 24" high upper cabinets have one shelf.
- 24-1/16" – 27" high upper cabinet has two shelves.
- Unavailable Options: SS, FT, SBR, LE, LTP.

RTLHKXS/CSRTLHKXS - Refrigerator Tall Left w/HK-XS Lift System

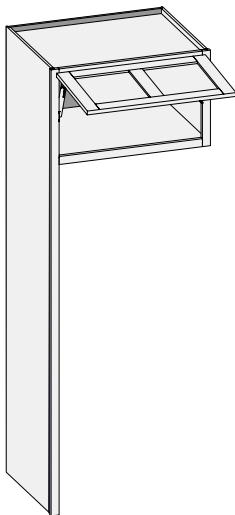

Custom Size Ranges
 Width: 15" – 42"
 Height: 84" – 120"
 Depth: 24" – 30"

- Preconfigured units include HK-XS Series lift system hardware and Blum COMPACT hinges.
- Door weight and design determine the strength and quantity of lift mechanisms provided.
- Cabinet width 15" – 24" are single panel door designs. 24-1/16" – 42" are two panels side by side. Upcharges for 2 panel door applies.
- Rabbeted edge profiles and inset/prefit options are not available.
- Middle numbers in the cabinet code refer to the height of the wall cabinet (example: RTLHKXS331284 has a 12" high upper cabinet).
- Matching specie interior is not available over 96" high. White Birch UV topcoated material will be used.
- When ordering custom size refrigerator cabinets specify top cabinet height.
- 12" – 18" high upper cabinet has no shelves.
- 18-1/16" – 24" high upper cabinet has one shelf.
- Unavailable Options: SS, FT, SBR, LE, LTP.

Options Key: EXP = Exposed End(s) FL = Flush End(s) FUE = Flush Unexposed End(s) SS = Shaped Side PFD = Prep for False Door
 EXT = Extended Stile(s) FT = Flush Toe LTP = Loose Toe Platform SBR = Shaped Bottom Rail LE = Leg Extension OS = Omit Shelving
 NSH = No Shelf Holes WS = Solid Wood Shelves MI = Matching Interior PTB = Plywood Toe Backer

RTR/CSRTR - Refrigerator Tall Right w/Butt Doors

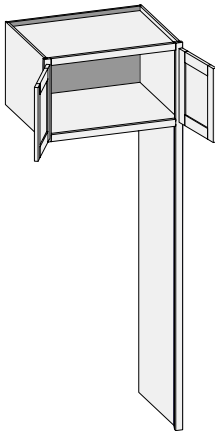

Custom Size Ranges
 Width: 30" – 36"
 Height: 84" – 120"
 Depth: 8" – 30"

- Middle numbers in the cabinet code refer to the height of the wall cabinet (example: RTB331284 has a 12" high upper cabinet).
- Matching specie interior is not available over 96" high. White Birch UV topcoated material will be used.
- When ordering custom size refrigerator cabinets specify top cabinet height.
- 21" – 24" high upper cabinets have one shelf.
- 24-1/16" – 27" high upper cabinet has two shelves.
- Unavailable Options: SS, FT, SBR, LE, LTP.

RTR/CSRTRCS - Refrigerator Tall Right w/Center Stile

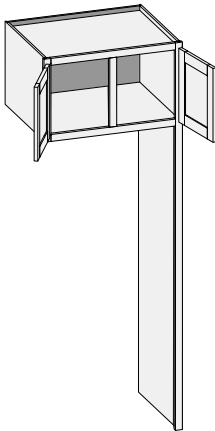

Custom Size Ranges
 Width: 30" – 51"
 Height: 84" – 120"
 Depth: 8" – 30"

- Middle numbers in the cabinet code refer to the height of the wall cabinet (example: RTB331284 has a 12" high upper cabinet).
- Matching specie interior is not available over 96" high. White Birch UV topcoated material will be used.
- When ordering custom size refrigerator cabinets specify top cabinet height.
- 21" – 24" high upper cabinets have one shelf.
- 24-1/16" – 27" high upper cabinet has two shelves.
- Unavailable Options: SS, FT, SBR, LE, LTP.

RTRHKXS/CSRTRHKXS - Refrigerator Tall Right w/HK-XS Lift System

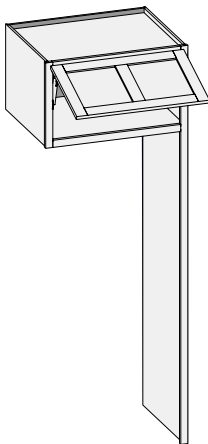

Custom Size Ranges
 Width: 15" – 42"
 Height: 84" – 120"
 Depth: 24" – 30"

- Preconfigured units include HK-XS Series lift system hardware and Blum COMPACT hinges.
- Door weight and design determine the strength and quantity of lift mechanisms provided.
- Cabinet width 15" – 24" are single panel door designs. 24-1/16" – 42" are two panels side by side. Upcharges for 2 panel door applies.
- Rabbeted edge profiles and inset/prefit options are not available.
- Middle numbers in the cabinet code refer to the height of the wall cabinet (example: RTRHKXS331284 has a 12" high upper cabinet).
- Matching specie interior is not available over 96" high. White Birch UV topcoated material will be used.
- When ordering custom size refrigerator cabinets specify top cabinet height.
- 12" – 18" high upper cabinet has no shelves.
- 18-1/16" – 24" high upper cabinet has one shelf.
- Unavailable Options: SS, FT, SBR, LE, LTP.

Options Key: EXP = Exposed End(s) FL = Flush End(s) FUE = Flush Unexposed End(s) SS = Shaped Side PFD = Prep for False Door
 EXT = Extended Stile(s) FT = Flush Toe LTP = Loose Toe Platform SBR = Shaped Bottom Rail LE = Leg Extension OS = Omit Shelving
 NSH = No Shelf Holes WS = Solid Wood Shelves MI = Matching Interior PTB = Plywood Toe Backer

TCH/CSTCH - Tall Corner Hutch w/Butt Doors

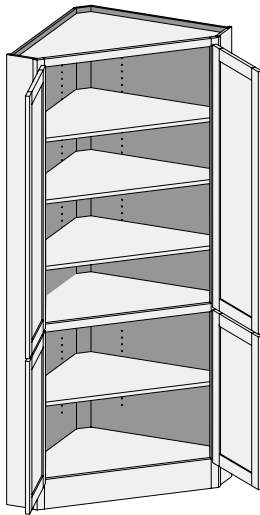

25-7/16" Face
26-9/16" Frame

Custom Size Ranges
Width: 24", 27", 30"
Height: 84" – 96"
Depth: 24", 27", 30"

- 5-1/2" Flush Toe standard.
- Lower section aligns with 34-1/2" high base cabinets.
- When height changes, upper opening height changes. Lower opening height fixed at 27-1/2".
- Cabinet is designed with Flush Toe standard.
- Unavailable Options: FUE, SS, PFD, LE, LTP, WS, EXT, SBR.

CSCO - Case Only

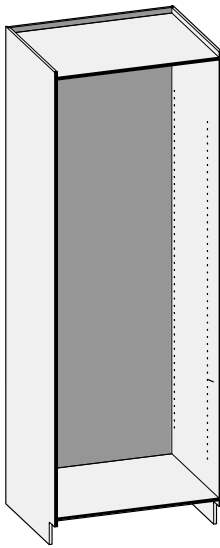

Custom Size Ranges
 Width: 9" – 48"
 Height: 10" – 120"
 Depth: 5-1/2" – 30"



Loose fixed floor kits

- Customizable cabinet case for custom base and tall applications.
- No front frame included – case only. Order custom size front frame, shelves, doors, drawer fronts and drawer boxes separately.
- Sides are machined with shelf holes.
- Loose fixed floor kits are sized to fit between sides. Plywood cleats included to mount floors as needed behind front frame openings. Floors include pre-inserted splines. Specify quantity of fixed floor kits per cabinet.
- Matching specie interior is not available over 96" high. White Birch UV topcoated material will be used.
- Custom quantities of fixed floor kits are available. Specify the quantity per cabinet.
- Specify shelf quantity per cabinet.
- Use Conestoga's online ordering system, Con-Nex or Conestoga order entry for pricing.

CSCONH - Case Only No Shelf Holes

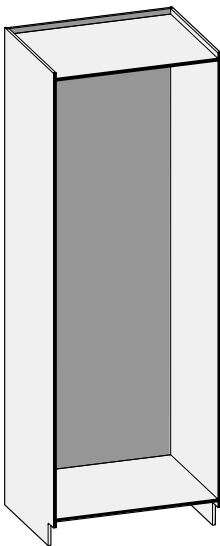

Custom Size Ranges
 Width: 9" – 48"
 Height: 10" – 120"
 Depth: 5-1/2" – 30"



Loose fixed floor kits

- Customizable cabinet case for custom base and tall applications.
- No front frame included – case only. Order custom size front frame, doors, drawer fronts and drawer boxes separately.
- Loose fixed floor kits are sized to fit between sides. Plywood cleats included to mount floors as needed behind front frame openings. Floors include pre-inserted splines. Specify quantity of fixed floor kits per cabinet.
- Matching specie interior is not available over 96" high. White Birch UV topcoated material will be used.
- Use Conestoga's online ordering system, Con-Nex or Conestoga order entry for pricing.

Options Key: EXP = Exposed End(s) FL = Flush End(s) FUE = Flush Unexposed End(s) SS = Shaped Side PFD = Prep for False Door
 EXT = Extended Stile(s) FT = Flush Toe LTP = Loose Toe Platform SBR = Shaped Bottom Rail LE = Leg Extension OS = Omit Shelving
 NSH = No Shelf Holes WS = Solid Wood Shelves MI = Matching Interior PTB = Plywood Toe Backer

Advantage Vanity Cabinet Standard Features and Options

The information described below discusses some of the features and options of Advantage Vanity cabinets. Customers have the option to omit these standard features as well as add other design options, which can be quickly referenced at the bottom of each page in the Vanity Cabinet Section labeled "Vanity Options Key". For more detailed descriptions and images of all available options see Options, Section 12 within this manual. The options described below are available on all Vanity cabinets unless specifically noted next to the individual cabinet as **Unavailable Options**.

Standard Shelving & Omit Shelving (OS) – 3/4" thick White Birch plywood shelving with a durable UV topcoat is standard with any Vanity cabinet with shelves. If shelving is not desired within a specific cabinet, indicate **Omit Shelving** when ordering.

5mm Shelf Holes & No Shelf Holes (NSH) – Pre-drilled 5mm shelf holes on 32mm centers are a standard feature of all Vanity cabinets with shelves. If shelf holes are not desired, indicate **No Shelf Holes** when ordering. **Note:** If shelving and shelf holes are not desired, both No Shelf Holes and Omit Shelving must be specified when ordering.

Cabinet Case Material Options – Most optional cabinet case materials will match the door, drawer front and face frame specie and are available with Vanity cabinets produced in standard Advantage species.

- **Exposed Ends (EXP)** – Matching specie veneer on the exterior face of 1/2" thick plywood cabinet sides. The interior of plywood Exposed Ends will remain as White Birch.
- **Flush Ends (FL)** – Matching specie veneer on the exterior face of 3/4" thick plywood cabinet sides. The interior of plywood Flush Ends will remain as White Birch.
- **Flush Unexposed Ends (FUE)** – Natural Birch veneer on the exterior face of the 3/4" thick flush plywood cabinet sides. Designed to be utilized when extra support is desired from non-exposed flush end panels. The interior of the plywood Flush Unexposed Ends will remain as White Birch.
- **Matching Interior (MI)** – Matching specie veneer is available on all internal cabinet parts. The Matching Interior Option is not available in combination with the Solid Wood Shelf Upgrade Option.

Solid Wood Shelf Upgrade (WS) – The **Solid Wood Shelf Upgrade** replaces the standard White Birch plywood shelving with solid wood Natural Birch shelving. Solid Wood Shelving is 3/4" thick with a bullnosed front edge and is prefinished with a UV topcoat. The Solid Wood Shelf Upgrade Option is not available in combination with the Matching Interior Option or when Vanity cabinets are deeper than 24". Solid shelving available up to 18" deep.

Dust Top (DT) - The **Dust Top Option** replaces the front and back strips at the top of the Vanity cabinet with a 1/2" thick full depth Birch plywood top. The Dust Top is machined on the right and left sides to slide into the grooves near the top of the side panels, offering additional stability to the cabinet.

Extended Stiles (EXT) – The **Extended Stile Option** provides additional width on the left, right or both stiles of the front frame. Up to 3" of additional material provides clearance between the cabinet and adjacent walls or other cabinetry allowing cabinet doors and drawers to fully open without interference. Extended stiles also provide the opportunity to scribe the frame to the wall contours during the installation process.

Leg Extension (LE) – The **Leg Extension Option** can be added to the left, right or both stiles of the front frame. When selected, the Leg Extension Option omits the toe kick from the cabinet and extends the front frame stile(s) to the floor creating a closed end panel to the cabinet.

Prep for False Door Side (PFD) – The **Prep for False Door Side Option** maintains the overall front frame width ordered, but relocates the cabinet side panel, moving it inward by 13/16" for each Prep for False Door Side selected. This creates a 3/4" reveal behind the 1-1/2" wide front frame stile to accommodate the decorative door end panel. The Prep for False Door Side Option can be ordered for the left, right or both cabinet sides. All cabinet components are automatically resized accordingly when the Prep for False Door Side Option is selected.

Square Toe Kick Notch (STN) – Standard Vanity cabinet side panels have a 3-1/2" deep x 4" high toe kick notch with a 1/4" radius at the intersecting corner. This corner can be squared with the **Square Toe Notch Option** which makes the corner notch 90° to aid in toe board installation.

Flush Toe (FT) – When selected, the **Flush Toe Option** replaces the standard recessed toe kick notches in both side panels with a 5-1/2" bottom rail on the front frame.

Shaped Bottom Rail (SBR) – The **Shaped Bottom Rail Option** automatically adds the Flush Toe to the cabinet's front frame. The 5-1/2" wide bottom rail gives customers the choice of 6 decorative shapes on the bottom rail of the Flush Toe, providing a furniture type appearance.

Shaped Side (SS) – The **Shaped Side Option** provides a choice of 4 decorative shapes on the bottom of Exposed Ends or Flush Ends. The Shaped Side Option is available on left, right, or both sides, but is not available in combination with Extended Stiles, Flushed Unexposed Ends or Loose Toe Platform.

Toe Space Side (TSS) – The **Toe Space Side Option** replaces the bottom 4" of the side panel with a recessed toe space on the left, right or both sides of most Vanity cabinets. This option is commonly used on island or peninsula cabinet sides.

VB/CSB - Vanity Base

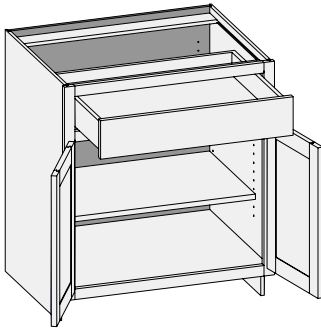

Custom Size Ranges
 Width: 12" – 36"
 Height: 31-1/2" – 42"
 Depth: 12", 15", 18", 21",
 24", 27", 30"

- When height changes, lower opening height changes. Upper opening height fixed at 5".
- Specify single or butt doors on custom size cabinets 24" wide.

21" Deep	
VB1231.5	VB1234.5
VB1531.5	VB1534.5
VB1831.5	VB1834.5
VB2131.5	VB2134.5

VS/CSBS - Vanity Sink w/Butt Doors

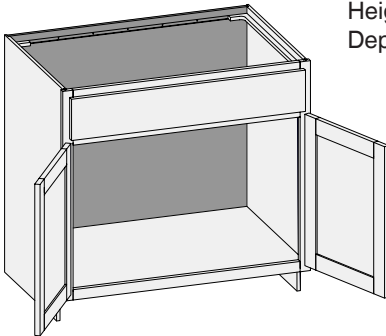

Custom Size Ranges
 Width: 24" – 36"
 Height: 31-1/2" – 42"
 Depth: 18" – 30"

- False drawer front.
- No drawer box, shelf support holes or shelf with sink units.
- When height changes, lower opening height changes. Upper opening height fixed at 5".
- Specify single or butt doors on custom size cabinets 24" wide.

21" Deep	
VS2431.5BD	VS2434.5BD
VS2731.5BD	VS2734.5BD
VS3031.5BD	VS3034.5BD
VS3331.5BD	VS3334.5BD
VS3631.5BD	VS3634.5BD

VS/CSBS2D1D - Vanity Sink Two Door One Drawer

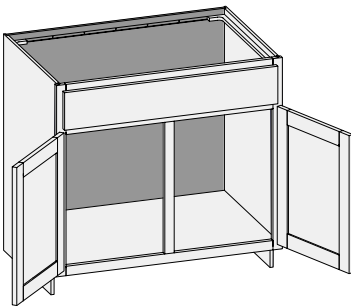

Custom Size Ranges
 Width: 27" – 36"
 Height: 31-1/2" – 42"
 Depth: 18" – 30"

- False drawer front.
- When height changes, lower opening height changes. Upper opening height fixed at 5".

21" Deep	
VS3031.5	VS3034.5
VS3331.5	VS3334.5
VS3631.5	VS3634.5

Options Key: EXP = Exposed End(s) FL = Flush End(s) FUE = Flush Unexposed End(s) SS = Shaped Side PFD = Prep for False Door
 EXT = Extended Stile(s) FT = Flush Toe LTP = Loose Toe Platform SBR = Shaped Bottom Rail LE = Leg Extension
 TSS = Toe Space Side OS = Omit Shelving NSH = No Shelf Holes WS = Solid Wood Shelves MI = Matching Interior
 DT = Dust Top NB = Natural Finished Bottom PTB = Plywood Toe Backer

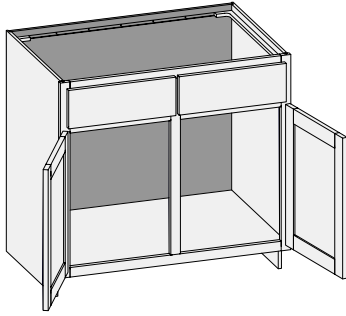
VSX/CSBS2D2D - Vanity Sink Two Door Two Drawer

Custom Size Ranges
 Width: 30" – 48"
 Height: 31-1/2" – 42"
 Depth: 18" – 30"

- False drawer fronts.
- When height changes, lower opening height changes. Upper opening height fixed at 5".

21" Deep	
VSX3031.5	VSX3034.5
VSX3631.5	VSX3634.5

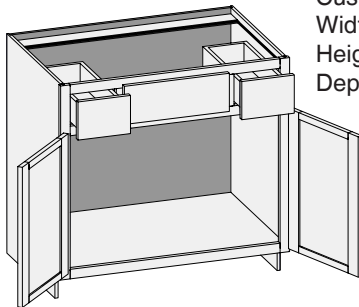
VBS/CSVBS - Vanity Base Sink w/Butt Doors

Custom Size Ranges
 Width: 36"
 Height: 31-1/2" – 42"
 Depth: 12", 15", 18", 21",
 24", 27", 30"

- False top middle drawer front.
- When height changes, lower opening height changes. Upper opening height fixed at 5".

21" Deep	
VBS3631.5BD	VBS3634.5BD

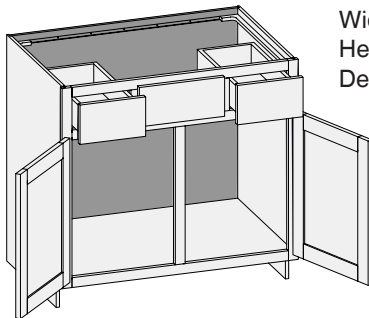
VBS/CSVBSCS - Vanity Base Sink w/Center Stile

Custom Size Ranges
 Width: 36" – 48"
 Height: 31-1/2" – 42"
 Depth: 12", 15", 18", 21",
 24", 27", 30"

- False top middle drawer front.
- When height changes, lower opening height changes. Upper opening height fixed at 5".
- When width changes, middle opening width changes. Left and right opening widths fixed at 9".

21" Deep	
VBS4231.5	VBS4234.5
VBS4831.5	VBS4834.5

Options Key: EXP = Exposed End(s) FL = Flush End(s) FUE = Flush Unexposed End(s) SS = Shaped Side PFD = Prep for False Door
 EXT = Extended Stile(s) FT = Flush Toe LTP = Loose Toe Platform SBR = Shaped Bottom Rail LE = Leg Extension
 TSS = Toe Space Side OS = Omit Shelving NSH = No Shelf Holes WS = Solid Wood Shelves MI = Matching Interior
 DT = Dust Top NB = Natural Finished Bottom PTB = Plywood Toe Backer

VSRV/CSVSRV - Vanity Sink Reverse w/Butt Doors

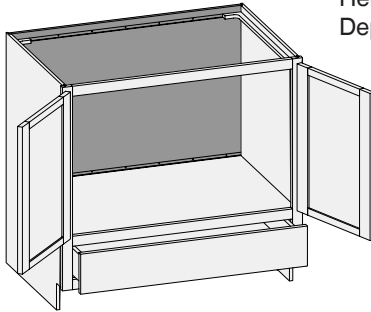

Custom Size Ranges
 Width: 24" – 36"
 Height: 31-1/2" – 42"
 Depth: 12", 15", 18", 21"
 24", 27", 30"

- When height changes, top opening height changes. Lower opening height fixed at 5".

21" Deep	
VSRV2431.5BD	VSRV2434.5BD
VSRV3031.5BD	VSRV3034.5BD
VSRV3631.5BD	VSRV3634.5BD

VSRV/CSVSRVCS - Vanity Sink Reverse w/Center Stile

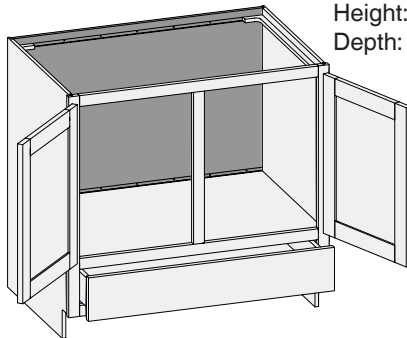

Custom Size Ranges
 Width: 30" – 36"
 Height: 31-1/2" – 42"
 Depth: 12", 15", 18", 21"
 24", 27", 30"

- When height changes, top opening height changes. Lower opening height fixed at 5".

21" Deep	
VSRV3031.5	VSRV3034.5
VSRV3631.5	VSRV3634.5

VBF/CSBFD - Vanity Base Full

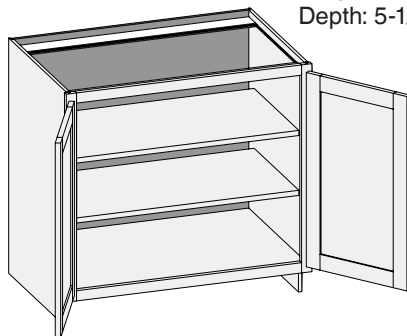

Custom Size Ranges
 Single Door Width: 9" – 24"
 Butt Door Width: 24" – 36"
 Height: 10" – 48"
 Depth: 5-1/2" – 30"

- 10" – 22" high has no shelves.
- 22-1/16" – 28" high has one shelf.
- 28-1/16" – 40" high has two shelves.
- 40-1/16" – 48" high has three shelves.
- Specify single or butt doors on custom size cabinets 24" wide.

Single Door – 21" Deep	
VBF1831.5	VBF1834.5

Butt Door Cabinet – 21" Deep	
VBF2431.5BD	VBF2434.5BD
VBF2731.5BD	VBF2734.5BD
VBF3031.5BD	VBF3034.5BD
VBF3631.5BD	VBF3634.5BD

Options Key: EXP = Exposed End(s) FL = Flush End(s) FUE = Flush Unexposed End(s) SS = Shaped Side PFD = Prep for False Door
 EXT = Extended Stile(s) FT = Flush Toe LTP = Loose Toe Platform SBR = Shaped Bottom Rail LE = Leg Extension
 TSS = Toe Space Side OS = Omit Shelving NSH = No Shelf Holes WS = Solid Wood Shelves MI = Matching Interior
 DT = Dust Top NB = Natural Finished Bottom PTB = Plywood Toe Backer

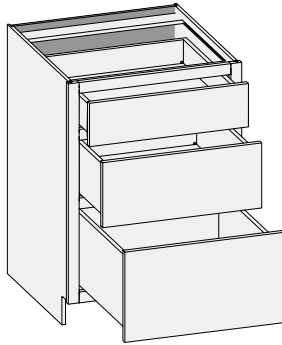
V3D/CSB3D - Vanity Three Drawer

Custom Size Ranges
 Width: 12" – 39"
 Height: 31-1/2" – 34-1/2"
 Depth: 12", 15", 18", 21"
 24", 27", 30"

- When height changes, lower opening height changes. Upper and middle opening heights fixed at 5" and 8".

21" Deep	
V3D1231.5	V3D1234.5
V3D1531.5	V3D1534.5
V3D1831.5	V3D1834.5
V3D2131.5	V3D2134.5
V3D2431.5	V3D2434.5

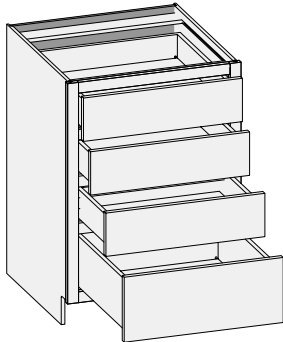
V4D/CSB4D - Vanity Four Drawer

Custom Size Ranges
 Width: 12" – 39"
 Height: 31-1/2" – 34-1/2"
 Depth: 12", 15", 18", 21"
 24", 27", 30"

- When height changes, lower opening height changes. Upper opening heights fixed at 5".

21" Deep	
V4D1231.5	V4D1234.5
V4D1531.5	V4D1534.5
V4D1831.5	V4D1834.5
V4D2131.5	V4D2134.5
V4D2431.5	V4D2434.5

Options Key: EXP = Exposed End(s) FL = Flush End(s) FUE = Flush Unexposed End(s) SS = Shaped Side PFD = Prep for False Door
 EXT = Extended Stile(s) FT = Flush Toe LTP = Loose Toe Platform SBR = Shaped Bottom Rail LE = Leg Extension
 TSS = Toe Space Side OS = Omit Shelving NSH = No Shelf Holes WS = Solid Wood Shelves MI = Matching Interior
 DT = Dust Top NB = Natural Finished Bottom PTB = Plywood Toe Backer

VCL/CSVCL - Vanity Combination Left

Custom Size Ranges
 Single Door Width: 30" – 36"
 Butt Door Width: 36" – 48"
 Height: 31-1/2" – 34-1/2"
 Depth: 12", 15", 18", 21"
 24", 27", 30"

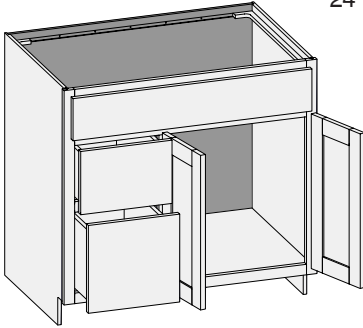

- False top drawer front.
- When height changes, lower opening heights change. Upper and middle opening heights fixed at 5" and 8".
- When width changes, door and false drawer openings change. Lower drawer openings fixed at 12".
- Specify single or butt doors on custom size cabinets 36" wide.
- Doors hinged on center stile require 1/2" overlay hinges for 1-1/4" or 1-3/8" overlays.

Single Door Cabinets – 21" Deep		Butt Door Cabinets – 21" Deep	
VCL3031.5	VCL3034.5	VCL4231.5BD	VCL4234.5BD
VCL3331.5	VCL3334.5	VCL4831.5BD	VCL4834.5BD
VCL3631.5	VCL3634.5		

VCR/CSVCR - Vanity Combination Right

Custom Size Ranges
 Single Door Width: 30" – 36"
 Butt Door Width: 36" – 48"
 Height: 31-1/2" – 34-1/2"
 Depth: 12", 15", 18", 21"
 24", 27", 30"

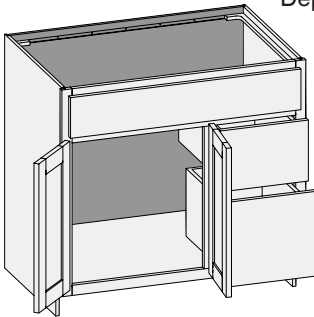

- False top drawer front.
- When height changes, lower opening heights change. Upper and middle opening heights fixed at 5" and 8".
- When width changes, door and false drawer openings change. Lower drawer openings fixed at 12".
- Specify single or butt doors on custom size cabinets 36" wide.
- Doors hinged on center stile require 1/2" overlay hinges for 1-1/4" or 1-3/8" overlays.

Single Door Cabinets – 21" Deep		Butt Door Cabinets – 21" Deep	
VCR3031.5	VCR3034.5	VCR4231.5BD	VCR4234.5BD
VCR3331.5	VCR3334.5	VCR4831.5BD	VCR4834.5BD
VCR3631.5	VCR3634.5		

VC3DL/CSV3DL - Vanity Combo Three Drawer Left

Custom Size Ranges
 Single and Butt Door
 Width: 36" – 48"
 Height: 31-1/2" – 34-1/2"
 Depth: 12", 15", 18", 21"
 24", 27", 30"

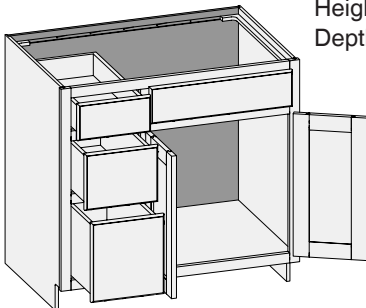

- When width changes, door and false drawer openings remain fixed.
- Doors hinged on center stile require 1/2" overlay hinges for 1-1/4" or 1-3/8" overlays.
- Specify single or butt doors on custom size cabinets.

Single Door Cabinets – 21" Deep		Butt Door Cabinets – 21" Deep	
VC3DL3631.5	VC3DL3634.5	VC3DL3631.5BD	VC3DL3634.5BD
VC3DL3931.5	VC3DL3934.5	VC3DL3931.5BD	VC3DL3934.5BD
VC3DL4231.5	VC3DL4234.5	VC3DL4231.5BD	VC3DL4234.5BD
VC3DL4531.5	VC3DL4534.5	VC3DL4531.5BD	VC3DL4534.5BD
VC3DL4831.5	VC3DL4834.5	VC3DL4831.5BD	VC3DL4834.5BD

Options Key: EXP = Exposed End(s) FL = Flush End(s) FUE = Flush Unexposed End(s) SS = Shaped Side PFD = Prep for False Door
 EXT = Extended Stile(s) FT = Flush Toe LTP = Loose Toe Platform SBR = Shaped Bottom Rail LE = Leg Extension
 TSS = Toe Space Side OS = Omit Shelving NSH = No Shelf Holes WS = Solid Wood Shelves MI = Matching Interior
 DT = Dust Top NB = Natural Finished Bottom PTB = Plywood Toe Backer

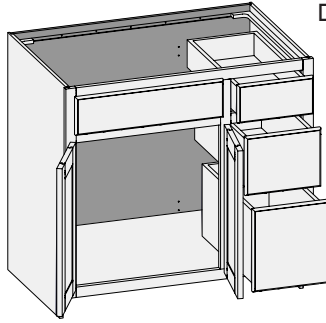
VC3DR/CSVC3DR - Vanity Combo Three Drawer Right

Custom Size Ranges
Single and Butt Door
Width: 36" – 48"
Height: 31-1/2" – 34-1/2"
Depth: 12", 15", 18", 21"
24", 27", 30"

- When width changes, door and false drawer openings remain fixed.
- When height changes, lower opening heights change. Upper and middle opening heights fixed at 5" and 8".
- Doors hinged on center stile require 1/2" overlay hinges for 1-1/4" or 1-3/8" overlays.
- Specify single or butt doors on custom size cabinets.

Single Door Cabinets – 21" Deep		Butt Door Cabinets – 21" Deep	
VC3DR3631.5	VC3DR3634.5	VC3DR3631.5BD	VC3DR3634.5BD
VC3DR3931.5	VC3DR3934.5	VC3DR3931.5BD	VC3DR3934.5BD
VC3DR4231.5	VC3DR4234.5	VC3DR4231.5BD	VC3DR4234.5BD
VC3DR4531.5	VC3DR4534.5	VC3DR4531.5BD	VC3DR4534.5BD
VC3DR4831.5	VC3DR4834.5	VC3DR4831.5BD	VC3DR4834.5BD

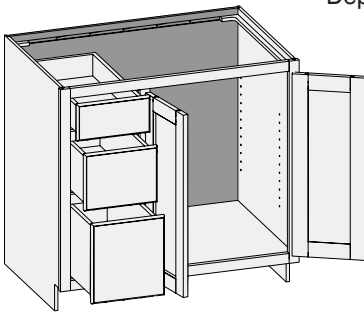
VCFD3DL/CSVCFD3DL - Vanity Combo Full Door Three Drawers Left

Custom Size Ranges
Single and Butt Door
Width: 36" – 48"
Height: 31-1/2" – 34-1/2"
Depth: 12", 15", 18", 21"
24", 27", 30"

- When width changes, door opening remains fixed.
- When height changes, lower opening heights change. Upper and middle drawer opening heights fixed at 5" and 8".
- Doors hinged on center stile require 1/2" overlay hinges for 1-1/4" or 1-3/8" overlays.
- Specify single or butt doors on custom size cabinets.

Single Door Cabinets – 21" Deep		Butt Door Cabinets – 21" Deep	
VCFD3DL3631.5	VCFD3DL3634.5	VCFD3DL3631.5BD	VCFD3DL3634.5BD
VCFD3DL3931.5	VCFD3DL3934.5	VCFD3DL3931.5BD	VCFD3DL3934.5BD
VCFD3DL4231.5	VCFD3DL4234.5	VCFD3DL4231.5BD	VCFD3DL4234.5BD
VCFD3DL4531.5	VCFD3DL4534.5	VCFD3DL4531.5BD	VCFD3DL4534.5BD
VCFD3DL4831.5	VCFD3DL4834.5	VCFD3DL4831.5BD	VCFD3DL4834.5BD

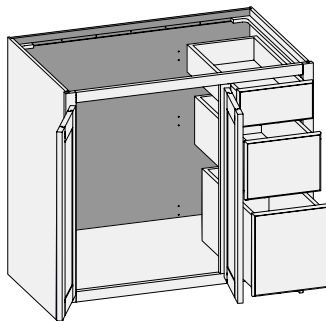
VCFD3DR/CSVCFD3DR - Vanity Combo Full Door Three Drawers Right

Custom Size Ranges
Single and Butt Door
Width: 36" – 48"
Height: 31-1/2" – 34-1/2"
Depth: 12", 15", 18", 21"
24", 27", 30"

- When width changes, door opening remains fixed.
- When height changes, lower opening heights change. Upper and middle drawer opening heights fixed at 5" and 8".
- Doors hinged on center stile require 1/2" overlay hinges for 1-1/4" or 1-3/8" overlays.
- Specify single or butt doors on custom size cabinets.

Single Door Cabinets – 21" Deep		Butt Doors Cabinets – 21" Deep	
VCFD3DR3631.5	VCFD3DR3634.5	VCFD3DR3631.5BD	VCFD3DR3634.5BD
VCFD3DR3931.5	VCFD3DR3934.5	VCFD3DR3931.5BD	VCFD3DR3934.5BD
VCFD3DR4231.5	VCFD3DR4234.5	VCFD3DR4231.5BD	VCFD3DR4234.5BD
VCFD3DR4531.5	VCFD3DR4534.5	VCFD3DR4531.5BD	VCFD3DR4534.5BD
VCFD3DR4831.5	VCFD3DR4834.5	VCFD3DR4831.5BD	VCFD3DR4834.5BD

Options Key: EXP = Exposed End(s) FL = Flush End(s) FUE = Flush Unexposed End(s) SS = Shaped Side PFD = Prep for False Door
EXT = Extended Stile(s) FT = Flush Toe LTP = Loose Toe Platform SBR = Shaped Bottom Rail LE = Leg Extension
TSS = Toe Space Side OS = Omit Shelving NSH = No Shelf Holes WS = Solid Wood Shelves MI = Matching Interior
DT = Dust Top NB = Natural Finished Bottom PTB = Plywood Toe Backer

VC6D/CSVC6D - Vanity Combination Six Drawer w/Butt Doors

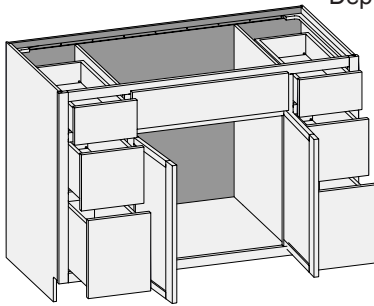

Custom Size Ranges
 Width: 48" – 72"
 Height: 31-1/2" – 34-1/2"
 Depth: 12", 15", 18", 21"
 24", 27", 30"

- One false top drawer front, two functional top drawers.
- When height changes, lower opening heights change. Upper and middle drawer openings heights fixed at 5" and 8".
- When width changes, door and false drawer front openings change.
- Doors hinged on center stile require 1/2" overlay hinges for 1-1/4" or 1-3/8" overlays.

21" Deep	
VC6D4831.5BD	VC6D4834.5BD
VC6D6031.5BD	VC6D6034.5BD

VC3D/CSVC3D - Vanity Combination Three Drawer w/Butt Doors

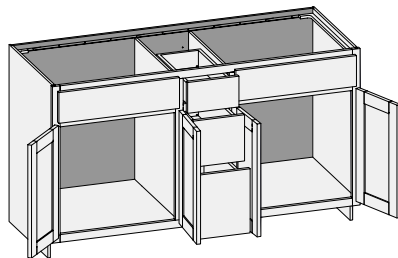

Custom Size Ranges
 Width: 48" – 72"
 Height: 31-1/2" – 34-1/2"
 Depth: 12", 15", 18", 21"
 24", 27", 30"

- Two false top drawer fronts, one functional top drawer.
- When height changes, lower opening heights change. Upper and middle drawer openings heights fixed at 5" and 8".
- When width changes, door and false drawer front openings change.
- Doors hinged on center stile require 1/2" overlay hinges for 1-1/4" or 1-3/8" overlays.

21" Deep	
VC3D6031.5BD	VC3D6034.5BD

Options Key: EXP = Exposed End(s) FL = Flush End(s) FUE = Flush Unexposed End(s) SS = Shaped Side PFD = Prep for False Door
 EXT = Extended Stile(s) FT = Flush Toe LTP = Loose Toe Platform SBR = Shaped Bottom Rail LE = Leg Extension
 TSS = Toe Space Side OS = Omit Shelving NSH = No Shelf Holes WS = Solid Wood Shelves MI = Matching Interior
 DT = Dust Top NB = Natural Finished Bottom PTB = Plywood Toe Backer

WHV/CSWHV - Wall Hung Vanity

Custom Size Ranges
 Single Door Width: 21" – 24"
 Butt Door Width: 24" – 36"
 Height: 18" – 24"
 Depth: 18" – 21"

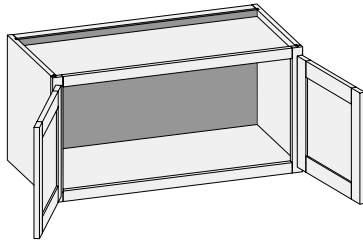

- Includes two precut 2 x 4 installation cleats.
- The load capacity of these cabinets is greatly dependent on the quality of the installation screws and whether the cabinets are secured into the wall studs. If not secured into two or more studs, using high quality installation screws the cabinet may not support the desired weight.
- Conestoga will not be responsible for cabinet failure due to inadequate installation techniques or materials.
- Specify single or butt doors on custom size cabinets 24" wide.

Single Door Cabinets 24" High	Butt Door Cabinets 24" High	
WHV2124	WHV2424BD	WHV3324BD
WHV2424	WHV2724BD	WHV3624BD
	WHV3024BD	

WHV/CSWHVCS - Wall Hung Vanity w/Center Stile

Custom Size Ranges
 Width: 27" – 48"
 Height: 18" – 24"
 Depth: 18" – 21"

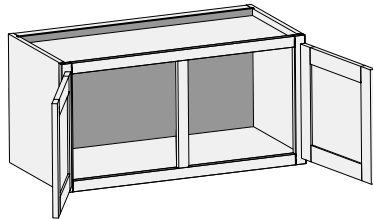

- Includes two precut 2 x 4 installation cleats.
- The load capacity of these cabinets is greatly dependent on the quality of the installation screws and whether the cabinets are secured into the wall studs. If not secured into two or more studs, using high quality installation screws the cabinet may not support the desired weight.
- Conestoga will not be responsible for cabinet failure due to inadequate installation techniques or materials.

24" High	
WHV2724	WHV3924
WHV3024	WHV4224
WHV3324	WHV4524
WHV3624	WHV4824

WHV2D/CSWHV2D - Wall Hung Vanity Two Drawers

Custom Size Ranges
 Width: 21" – 36"
 Height: 18" – 24"
 Depth: 18", 21"

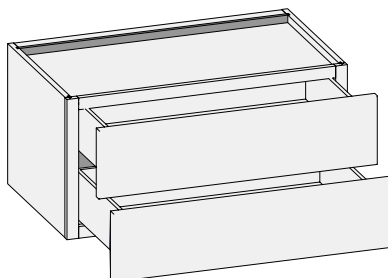

- Drawer boxes are 6" less than the depth of the cabinet to accommodate inset drawers and hardware.
- Includes two precut 2 x 4 installation cleats.
- The load capacity of these cabinets is greatly dependent on the quality of the installation screws and whether the cabinets are secured into the wall studs. If not secured into two or more studs, using high quality installation screws the cabinet may not support the desired weight.
- Conestoga will not be responsible for cabinet failure due to inadequate installation techniques or materials.

24" High	
WHV2D2124	WHV2D3024
WHV2D2424	WHV2D3324
WHV2D2724	WHV2D3624

Options Key: EXP = Exposed End(s) FL = Flush End(s) FUE = Flush Unexposed End(s) SS = Shaped Side PFD = Prep for False Door
 EXT = Extended Stile(s) FT = Flush Toe LTP = Loose Toe Platform SBR = Shaped Bottom Rail LE = Leg Extension
 TSS = Toe Space Side OS = Omit Shelving NSH = No Shelf Holes WS = Solid Wood Shelves MI = Matching Interior
 DT = Dust Top NB = Natural Finished Bottom PTB = Plywood Toe Backer

CSVLV - Vanity Linen Vanity Height

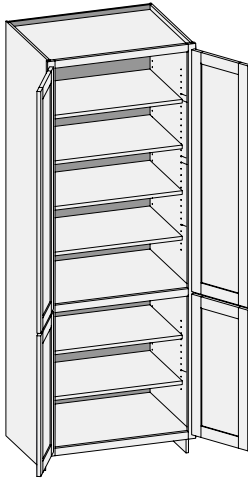

Custom Size Ranges
 Single Door Width: 12" – 24"
 Butt Door Width:
 24" – 36"
 Height: 84" – 120"
 Depth: 5-1/2" – 30"

- Lower section aligns with 31-1/2" high Vanity cabinets.
- 84" – 90" high has six shelves.
- 90-1/16" – 96" high has seven shelves.
- 96-1/16" – 108" high has eight shelves.
- 108-1/16" – 120" high has nine shelves.
- Matching specie interior is not available over 96" high. White Birch UV topcoated material will be used.
- When height changes, upper opening height changes. Lower opening height fixed at 24-1/2".
- Specify single or butt doors on custom size cabinets 24" wide.

CSUCR - Vanity Linen Base Height

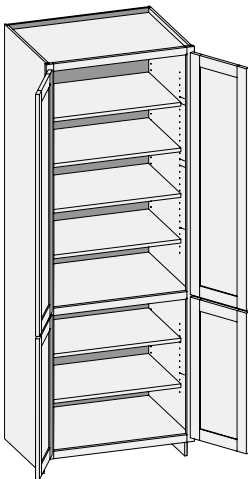

Custom Size Ranges
 Single Door Width: 12" – 24"
 Butt Door Width: 24" – 36"
 Height: 84" – 120"
 Depth: 5-1/2" – 30"

- Lower section aligns with 34-1/2" high Vanity cabinets.
- 84" – 90" high has six shelves.
- 90-1/16" – 96" high has seven shelves.
- 96-1/16" – 108" high has eight shelves.
- 108-1/16" – 120" high has nine shelves.
- Matching specie interior is not available over 96" high. White Birch UV topcoated material will be used.
- When height changes, upper opening height changes. Lower opening height fixed at 27-1/2".
- Specify single or butt doors on custom size cabinets 24" wide.

Options Key: EXP = Exposed End(s) FL = Flush End(s) FUE = Flush Unexposed End(s) SS = Shaped Side PFD = Prep for False Door
 EXT = Extended Stile(s) FT = Flush Toe LTP = Loose Toe Platform SBR = Shaped Bottom Rail LE = Leg Extension
 TSS = Toe Space Side OS = Omit Shelving NSH = No Shelf Holes WS = Solid Wood Shelves MI = Matching Interior
 DT = Dust Top NB = Natural Finished Bottom PTB = Plywood Toe Backer

CSUC - Vanity Utility

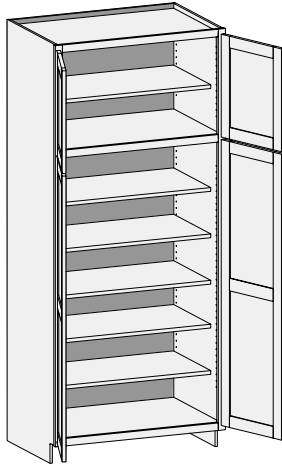

Custom Size Ranges
Single Door Width: 12" – 24"
Butt Door Width: 24" – 36"
Height: 84" – 120"
Depth: 5-1/2" – 30"

- 84" – 90" high has six shelves.
- 90-1/16" – 96" high has seven shelves.
- 96-1/16" – 108" high has eight shelves.
- 108-1/16" – 120" high has nine shelves.
- Matching specie interior is not available over 96" high. White Birch UV topcoated material will be used.
- When height changes, upper opening height changes. Lower opening height fixed at 56".
- Specify single or butt doors on custom size cabinets 24" wide.

Options Key: EXP = Exposed End(s) FL = Flush End(s) FUE = Flush Unexposed End(s) SS = Shaped Side PFD = Prep for False Door
EXT = Extended Stile(s) FT = Flush Toe LTP = Loose Toe Platform SBR = Shaped Bottom Rail LE = Leg Extension
TSS = Toe Space Side OS = Omit Shelving NSH = No Shelf Holes WS = Solid Wood Shelves MI = Matching Interior
DT = Dust Top NB = Natural Finished Bottom PTB = Plywood Toe Backer

CSVL3V - Vanity Linen Three Drawer Vanity Height

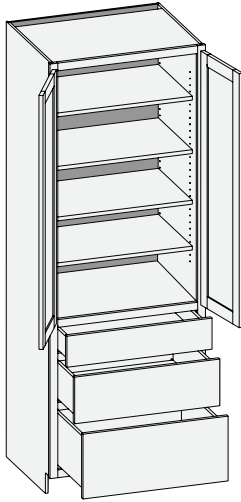

Custom Size Ranges
 Single Door Width: 12" – 24"
 Butt Door Width: 24" – 36"
 Height: 84" – 120"
 Depth: 12", 15", 18", 21"
 24", 27", 30"

- Lower section aligns with 31-1/2" high Vanity cabinets.
- 84" – 90" high has four shelves.
- 90-1/16" – 96" high has five shelves.
- 96-1/16" – 108" high has six shelves.
- 108-1/16" – 120" high has seven shelves.
- Matching specie interior is not available over 96" high. White Birch UV topcoated material will be used.
- When height changes, upper opening height changes. Lower drawer opening heights fixed at 5", 8" and 8-1/2".
- Specify single or butt doors on custom size cabinets 24" wide.

CSU3D - Vanity Linen Three Drawer Base Height

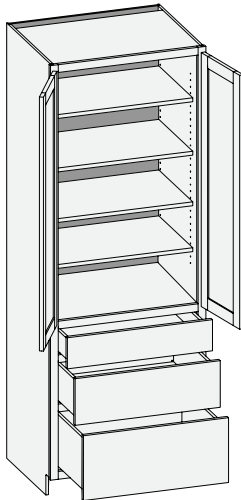

Custom Size Ranges
 Single Door Width: 12" – 24"
 Butt Door Width: 24" – 36"
 Height: 84" – 120"
 Depth: 12", 15", 18", 21"
 24", 27", 30"

- Lower section aligns with 34-1/2" high Vanity cabinets.
- 84" – 90" high has four shelves.
- 90-1/16" – 96" high has five shelves.
- 96-1/16" – 108" high has six shelves.
- 108-1/16" – 120" high has seven shelves.
- Matching specie interior is not available over 96" high. White Birch UV topcoated material will be used.
- When height changes, upper opening height changes. Lower drawer opening heights fixed at 5", 8" and 11-1/2".
- Specify single or butt doors on custom size cabinets 24" wide.

Options Key: EXP = Exposed End(s) FL = Flush End(s) FUE = Flush Unexposed End(s) SS = Shaped Side PFD = Prep for False Door
 EXT = Extended Stile(s) FT = Flush Toe LTP = Loose Toe Platform SBR = Shaped Bottom Rail LE = Leg Extension
 TSS = Toe Space Side OS = Omit Shelving NSH = No Shelf Holes WS = Solid Wood Shelves MI = Matching Interior
 DT = Dust Top NB = Natural Finished Bottom PTB = Plywood Toe Backer

VW/CSW - Vanity Wall

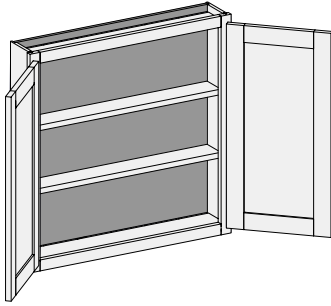

Custom Size Ranges
Width: 9" – 36"
Height: 12" – 48"
Depth: 5-1/2" – 30"

- 12" – 18" high has no shelves.
- 18-1/16" – 24" high has one shelf.
- 24-1/16" – 36" high has two shelves.
- 36-1/16" – 48" high has three shelves.
- Specify single or butt doors on custom size cabinets 24" wide.

30" High – 5-1/2" Deep	
VW1230	VW1830
VW1530	VW2430

VWS/CSVWS - Vanity Wall Shelf w/Butt Doors

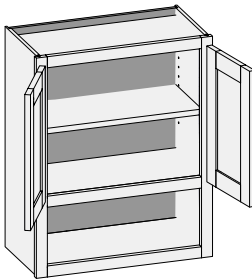

Custom Size Ranges
Width: 24" – 36"
Height: 24" – 48"
Depth: 5-1/2" – 12-1/2"

- 8" high bottom opening – fixed.
- Lower section does not match exterior specie unless Matching Interior Option is ordered.
- Specify single or butt doors on custom size cabinets 24" wide.

36" High – 8" Deep
VWS2436.5BD

Options Key: EXP = Exposed End(s) FL = Flush End(s) FUE = Flush Unexposed End(s) SS = Shaped Side PFD = Prep for False Door
EXT = Extended Stile(s) FT = Flush Toe LTP = Loose Toe Platform SBR = Shaped Bottom Rail LE = Leg Extension
TSS = Toe Space Side OS = Omit Shelving NSH = No Shelf Holes WS = Solid Wood Shelves MI = Matching Interior
DT = Dust Top NB = Natural Finished Bottom PTB = Plywood Toe Backer

Advantage Home Office/Media Cabinet Standard Features and Options

The information described below discusses some of the features and options of Advantage Home Office/Media cabinets. Customers have the option to omit these standard features as well as add other design options, which can be quickly referenced at the bottom of each page in the Home Office/Media Cabinet Section labeled "Home Office/Media Options Key". For more detailed descriptions and images of all available options see Options, Section 12 within this manual. The options described below are available on all Home Office/Media cabinets unless specifically noted next to the individual cabinet as **Unavailable Options**.

Standard Shelving & Omit Shelving (OS) – 3/4" thick White Birch plywood shelving with a durable UV topcoat is standard with any Home Office/Media cabinet with shelves. If shelving is not desired within a specific cabinet, indicate **Omit Shelving** when ordering.

5mm Shelf Holes & No Shelf Holes (NSH) – Pre-drilled 5mm shelf holes on 32mm centers are a standard feature of all Home Office/Media cabinets with shelves. If shelf holes are not desired, indicate No Shelf Holes when ordering. **Note:** If shelving and shelf holes are not desired, both No Shelf Holes and Omit Shelving must be specified when ordering.

Cabinet Case Material Options – Most optional cabinet case materials will match the door, drawer front and face frame specie and are available with Home Office/Media cabinets produced in standard Advantage species.

- **Exposed Ends (EXP)** – Matching specie veneer on the exterior face of 1/2" thick plywood cabinet sides. The interior of plywood Exposed Ends will remain as White Birch.
- **Flush Ends (FL)** – Matching specie veneer on the exterior face of 3/4" thick plywood cabinet sides. The interior of plywood Flush Ends will remain as White Birch.
- **Flush Unexposed Ends (FUE)** – Natural Birch veneer on the exterior face of the 3/4" thick flush plywood cabinet sides. Designed to be utilized when extra support is desired from non-exposed flush end panels. The interior of the plywood Flush Unexposed Ends will remain as White Birch.
- **Matching Interior (MI)** – Matching specie veneer is available on all internal cabinet parts. The **Matching Interior Option** is not available in combination with the Solid Wood Shelf Upgrade Option.

Solid Wood Shelf Upgrade (WS) – The **Solid Wood Shelf Upgrade** replaces the standard White Birch plywood shelving with solid wood Natural Birch shelving. Solid Wood Shelving is 3/4" thick with a bullnosed front edge and is prefinished with a UV topcoat. The Solid Wood Shelf Upgrade Option is not available in combination with the Matching Interior Option or when Home Office/Media cabinets are deeper than 24". Solid shelving available up to 18".

Dust Top (DT) - The **Dust Top Option** replaces the front and back strips at the top of the Home Office/Media cabinet with a 1/2" thick full depth Birch plywood top. The Dust Top is machined on the right and left sides to slide into the grooves near the top of the side panels, offering additional stability to the cabinet.

Natural Finished Bottom Option (NB) – The **Natural Finished Bottom Option** provides a UV topcoat on the exterior of the top and bottom of the Home Office/Media cabinets. When the Natural Finished Bottom Option is selected, the cabinet top and bottom exteriors will be upgraded to a White Birch plywood.

Extended Stiles (EXT) – The **Extended Stile Option** provides additional width on the left, right or both stiles of the front frame. Up to 3" of additional material provides clearance between the cabinet and adjacent walls or other cabinetry allowing cabinet doors and drawers to fully open without interference. Extended stiles also provide the opportunity to scribe the frame to the wall contours during the installation process.

Leg Extensions (LE) – the **Leg Extensions Option** can be added to the left, right or both stiles of the front frame. When selected, the Leg Extension Option omits the toe kick from the cabinet and extends the front frame stile(s) to the floor creating a closed end panel to the cabinet.

Prep For False Door Side (PFD) – The **Prep for False Door Side Option** maintains the overall front frame width ordered, but relocates the cabinet side panel, moving it inward by 13/16" for each Prep for False Door Side selected. This creates a 3/4" reveal behind the 1-1/2" wide front frame stile to accommodate the decorative door end panel. The Prep for False Door Side Option can be ordered for the left, right or both cabinet sides. All cabinet components are automatically resized accordingly when the Prep for False Door Side Option is selected.

Advantage Home Office/Media Cabinet Standard Features and Options (continued)

Square Toe Kick Notch (STN) – Standard Media Center cabinet side panels have a 3-1/2” deep x 4” high toe kick notch with a 1/4” radius at the intersecting corner. This corner can be squared with the **Square Toe Notch Option** which makes the corner notch 90° to aid in toe kick installation. The Square Toe Kick Notch Option is not available with Home Office cabinetry.

Flush Toe (FT) – When selected, the **Flush Toe Option** replaces the standard recessed toe kick notches in both side panels with a 5-1/2” bottom rail on the front frame. The Flush Toe Option is not available with Home Office cabinetry, but is available with Media Center cabinetry.

Shaped Bottom Rail (SBR) – The **Shaped Bottom Rail Option** automatically adds the Flush Toe to the cabinet’s front frame. The 5-1/2” wide bottom rail gives customers the choice of 6 decorative shapes on the bottom rail of the Flush Toe, providing a furniture type appearance. The Shaped Bottom Rail Option is not available with Home Office cabinetry, but is available with Media Center cabinetry.

Shaped Side (SS) – The **Shaped Side Option** provides a choice of 4 decorative shapes on the bottom of Exposed Ends or Flush Ends. The Shaped Side Option is available on left, right or both sides, but is not available in combination with Extended Stiles, Flushed Unexposed Ends or Loose Toe Platform. The Shaped Side Option is not available with Home Office cabinetry, but is available with Media Center cabinetry.

Toe Space Side (TSS) – The **Toe Space Side Option** replaces the bottom 4” of the side panel with a recessed toe space on the left, right or both sides of most Home Office/Media cabinets. This option is commonly used on island or peninsula cabinet sides.

DB/CSDB - Desk Base

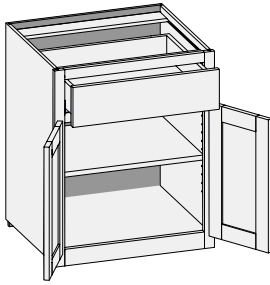

2-1/2" Bottom Rail

Custom Size Ranges
 Single Door Width: 12" – 24"
 Butt Door Width: 24" – 36"
 Height: 29-1/2"
 Depth: 18", 21", 24"

- Specify single or butt doors on custom size cabinets 24" wide.
- 2-1/2" high Flush Toe standard.
- Unavailable Options: SS, SBR, LE, TSS and NB.

Single Door Cabinets – 24" Deep		Butt Door Cabinet –24" Deep
DB1229.5	DB2129.5	DB2429.5BD
DB1529.5	DB2429.5	
DB1829.5		

DBFD/CSDBFD - Desk Base Full Door

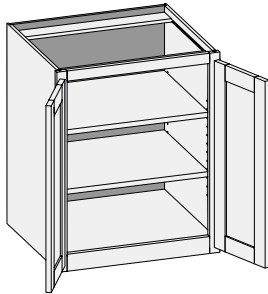

2-1/2" Bottom Rail

Custom Size Ranges
 Single Door Width: 12" – 24"
 Butt Door Width: 24" – 36"
 Height: 29-1/2"
 Depth: 18" – 30"

- Specify single or butt doors on custom size cabinets 24" wide.
- 2-1/2" high Flush Toe standard.
- Unavailable Options: SS, SBR, LE, TSS and NB.

Single Door Cabinets – 24" Deep		Butt Door Cabinet – 24" Deep
DBFD1229.5	DBFD2129.5	DBFD2429.5BD
DBFD1529.5	DBFD2429.5	
DBFD1829.5		

DB2D/CSDB2D - Desk Base Two Drawers

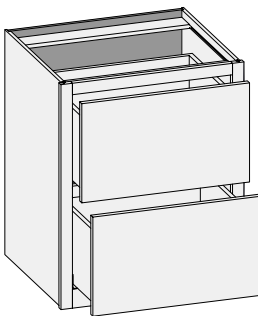

2-1/2" Bottom Rail

Custom Size Ranges
 Width: 12" – 36"
 Height: 29-1/2"
 Depth: 18", 21", 24"

- Both drawers designed to accommodate Pendaflex files.
- 15" width Pendaflex files must be installed front to back.
- 2-1/2" high Flush Toe standard.
- Unavailable Options: SS, SBR, LE, TSS and NB.

24" Deep	
DB2D1529.5	DB2D2129.5
DB2D1829.5	

Options Key: EXP = Exposed End(s) FL = Flush End(s) FUE = Flush Unexposed End(s) SS = Shaped Side PFD = Prep for False Door
 EXT = Extended Stile(s) FT = Flush Toe SBR = Shaped Bottom Rail LE = Leg Extension TSS = Toe Space Side OS = Omit Shelving
 NSH = No Shelf Holes WS = Solid Wood Shelves MI = Matching Interior DT = Dust Top NB = Natural Finished Bottom
 PTB = Plwood Toe Backer

LF2D/CSLF2D - Lateral File Two Drawer

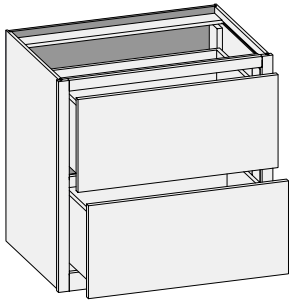

2-1/2" Bottom Rail

Custom Size Ranges
Width: 30" – 36"
Height: 29-1/2"
Depth: 21"

- Full extension interlocking drawer slides only.
- 2-1/2" high Flush Toe standard.
- Unavailable Options: SS, SBR, LE and TSS.

21" Deep	
LF2D3029.5	LF2D3629.5

DB3D/CSDB3D - Desk Base Three Drawers

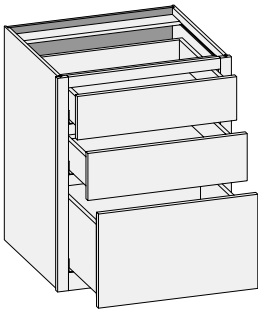

2-1/2" Bottom Rail

Custom Size Ranges
Width: 12" – 36"
Height: 29-1/2"
Depth: 18", 21", 24"

- Bottom drawer designed to accommodate Pendaflex files.
- 15" width Pendaflex files must be installed front to back.
- 2-1/2" high Flush Toe standard.
- Unavailable Options: SS, SBR, LE and TSS.

24" Deep	
DB3D1529.5	DB3D2129.5
DB3D1829.5	DB3D2429.5

DD/CSDD - Desk Drawer

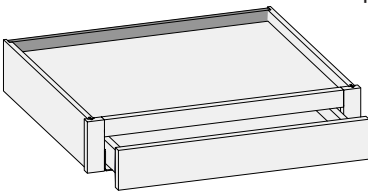

Custom Size Ranges
Width: 12" – 36"
Height: 4-1/2"
Depth: 18", 21", 24"

- No bottom or bottom rail.
- Unavailable Options: SS, PFD and LE.

24" Deep	
DD184.5	DD304.5
DD214.5	DD334.5
DD244.5	DD364.5
DD274.5	

DDSL (R)/CSDDSL (R) - Desk Drawer Support Left (or Right)

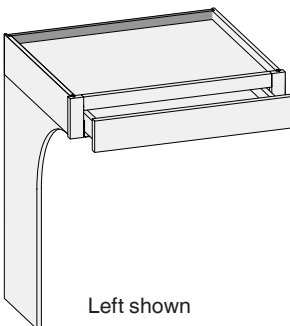

Left shown

Custom Size Ranges
Height: 29-1/2" – 42"
Depth: 18", 21", 24"

- Support leg only.
- Replaces left or right side of desk drawer.
- Bottom can be trimmed to custom height.
- Exposed edge is banded with matching specie veneer.
- Unavailable Options: SS, PFD, EXT and LE.

24" Deep	
DDSL2134.5	DDSR2134.5
DDSL2434.5	DDSR2434.5

Options Key: EXP = Exposed End(s) FL = Flush End(s) FUE = Flush Unexposed End(s) SS = Shaped Side PFD = Prep for False Door
EXT = Extended Stile(s) FT = Flush Toe SBR = Shaped Bottom Rail LE = Leg Extension TSS = Toe Space Side OS = Omit Shelving
NSH = No Shelf Holes WS = Solid Wood Shelves MI = Matching Interior DT = Dust Top NB = Natural Finished Bottom
PTB = Plwood Toe Backer

LFS/CSLFS - Letter File Slot

Custom Size Ranges
Width: 24" – 29-15/16"
Height: 6"
Depth: 12-1/2"

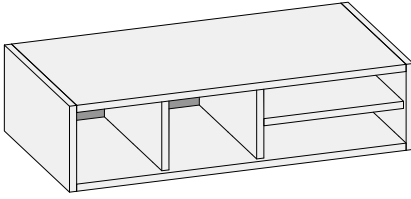

- 1/2" matching specie doweled plywood construction.
- Recessed back design for custom depth modification.
- Exposed edges are banded with matching specie veneer.
- When width changes, vertical openings change.
- No options available.

12-1/2" Deep	
LFS246	LFS276

LFS/CSLFS - Letter File Slot

Custom Size Ranges
Width: 30" – 32-15/16"
Height: 6"
Depth: 12-1/2"

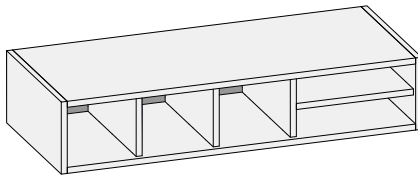

- 1/2" matching specie doweled plywood construction.
- Recessed back design for custom depth modification.
- Exposed edges are banded with matching specie veneer.
- When width changes, vertical openings change.
- No options available.

12-1/2" Deep	
LFS306	

LFS/CSLFS - Letter File Slot

Custom Size Ranges
Width: 33" – 38-15/16"
Height: 6"
Depth: 12-1/2"

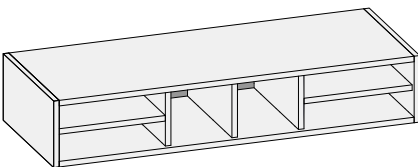

- 1/2" matching specie doweled plywood construction.
- Recessed back design for custom depth modification.
- Exposed edges are banded with matching specie veneer.
- When width changes, vertical openings change.
- No options available.

12-1/2" Deep	
LFS336	LFS366

LFS/CSLFS - Letter File Slot

Custom Size Ranges
Width: 39" – 44-15/16"
Height: 6"
Depth: 12-1/2"

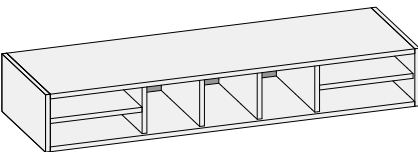

- 1/2" matching specie doweled plywood construction.
- Recessed back design for custom depth modification.
- Exposed edges are banded with matching specie veneer.
- When width changes vertical, openings change.
- No options available.

12-1/2" Deep	
LFS396	LFS426

Options Key: EXP = Exposed End(s) FL = Flush End(s) FUE = Flush Unexposed End(s) SS = Shaped Side PFD = Prep for False Door
 EXT = Extended Stile(s) FT = Flush Toe SBR = Shaped Bottom Rail LE = Leg Extension TSS = Toe Space Side OS = Omit Shelving
 NSH = No Shelf Holes WS = Solid Wood Shelves MI = Matching Interior DT = Dust Top NB = Natural Finished Bottom
 PTB = Plywood Toe Backer

LFS/CSLFS - Letter File Slot

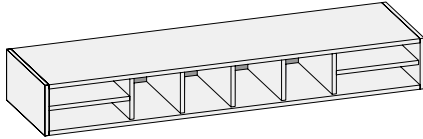

Custom Size Ranges
 Width: 45" – 48"
 Height: 6"
 Depth: 12-1/2"

- 1/2" matching specie doweled plywood construction.
- Recessed back design for custom depth modification.
- Exposed edges are banded with matching specie veneer.
- When width changes, vertical openings change.
- No options available.

12-1/2" Deep	
LFS456	LFS486

ORC/CSORC - Other Room Cabinet

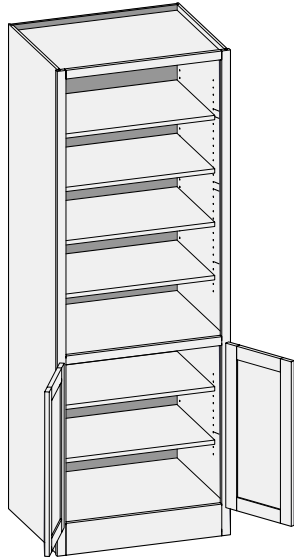

Custom Size Ranges
 Single Door Width: 12" – 24"
 Butt Door Width: 24" – 36"
 Height: 84" – 120"
 Depth: 5-1/2" – 30"

- 5-1/2" Flush Toe standard.
- Matching specie interior is not available over 96" high. White Birch UV topcoated material will be used.
- Doors on top section are optional and must be specified.
- Lower section aligns with 34-1/2" high base cabinets.
- When height changes, upper opening height changes. Lower opening height fixed at 27-1/2".
- 84" – 90" high has six shelves.
- 90-1/16" – 96" high has seven shelves.
- 96-1/16" – 108" high has eight shelves.
- 108-1/16" – 120" high has nine shelves.
- Specify single or butt doors on custom size cabinets 24" wide.
- Unavailable options: SS, SBR and TSS.

ORS/CSORS - Other Room Shelf

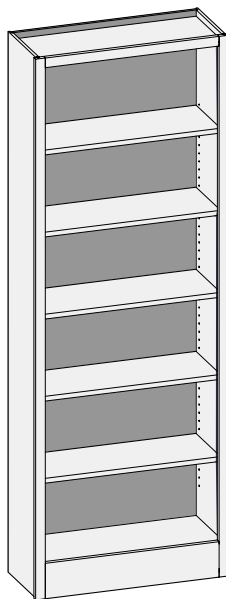

Custom Size Ranges
 Width: 12" – 36"
 Height: 84" – 120"
 Depth: 5-1/2" – 30"

- 5-1/2" Flush Toe standard.
- Matching specie interior is not available over 96" high. White Birch UV topcoated material will be used.
- 84" – 90" high has six shelves.
- 90-1/16" – 96" high has seven shelves.
- 96-1/16" – 108" high has eight shelves.
- 108-1/16" – 120" high has nine shelves.
- Unavailable options: SS, SBR and TSS.

Options Key: EXP = Exposed End(s) FL = Flush End(s) FUE = Flush Unexposed End(s) SS = Shaped Side PFD = Prep for False Door
 EXT = Extended Stile(s) FT = Flush Toe SBR = Shaped Bottom Rail LE = Leg Extension TSS = Toe Space Side OS = Omit Shelving
 NSH = No Shelf Holes WS = Solid Wood Shelves MI = Matching Interior DT = Dust Top NB = Natural Finished Bottom
 PTB = Plywood Toe Backer

W1D/CSW1D - Wall One Drawer

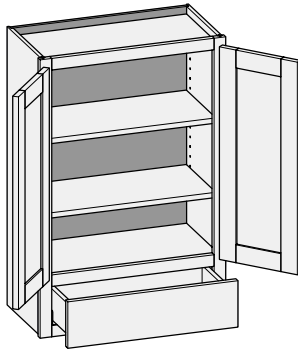

Custom Size Ranges
 Single Door Width: 12" – 24"
 Butt Door Width: 24" – 36"
 Height: 30" – 72"
 Depth: 12", 12-1/2",
 15", 18", 21", 24"

- When height changes, upper opening height changes. Lower opening height fixed at 5".
- 30" – 35-15/16" high has one shelf.
- 36" – 47-15/16" high has two shelves.
- 48" – 59-15/16" high has three shelves.
- 60" – 72" high has four shelves.
- Specify single or butt doors on custom size cabinets 24" wide.
- Unavailable options: PFD, SS, FT, SBR, LE, TSS, DT.

Single Door Cabinets – 12-1/2" Deep			Butt Door Cabinets – 12-1/2" Deep		
53" High	59" High	65" High	53" High	59" High	65" High
W1D1553	W1D1559	W1D1565	W1D2453BD	W1D2459BD	W1D2465BD
W1D1853	W1D1859	W1D1865	W1D2753BD	W1D2759BD	W1D2765BD
W1D2153	W1D2159	W1D2165	W1D3053BD	W1D3059BD	W1D3065BD
W1D2453	W1D2459	W1D2465	W1D3353BD	W1D3359BD	W1D3365BD
			W1D3653BD	W1D3659BD	W1D3665BD

CSW1DCS - Wall One Drawer w/Center Stile

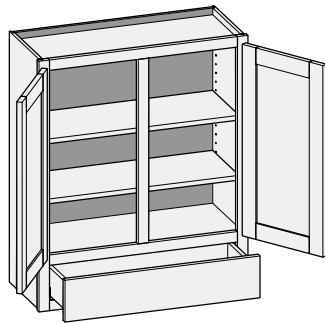

Custom Size Ranges
 Width: 27" – 36"
 Height: 30" – 72"
 Depth: 12", 12-1/2",
 15", 18", 21", 24"

- When height changes, upper opening height changes. Lower opening height fixed at 5".
- 30" – 35-15/16" high has one shelf.
- 36" – 47-15/16" high has two shelves.
- 48" – 59-15/16" high has three shelves.
- 60" – 72" high has four shelves.
- Specify single or butt doors on custom size cabinets 24" wide.
- Unavailable options: PFD, SS, FT, SBR, LE, TSS, DT.

W2D/CSW2D - Wall Two Drawer

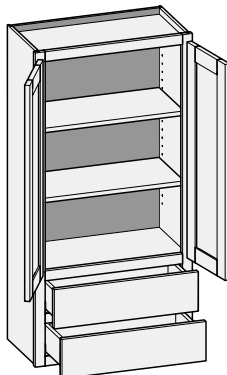

Custom Size Ranges
 Single Door Width: 12" – 24"
 Butt Door Width: 24" – 36"
 Height: 30" – 72"
 Depth: 12", 12-1/2",
 15", 18", 21", 24"

- When height changes, upper opening height changes. Lower opening heights fixed at 5".
- 30" – 41-15/16" high has one shelf.
- 42" – 47-15/16" high has two shelves.
- 48" – 59-15/16" high has three shelves.
- 60" – 72" high has four shelves.
- Specify single or butt doors on custom size cabinets 24" wide.
- Unavailable options: PFD, SS, FT, SBR, LE, TSS, DT.

Single Door Cabinets – 12-1/2" Deep			Butt Door Cabinets – 12-1/2" Deep		
53" High	59" High	65" High	53" High	59" High	65" High
W2D1553	W2D1559	W2D1565	W2D2453BD	W2D2459BD	W2D2465BD
W2D1853	W2D1859	W2D1865	W2D2753BD	W2D2759BD	W2D2765BD
W2D2153	W2D2159	W2D2165	W2D3053BD	W2D3059BD	W2D3065BD
W2D2453	W2D2459	W2D2465	W2D3353BD	W2D3359BD	W2D3365BD
			W2D3653BD	W2D3659BD	W2D3665BD

Options Key: EXP = Exposed End(s) FL = Flush End(s) FUE = Flush Unexposed End(s) SS = Shaped Side PFD = Prep for False Door
 EXT = Extended Stile(s) FT = Flush Toe SBR = Shaped Bottom Rail LE = Leg Extension TSS = Toe Space Side OS = Omit Shelving
 NSH = No Shelf Holes WS = Solid Wood Shelves MI = Matching Interior DT = Dust Top NB = Natural Finished Bottom
 PTB = Plwood Toe Backer

CSW2DCS - Wall Two Drawer w/Center Stile

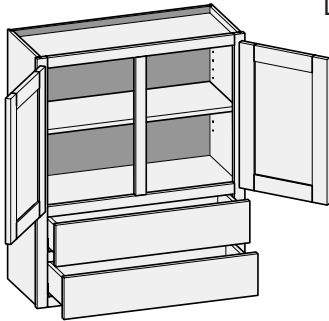

Custom Size Ranges
 Width: 27" – 36"
 Height: 30" – 72"
 Depth: 12", 12-1/2",
 15", 18", 21", 24"

- When height changes, upper opening height changes. Lower opening heights fixed at 5".
- 30" – 41-15/16" high has one shelf.
- 42" – 47-15/16" high has two shelves.
- 48" – 59-15/16" high has three shelves.
- 60" – 72" high has four shelves.
- Specify single or butt doors on custom size cabinets 24" wide.
- Unavailable options: PFD, SS, EXT, FT, SBR, LE, TSS, DT.

WOBS/CSWOBS - Wall Open Bookshelf

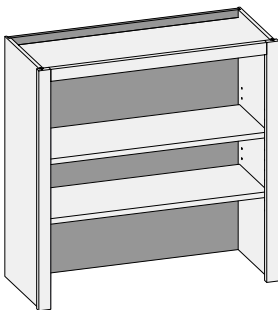

Custom Size Ranges
 Width: 15" – 36"
 Height: 30" – 72"
 Depth: 5-1/2" – 27"

- Solid wood shelves not available with matching specie interior option.
- 30" – 35-15/16" high has one shelf.
- 36" – 47-15/16" high has two shelves.
- 48" – 59-15/16" high has three shelves.
- 60" – 72" high has four shelves.

12-1/2" Deep		
53" High	59" High	65" High
WOBS1553	WOBS1559	WOBS1565
WOBS1853	WOBS1859	WOBS1865
WOBS2153	WOBS2159	WOBS2165
WOBS2453	WOBS2459	WOBS2465
WOBS2753	WOBS2759	WOBS2765
WOBS3053	WOBS3059	WOBS3065
WOBS3353	WOBS3359	WOBS3365
WOBS3653	WOBS3659	WOBS3665

WOBSCS/CSWOBSCS - Wall Open Bookshelf w/Center Stile

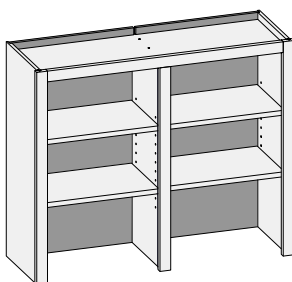

Custom Size Ranges
 Width: 15" – 36"
 Height: 30" – 72"
 Depth: 5-1/2" – 27"

- Fixed vertical partition with independently adjustable shelves.
- Solid wood shelves not available with matching specie interior option.
- 30" – 35-15/16" high has two shelves.
- 36" – 47-15/16" high has four shelves.
- 48" – 59-1/16" high has six shelves.
- 60" – 72" high has eight shelves.

Options Key: EXP = Exposed End(s) FL = Flush End(s) FUE = Flush Unexposed End(s) SS = Shaped Side PFD = Prep for False Door
 EXT = Extended Stile(s) FT = Flush Toe SBR = Shaped Bottom Rail LE = Leg Extension TSS = Toe Space Side OS = Omit Shelving
 NSH = No Shelf Holes WS = Solid Wood Shelves MI = Matching Interior DT = Dust Top NB = Natural Finished Bottom
 PTB = Plwood Toe Backer

MC2FD/CSMC2FD - Media Center Two Full Doors

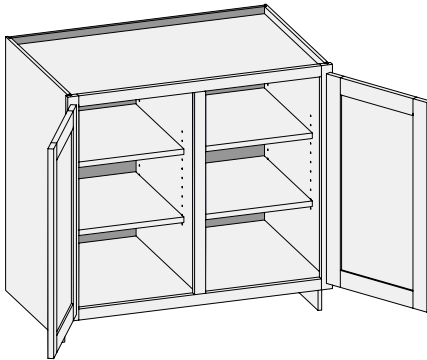

Custom Size Ranges
 Width: 30" – 48"
 Height: 10" – 48"
 Depth: 5-1/2" – 30"

- Fixed vertical partition with independently adjustable shelves.
- 10" – 22" high has no shelves.
- 22-1/16" – 28" high has one shelf.
- 28-1/16" – 40" high has two shelves.
- 40-1/16" – 48" high has three shelves.
- Unavailable options: PFD and TSS.

MC3FD/CSMC3FD - Media Center Three Full Doors

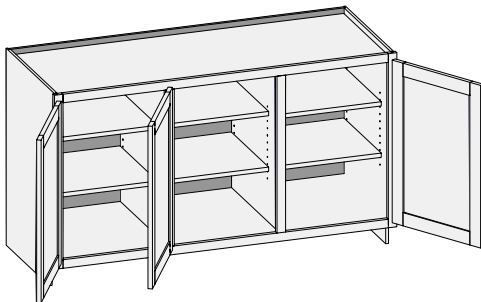

Custom Size Ranges
 Width: 48" – 72"
 Height: 10" – 48"
 Depth: 5-1/2" – 30"

- Fixed vertical partitions with independently adjustable shelves.
- Doors hinged on center style require 1/2" overlay hinges for 1-1/4" and 1-3/8" overlays.
- 10" – 22" high has no shelves.
- 22-1/16" – 28" high has one shelf.
- 28-1/16" – 40" high has two shelves.
- 40-1/16" – 48" high has three shelves.
- Unavailable options: PFD and TSS.

MC2D/CSMC2D - Media Center Two Door

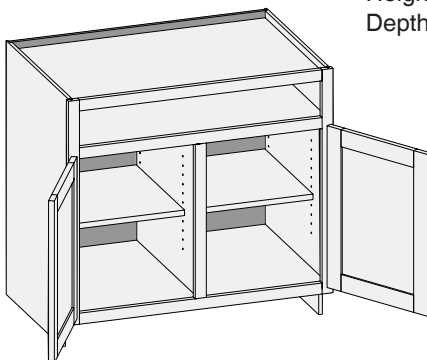

Custom Size Ranges
 Width: 30" – 48"
 Height: 31-1/2" – 42"
 Depth: 5-1/2" – 30"

- Fixed vertical partition with independently adjustable shelves.
- When height changes, lower opening height changes. Upper opening height fixed at 5".
- Unavailable options: PFD and TSS.

Options Key: EXP = Exposed End(s) FL = Flush End(s) FUE = Flush Unexposed End(s) SS = Shaped Side PFD = Prep for False Door
 EXT = Extended Stile(s) FT = Flush Toe SBR = Shaped Bottom Rail LE = Leg Extension TSS = Toe Space Side OS = Omit Shelving
 NSH = No Shelf Holes WS = Solid Wood Shelves MI = Matching Interior DT = Dust Top NB = Natural Finished Bottom
 PTB = Plwood Toe Backer

MC3D/CSMC3D - Media Center Three Door

Custom Size Ranges
 Width: 48" – 72"
 Height: 31-1/2" – 42"
 Depth: 5-1/2" – 30"

- Fixed vertical partitions with independently adjustable shelves.
- When height changes, lower opening height changes. Upper opening height fixed at 5".
- Doors hinged on center style require 1/2" overlay hinges for 1-1/4" and 1-3/8" overlays.
- Unavailable options: PFD and TSS.

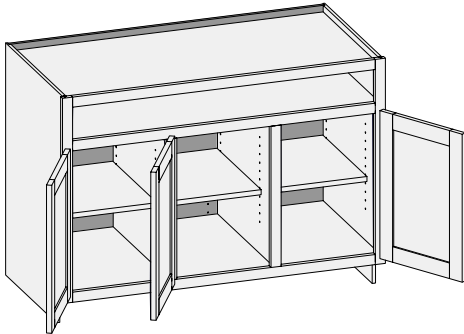

MC2D2D/CSMC2D2D - Media Center Two Door Two Drawer

Custom Size Ranges
 Width: 48" – 72"
 Height: 31-1/2" – 42"
 Depth: 12", 15", 18",
 21", 24", 27",
 30"

- Fixed vertical partitions with independently adjustable shelves.
- When height changes, lower opening height changes. Upper opening height fixed at 5". Middle opening height fixed at 8".
- Unavailable options: PFD and TSS.

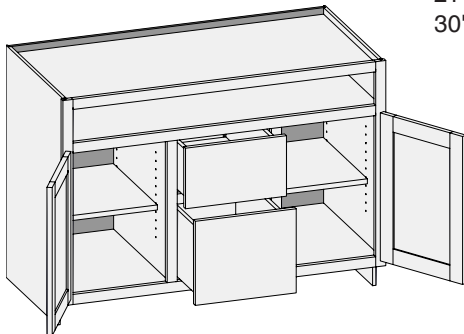

MC2D3D/CSMC2D3D - Media Center Two Door Three Drawer

Custom Size Ranges
 Width: 48" – 72"
 Height: 31-1/2" – 34-1/2"
 Depth: 12", 15", 18",
 21", 24", 27", 30"

- Fixed vertical partitions with independently adjustable shelves.
- When height changes, lower opening height changes. Upper opening height fixed at 5". Middle opening height fixed at 8".
- Unavailable options: PFD and TSS.

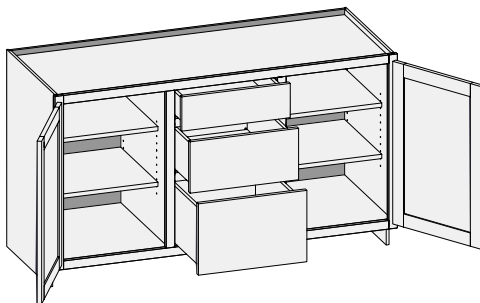

Options Key: EXP = Exposed End(s) FL = Flush End(s) FUE = Flush Unexposed End(s) SS = Shaped Side PFD = Prep for False Door
 EXT = Extended Stile(s) FT = Flush Toe SBR = Shaped Bottom Rail LE = Leg Extension TSS = Toe Space Side OS = Omit Shelving
 NSH = No Shelf Holes WS = Solid Wood Shelves MI = Matching Interior DT = Dust Top NB = Natural Finished Bottom
 PTB = Plwood Toe Backer

DWEP/REP/CSEP - Dishwasher/Refrigerator End Panel

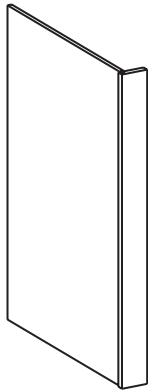

Custom Size Ranges
 Width: 1-1/2" & 3"
 Height: 12" – 120"
 Depth: 5-1/2" – 30"

- 1-1/2" or 3" stile.
- Matching specie veneer standard on both sides, except when height exceeds 96", where Natural Birch UV topcoated material will be used.
- Options: Flush Ends (FL) and Prep False Door (PFD).

24" Deep		
34-1/2" High	84" High	96" High
DWEP2434.5	REP2484	REP2496
	REP2784	REP2796

FS/CSFSW - Filler Strip (Wall)

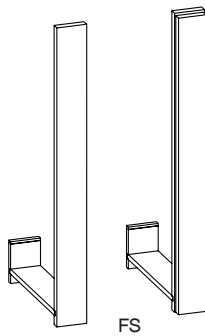

CSFSW (with overlay)

Custom Size Ranges
 Width: 3" and 6" only
 Height: 12" – 72"
 Depth: 5-1/2" – 27"

- Solid wood front strip.
- One-piece overlays are available with 1-1/4" and 1-3/8" overlay.
- Overlay will have a Machine Edge on one long side and matching door edge on three sides.
- If overlay is required, order a CSFSW (Custom Size Filler Strip Wall).

12-1/2" Deep	
30" High	42" High
FS0330	FS0342
FS0630	FS0642

FS/CSFSB - Filler Strip (Base)

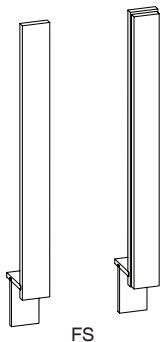

CSFSB (with overlay)

Custom Size Ranges
 Width: 3" and 6" only
 Height: 31-1/2" – 96"
 Depth: 4"

- Solid wood front strip.
- One-piece overlays are available with 1-1/4" and 1-3/8" overlay.
- Overlay will have a Machine Edge on one long side and matching door edge on three sides.
- If overlay is required, order a CSFSB (Custom Size Filler Strip Base).

34-1/2" High	84" High	96" High
FS0334.5	FS0384	FS0396
FS0634.5	FS0684	FS0696

WFC/CSWFC - Wall Filler Columns

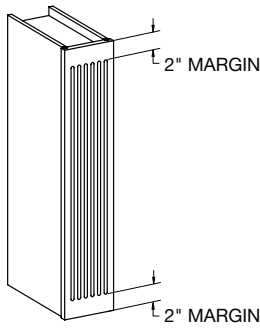

Custom Size Ranges
 Width: 3" & 6" only
 Height: 12" – 65"
 Depth: 5-1/2" – 30"

- Specify either Tapered, Rounded or No Flutes.
- 3" column has three flutes.
- 6" column has six flutes.
- Options: Exposed Ends (EXP), Flush Ends (FL), Flush Unexposed Ends (FUE).

BFC/TFC/CSBFC - Base Filler Columns/Tall Filler Columns

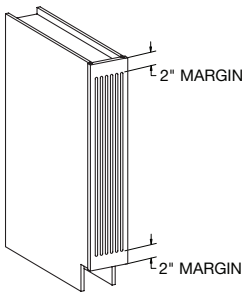

Standard Toe

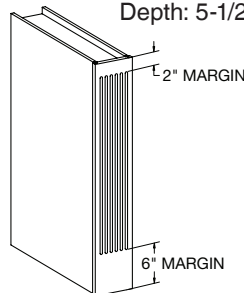

Flush Toe

Custom Size Ranges
 Width: 3" & 6" only
 Height: 31-1/2" – 96"
 Depth: 5-1/2" – 30"

- Specify either Tapered, Rounded or No Flutes.
- 3" column has three flutes.
- 6" column has six flutes.
- Options: Exposed Ends (EXP), Flush Ends (FL), Flush Unexposed Ends (FUE), Flush Toe (FT).

24" Deep	
31-1/2" High	34-1/2" High
BFC0331.5	BFC0334.5
BFC0631.5	BFC0634.5

ZAF(L)/CSZAF(L) - Zero Angle Filler Left (or Right)

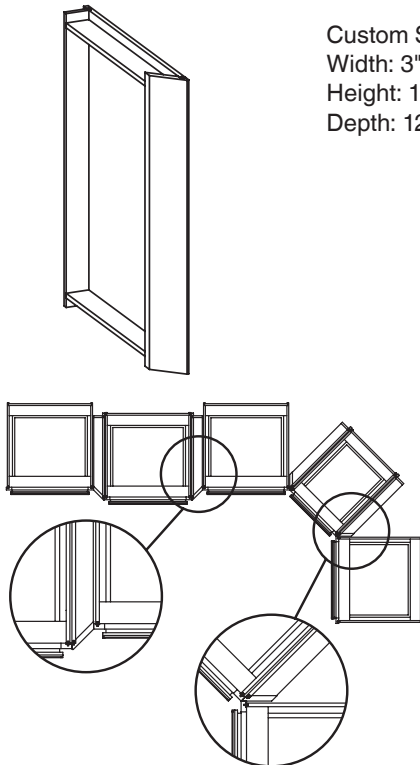

Custom Size Ranges
 Width: 3" only
 Height: 12" – 120"
 Depth: 12-1/2" – 24"

- Designed to turn 135° corners with standard cabinets or to facilitate breakfront designs.
- No toe kick; use 30-1/2" high unit for standard Base applications with toe kicks or specify CS unit at 34-1/2" high when flush toe is required.
- Non-fluted face is standard; 3 flutes spaced evenly on angled face are optional. Specify tapered or rounded flutes. If not specified, flutes will be produced using the tapered design.
- Flute spacing is fixed, no option:
 - ZAF heights 30" – 42" have 2" spacing top and bottom.
 - ZAF heights 84" – 90" have 2" top spacing – specify 2" or 6" bottom spacing.

24" Deep	
ZAF(L)0330	ZAF(R)0342
ZAF(R)0330	ZAF(L)0384
ZAF(L)0330.5	ZAF(R)0384
ZAF(R)0330.5	ZAF(L)0390
ZAF(L)0336	ZAF(R)0390
ZAF(R)0336	ZAF(L)0396
ZAF(L)0342	ZAF(R)0396

WSU/CSWSUW - Wine Storage Unit

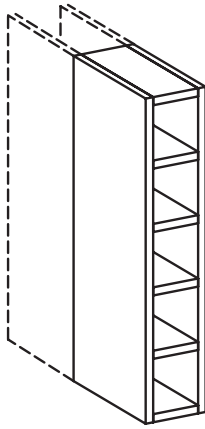

Custom Size Ranges
Width: 6" only
Height: 30", 36", 42"
Depth: 12-1/2" – 27"

- 3/4" matching specie plywood with dowel construction.
- Exposed edges are banded with matching specie veneer.
- Hard Maple plywood used for Hard and Soft Maple species.
- 30" high has five openings.
- 36" high has six openings.
- 42" high has seven openings.
- 11-3/4" interior depth. When ordered deeper than 12-1/2" sides extend past back.

12-1/2" Deep	
WSU0630	WSU0642
WSU0636	

WSUD/CSWSUB - Wine Storage Unit Deep

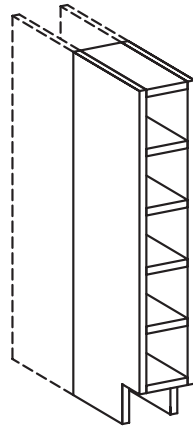

Custom Size Ranges
Width: 6" only
Height: 34-1/2" only
Depth: 12-1/2" – 30"

- 3/4" matching specie plywood with dowel construction.
- Exposed edges are banded with matching specie veneer.
- Hard Maple plywood used for Hard and Soft Maple species.
- 11-3/4" interior depth. When ordered deeper than 12-1/2" sides extend past back.

24" Deep	
WSUD0634.5	

Trash Can Pull-Outs

- Designed to fit standard 24" deep Cabinet Systems cabinets.
- Natural Birch box and 3/4" thick Hard Maple edgebanded plywood top.
- Unit height is 6" to accommodate door mounting. Depth is fixed at 21-3/4".
- Blum TANDEM plus full extension drawer slides standard – no options.

TCPTS/CSTCPTS - Trash Can Pull-Out TANDEM Single

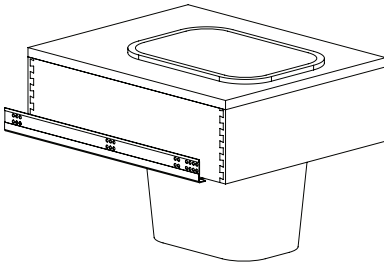

Custom Size Ranges
 Width: 18" – 21"
 Height: Min. opening 16"
 Depth: 24"

- Includes one 28-quart, grey color waste can.

Cabinet Code	
TCPTS1824	
TCPTS2124	

TCPTD/CSTCPTD - Trash Can Pull-Out TANDEM Double

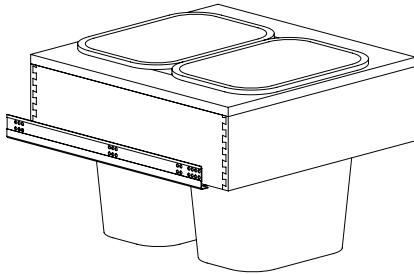

Custom Size Ranges
 Width: 24" – 30"
 Height: Min. opening 16"
 Depth: 24"

- Includes two 28-quart, grey color waste cans.

Cabinet Code	
TCPTD2424	TCPTD3024
TCPTD2724	

TCPTN/CSTCPTN - Trash Can Pull-Out TANDEM No Cut-Out

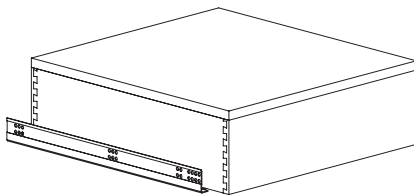

Custom Size Ranges
 Width: 18" – 30"
 Height: Min. opening 16"
 Depth: 24"

- Does not include waste can.
- Plywood top is shipped loose.

Cabinet Code	
TCPTN1824	TCPTN2724
TCPTN2124	TCPTN3024
TCPTN2424	

CSPOTB – Pull Out Tray Base

Custom Size Ranges
Width: 15" – 36"
Depth: 15", 18", 21",
24", 27", 30"

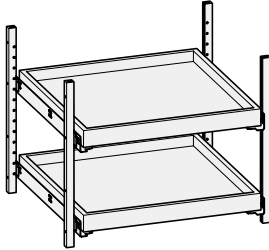

- CSPOTB includes 2 drawer boxes with a 2" height standard. Drawer box height is customizable.
- Each kit includes the following items:
 - ◆ 4 prefinished Hard Maple Pilasters.
 - ◆ 1 hardware pack and 1 set of TANDEM Drawer Slides per drawer box.
- Pilaster length is 19-5/8" and fits a standard Base cabinet. Pilasters can be trimmed or stacked to fit most cabinet configurations.
- Overlay must be selected when ordering to determine correct Pilaster width.
 - ◆ Overlay applications – 1-1/8" wide.
 - ◆ Inset applications – 2-3/8" wide.

CSPOTBFD – Pull Out Tray Base Full Door

Custom Size Ranges
Width: 15" – 36"
Depth: 15", 18", 21",
24", 27", 30"

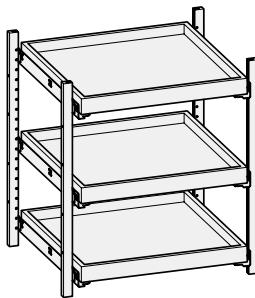

- CSPOTBFD includes 3 drawer boxes with a 2" height standard. Drawer box height is customizable.
- Each kit includes the following items:
 - ◆ 4 prefinished Hard Maple Pilasters.
 - ◆ 1 hardware pack and 1 set of TANDEM Drawer Slides per drawer box.
- Pilaster length is 27-3/16" and fits a standard Base full door cabinet. Pilasters can be trimmed or stacked to fit most cabinet configurations.
- Overlay must be selected when ordering to determine correct Pilaster width.
 - ◆ Overlay applications – 1-1/8" wide.
 - ◆ Inset applications – 2-3/8" wide.

CSPOTU – Pull Out Tray Utility

Custom Size Ranges
Width: 15" – 36"
Depth: 15", 18", 21",
24", 27", 30"

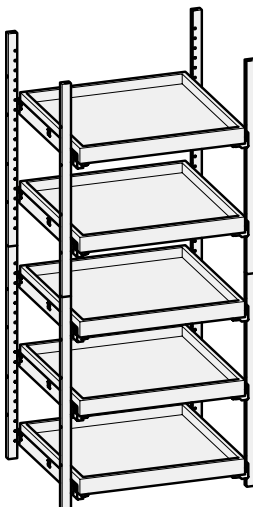

- CSPOTU includes 5 drawer boxes with a 2" height standard. Drawer box height is customizable.
- Each kit comes with the following items:
 - ◆ 8 prefinished Hard Maple Pilasters.
 - ◆ 1 hardware pack and 1 set of TANDEM Drawer Slides per drawer box.
- Pilaster length is 27-3/16" and is stacked to fit in a standard Utility cabinet. Pilasters can be trimmed or stacked to fit most cabinet configurations.
- Overlay must be selected when ordering to determine correct Pilaster width.
 - ◆ Overlay applications – 1-1/8" wide.
 - ◆ Inset applications – 2-3/8" wide.

Pull-Out Trays

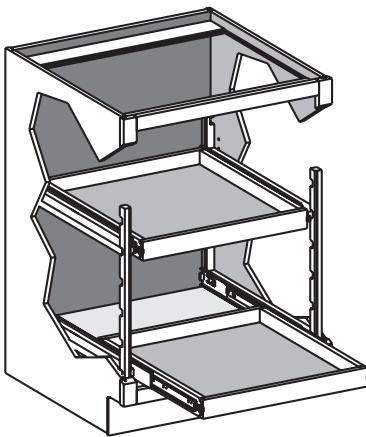

- Pull-Out Tray (POT) system includes corner cleats and dovetail trays.
- Provides tool-free location change of Pull-Out Trays.
- Adjustable pull-out system features unfinished Soft Maple installation components.
- Boxes are 2" high and available for 21" or 24" deep Base, Vanity or Tall cabinets.
- All POT kits available sized for inset (1-1/2" less in drawer box width) to allow for door clearance with non-mortise hinges. Also can be used in cabinets adjacent to a wall or a tall cabinet where doors may not open fully for additional clearance. Add "I" to the end of the POT code for inset sizing. Example: POT21524-I.
- POT system is sized for Blum TANDEM slides.

CSPOT1 - Pull-Out Trays

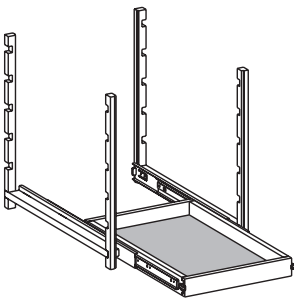

Custom Size Ranges
 Width: 15" – 36"
 Height: 34-1/2"
 Depth: 21", 24"

- Corner cleats can be trimmed to size when used with a shelf.
- For Base or Vanity cabinet with 1 Pull-Out Tray per opening.

CSPOT1CS - Pull-Out Trays

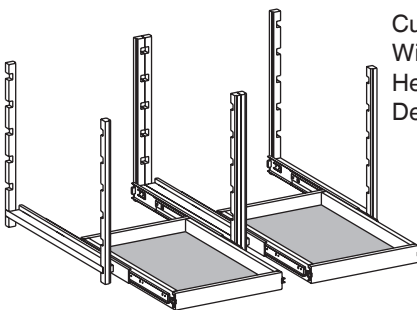

Custom Size Ranges
 Width: 30" – 48"
 Height: 34-1/2"
 Depth: 21", 24"

- Corner cleats can be trimmed to size when used with a shelf.
- For Base or Vanity cabinets with a center stile, 1 Pull-Out Tray per opening.

CSPOT2 - Pull-Out Trays

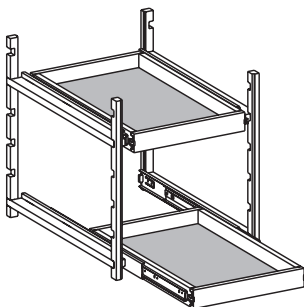

Custom Size Ranges
 Width: 15" – 36"
 Height: 34-1/2"
 Depth: 21", 24"

- Corner cleats can be trimmed to size when used with a shelf.
- For Base or Vanity cabinet with 2 Pull-Out Trays per opening.

CSPOT2CS - Pull-Out Trays

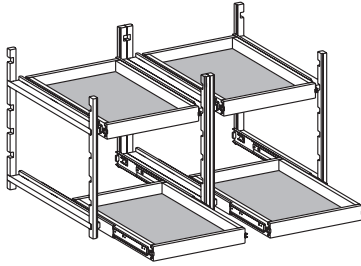

Custom Size Ranges
 Width: 30" – 48"
 Height: 34-1/2"
 Depth: 21", 24"

- Corner cleats can be trimmed to size when used with a shelf.
- For Base or Vanity cabinets with a center stile, 2 Pull-Out Trays per opening.

CSPOTT - Pull-Out Trays Tall

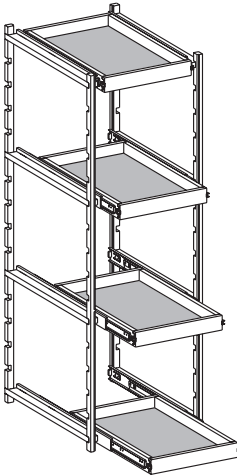

Custom Size Ranges
 Width: 15" – 36"
 Height: 84" – 96"
 Depth: 21", 24"

- Corner cleats can be trimmed to size when used with a shelf.
- Unit fits larger section of 84", 90", or 96" high cabinets.
- For Tall cabinets with 4 Pull-Out Trays per opening.

CSPOTS - Pull-Out Trays Single - Single Opening

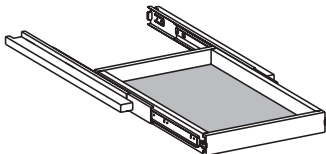

Custom Size Ranges
 Width: 15" – 48"
 Height: 34-1/2",
 84", 90", 96"
 Depth: 21", 24"

- No corner cleats included.
- Designed to be used when additional trays are needed within a POT system one opening wide.
- CSTPS includes: drawer cleats, slide, bumpers and one drawer box.

CSPOTSCS - Pull-Out Trays Single - Double Opening

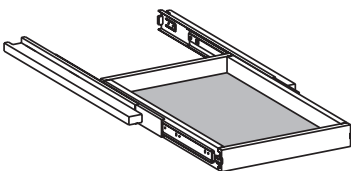

Custom Size Ranges
 Width: 30" – 48"
 Height: 34-1/2",
 84", 90", 96"
 Depth: 21", 24"

- No corner cleats included.
- Designed to be used when additional trays are needed within a POT system two openings wide.
- CSTPSCS includes: drawer cleats, slide, bumpers and one drawer box.

CSROS/CSROSI – Roll-Out Shelf

Custom Size Ranges
 Width: 15" – 36"
 Depth: 18", 21", 24",
 27", 30"

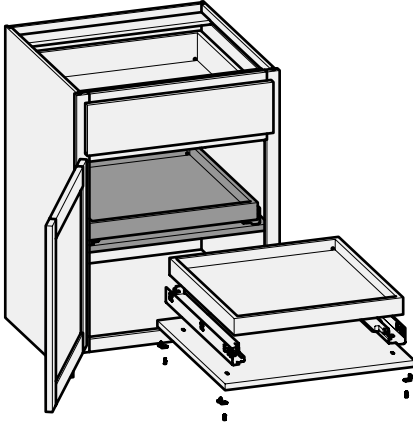

- Roll-Out Shelf (ROS) units can be added to most cabinets that have shelves 18" to 30" in depth.
- For inset applications use the CSROI. The CSROSI has a reduced drawer box width to allow proper clearance around inset hinges.
- Each ROS unit includes one pre-drilled shelf, 1 set of Blum TANDEM slides, shelf clips, and screws. All provided shelf clips and screws must be used when installing ROS to prevent the shelf from tipping when fully extended. Conestoga will not be responsible for ROS failure or injury due to improper or incomplete installation.
- Standard drawer box height is 2". Taller drawer boxes are available and must be specified.
- When ordering ROS enter cabinet width and depth to get the correct size ROS unit. Remember to omit shelving in the cabinet to avoid having extra shelves.
- No Shelf Option is available when adding a loose ROS unit to an existing shelf or fixed cabinet floor. When No Shelf Option is selected, pre-drilled shelf is omitted, and customer is required to drill holes for slides. Drill locations are provided on the ROS assembly instructions.
- ROS works with Prep False Door Option, but customer must drill mounting holes for drawer slide. Drill locations are provided on the ROS assembly instructions.
- 27" & 30" deep cabinets use a 24" deep Blum TANDEM slide. Drawer boxes will be manufactured at full depth with a spacer to accommodate the shorter slide length. When fully extended, drawer boxes in deeper cabinet depths will not extend beyond the front of the cabinet.
- In Con-Nex, ROS units can be ordered as an option on a cabinet and all cabinet modifications will update automatically.

11

Advantage Accessories

CSFFK – Loose Fixed Floor Kit

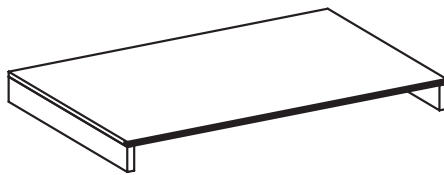

- Use Loose Fixed Floor Kits to horizontally segment most cabinets. Order cabinet without a front frame and order custom front frame as required.
- Loose Fixed Floor Kits are sized to fit between sides. Plywood cleats are included to mount floors as needed behind front frame openings. Floors include pre-inserted spines.
- Specify: CSFFK and the cabinet width and depth. Conestoga calculates the kit dimension based on the cabinet interior dimensions.
- Use Conestoga's online ordering system, Con-Nex or Conestoga order entry for pricing.

Standard Lazy Susan Shelves

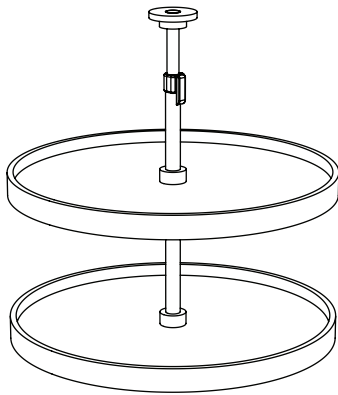

- White plastic susan with two independently rotating shelves mounted on a center pole.
- Shelves feature self lubricating nylon bearing and tool-free height adjustment.
- When standard lazy susan shelves are ordered, cabinet interior shelves are automatically omitted.
- See individual cabinet sections for standard lazy susan upgrade pricing.

Part No.	Sized for Cabinet	Description
2102946	WCS/CSWCSE (30" High) WCA/CSWCA (48" High) TTWCSE/CSTTWCSE (48" High)	18" Full Round
2102947	BCFD/CSBCFD	32" Full Round
2102948	BCP/CSBCP	32" Kidney
2102949	BCP30/CSBCP30	24" Kidney

Wood Lazy Susan Shelves

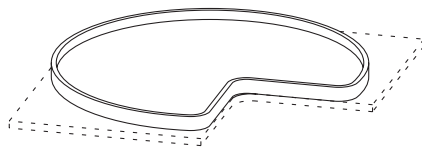

Kidney

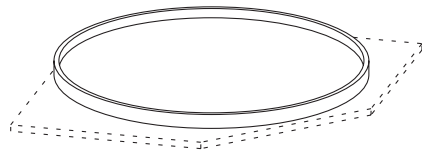

Full Round

- Wood susans are designed to be installed onto adjustable shelves and cabinet floors.
- Pricing includes susan and mounting ring bearing only, cabinet shelves not included.
- No center pole required.
- Sold individually and packaged with a center mounted ring bearing.
- All susans are prefinished with clear topcoat; unfinished units are not available.
- 1/2" thick Maple plywood with a 1-1/2" high laminated edge.

Part No.	Sized for Cabinet	Description
2100050A	BCP3634.5	32" Kidney-Wood Lazy Susan
2100051A	BCFD3634.5	32" Full Round-Wood Lazy Susan
2100053A	WCA/WCS	18" Full Round-Wood Lazy Susan

Finished Bottom Panels for Wall Cabinets

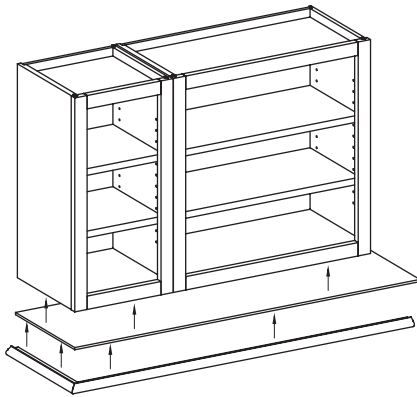

- 1/4" plywood strips in Cherry, Hard Maple and Red Oak are available in common wall depths x 96" long.
- Diagonal corner wall panels are available for WCS, WCSLS and TTWCSE cabinets.
- When attached to the underside of Wall cabinets, these panels provide flush finished bottoms.
- Use B-11 Light-Rail to cover exposed plywood edges.
- For best results attaching B-11 Light-Rail at end of run applications, order flush ends.

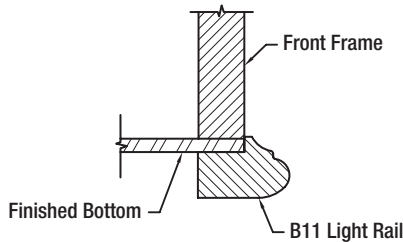

Panel Size/Design	Template No.
96" x 12-1/2"	TB5009
96" x 15-1/2"	
96" x 18"	
96" x 21"	
96" x 24"	
Corner panel 24" x 24"	TB5010
Corner panel 27" x 27"	

CSLTP – Loose Toe Platform / Prep Loose Toe Platform

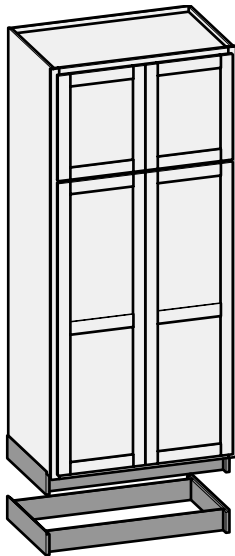

Custom Size Ranges
 Width: 12" – 36"
 Depth: 5-1/2" – 30"

- Loose Toe Platform is made with 3/4" plywood toe board returns running the depth of the cabinet and 1/2" plywood toe braces that run the width of the cabinet.
- Toe board returns are available in Hard Maple, Paint Grade Hard Maple, Cherry, or Red Oak when flush or exposed ends are selected.
- The Advantage Loose Toe Platform is available with most Utility cabinets. When ordering as a cabinet option, specify Loose Toe Platform or Prep for Loose Toe Platform. Enter the desired cabinet width, height and depth. The system will automatically subtract 4" from the cabinet height and remove the toe kick to account for the Loose Toe Platform.
- Prep for Loose Toe Platform Option reduces the cabinet height by 4" and removes the toe kick. Loose Toe Platform must be ordered separately.
- When ordering a custom size Loose Toe Platform independent of a cabinet, specify cabinet width and depth. Loose Toe Platform depth will be adjusted 3-3/4" to account for toe kick depth. Flush Toe Option is not available using the Advantage Toe Platform. Advantage Loose Toe Platform is not intended to support a run of cabinets.
- Prep for Loose Toe Platform is available on most cabinets that have a toe kick.

1/4" End Skins – Standard and Non-Standard Specie Option

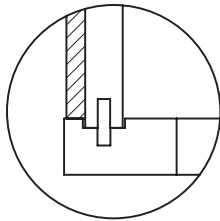
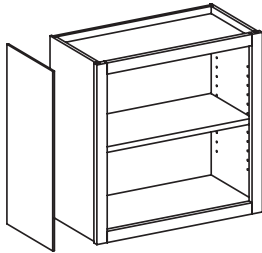

- Use End Skins when exposed or flush ends are necessary.
- **Standard Specie:** End Skins are 1/4" thick veneer core with sound backs. Face species are Plain Sliced B grade veneers.
- **Non-Standard Specie:** End Skins are 1/4" thick plywood with MDF core with matching specie face and back. Most species are Plain Sliced A faces with 1" backs except Red and White Birch which are rotary cut face and back.
- Species other than the standard program (Cherry, Hard Maple, Red Oak and Soft Maple) are available using custom specie front frames, and pre-cut matching specie End Skins for cabinet sides.
- End Skins are available finished or unfinished and will be sent separately from the cabinets. See Solid Wood Finishing Section 8 in the Custom Product Manual for finish pricing.
- When installed, 1/4" End Skins provide a nearly flush end and needs to be installed using an adhesive.
- Matching Specie Interior components are not available for non-standard species.
- To calculate End Skins for most cabinets: width = cabinet depth minus 3/4" length = overall cabinet height
- Conestoga's online software Con-Nex, will calculate pre-cut End Skins for visible cabinet ends based on the cabinet size. Specify Left, Right or Both sides that require End Skins.

Standard Species	Non-Standard Species	
Cherry	Alder	MDF* (Raw)
Maple, Hard	Bamboo (Caramelized)	Oak, White
Oak, Red	Birch, Red	Oak, White, Quarter Sawn
	Birch, White	Oak, White, Rift Cut
	Hickory	Walnut

*MDF End Skins are for painted applications. Front Frames are not available in MDF and a specie and grade must be specified. Paint Grade Hard Maple (PGHM) is recommended.

Exposed Ends (EXP)

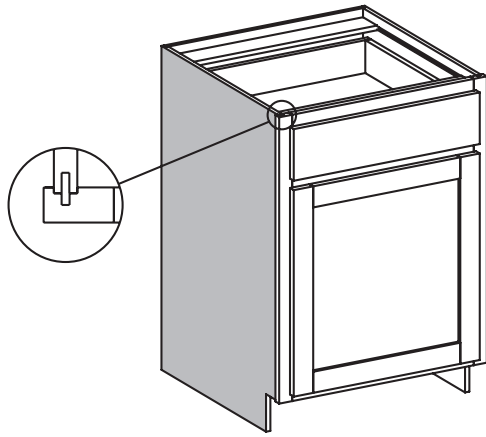

- Matching specie veneer on 1/2" thick cabinet sides.
- Specify: "L" (Left), "R" (Right) or "B" (Both).
- 1/4" reveal from edge of front frame to surface of the side.
- Hard Maple and Soft Maple cabinets have Hard Maple exposed ends.
- Use Conestoga's online ordering system, Con-Nex or Conestoga order entry for pricing.

Flush Ends (FL)

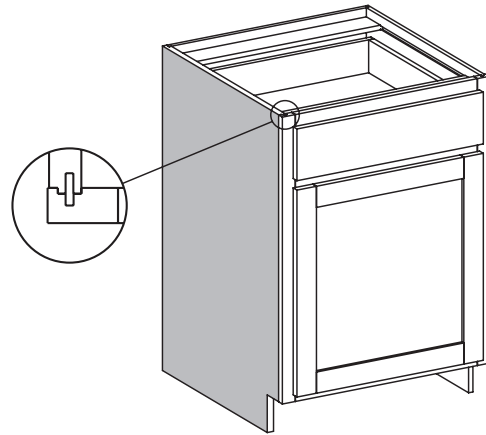

- Matching specie veneer on exposed of 3/4" thick cabinet sides.
- Specify: "L" (Left), "R" (Right) or "B" (Both).
- 1/32" reveal from edge of front frame to surface of the side.
- Hard Maple and Soft Maple cabinets have Hard Maple flush ends.
- All cabinets ordered with Colourtone, primer or Prism Paints will use a hybrid side panel.
 - ♦ Hybrid plywood side panels with Flush Ends have a paintable paper-coated MDF exterior and UV topcoated White Birch interior.
 - ♦ Hybrid plywood side panels on cabinets with both Flush Ends and Matching Interior will have a paintable MDF surface on both sides.
- Use Conestoga's online ordering system, Con-Nex or Conestoga order entry for pricing.

Flush Unexposed Ends (FUE)

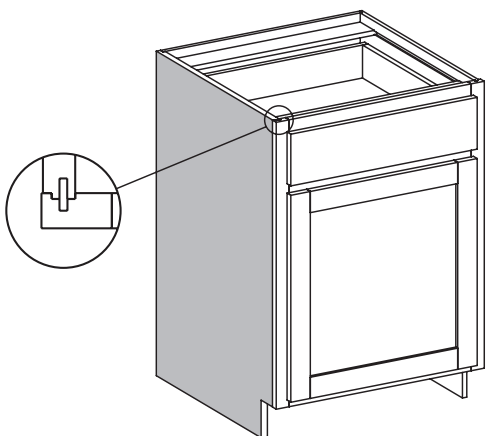

- Shop-grade veneer on exterior face of 3/4" thick cabinet sides – finishing is not available.
- Order when thicker, non-exposed sides are required for solid surface and stone countertops.
- Matching interior not available.
- Specify: "L" (Left), "R" (Right) or "B" (Both).
- 1/32" reveal from edge of front frame to surface of the side.
- Use Conestoga's online ordering system, Con-Nex or Conestoga order entry for pricing.

Prep for False Door Side Option (PFD)

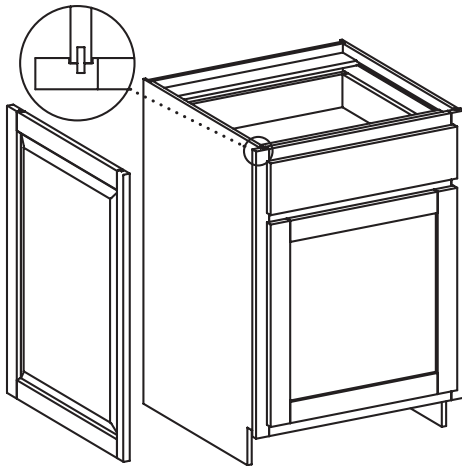

- Prepares the sides of Wall, Base, Tall or Vanity cabinets to accept 3/4" thick doors as decorative, integral cabinet sides.
- False doors not included, must be ordered separately.
- Cabinet carcass width is reduced to provide a 13/16" extension of the front frame on left, right or both sides. Overall cabinet front width remains unchanged.
- Left and right stiles are 1-1/2" wide.
- Specify: "L" (Left), "R" (Right) or "B" (Both).
- Available on most Wall, Base and Tall cabinets.
- Concealed Inset Hinges and Pull-Out Trays (POT's) are not available with Prepare for False Door Side Option.
- Order false door width 3/4" less than overall cabinet depth. Height of false door equals cabinet height.
- Use Conestoga's online ordering system, Con-Nex or Conestoga order entry for pricing.

False Door Side (FDS)

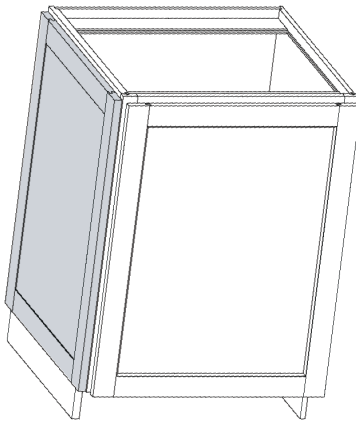

- Option calculates false door for decorative side appliques based on the overlay selected.
- Available in 1-1/4" and 1-3/8" overlays only.
- Minimum cabinet depth is 12".
- Option includes Flush End.
- Available with Custom Top Reveal (CTR) and Custom Bottom Reveal (CBR) Options. Calculation rules apply.
- Specify FDS "L" (Left), "R" (Right) or "B" (Both).
- Available on most Wall, Base and Tall cabinets.
- Option pricing is available when quoting/ordering through Con-Nex only.

Extend Side Back (ESB)

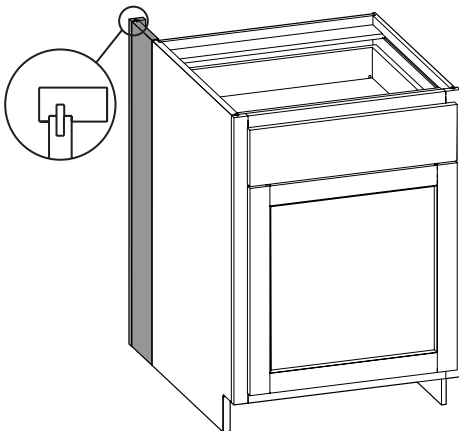

- Option extends cabinet side(s) to create island back seating space on most Base cabinets.
- Extension is customizable in 1/16" increments between 1" to 15" in depth.
- Maximum extension depth is 15".
- Extension edge can be ordered with end treatment options. Specify 1-1/2" to 3" width. The extension edge will receive a spline groove and a 3/4" thick stile will be grooved for standard Cabinet Systems spline assembly.
- Order 1/4" cut-to-size plywood to finish the inside of the extension and or the back of the island configuration.
- Use Conestoga's online ordering system, Con-Nex or Conestoga order entry for pricing.

Extended Height Option - Tall Cabinets

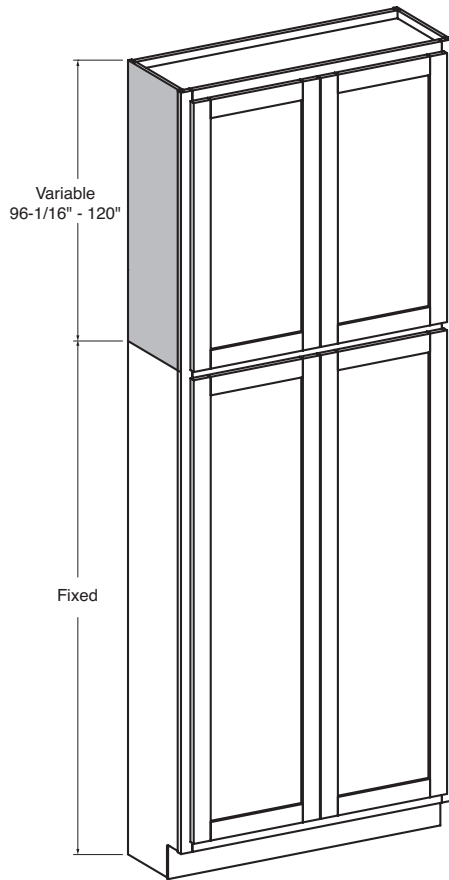

- Extended Height Option - Tall Cabinets
- Choose to extend height of Custom Size Tall Cabinets from 96-1/16" to 120".
- Available in Cherry and Hard Maple only.
- Flush ends only.
- Matching interiors not available. White Birch UV topcoated material will be used.
- Fixed section is based on cabinet configuration chosen.
- Separate 4" high toe platform is available in all heights and is strongly recommended for the extended height option.
- When cabinet height changes, top opening height changes accordingly.
- Maximum overall height is 120".
- 96-1/16" to 108" tall cabinet has eight shelves.
- 108-1/16" to 120" tall cabinet has nine shelves.
- Use Conestoga's online ordering system, Con-Nex or Conestoga order entry for pricing.

Toe Space Side Option (TSS)

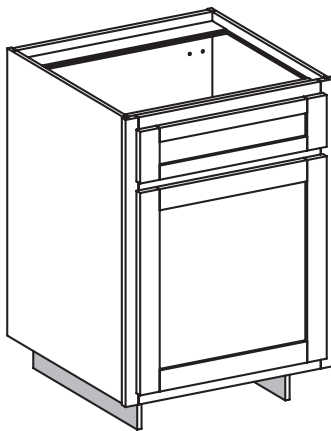

- Places standard toe space depth on the left, right or both sides of most base cabinets.
- Specify "TSS" – "L" (Left), "R" (Right) or "B" (Both).
- Toe Space Side Option is not available on the following cabinets: BCP, BCPLS, BSC, BCFD, BAE, BEAL/R, RTB, RTR, RTL, TCH, DB, DBFD, DB2D, DB3D, LF2D, ORS, DWEP, REP, BFC, WSUD and FS.
- Minimum cabinet width and depth is 15". TSS on both sides requires minimum depth of 18".
- Use Conestoga's online ordering system, Con-Nex or Conestoga order entry for pricing.

Plywood Toeboard Strips

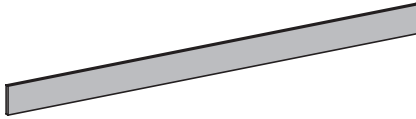

Plywood Toeboard Strips TE5003 (96" x 4")	
Specie	
Cherry	
Maple	
Oak, Red	

- 1/2" thick 96" x 4" plywood strips available in Cherry, Hard Maple or Red Oak.
- Order as a loose part; specify specie.
- Moulding Cut-Down Option is available on plywood Toeboard Strips to combat the exorbitant fees freight carriers are charging for packages 96" or longer.
- Option cuts down toestrip to 90".
- To order specify "Cut-Down to 90 Inch" Option.
- Upcharge applies; use Conestoga's online ordering system, Con-Nex or Conestoga order entry for pricing.

Plywood Toeboard Backer (PTB)

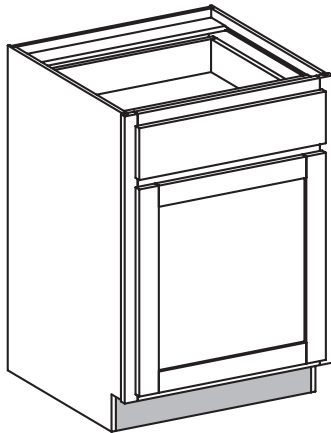

- 1/2" thick unfinished plywood strips.
- Designed to fully enclose Base, Tall and Vanity toe spaces and provide a backer for finished toeboards or mouldings.
- Backers are 4-15/16" high, sized to fit between cabinet sides in the toe space notch.
- To order, select Toeboard Backer Option.
- Use Conestoga's online ordering system, Con-Nex or Conestoga order entry for pricing.

Square Toe Kick Notch Option (STN)

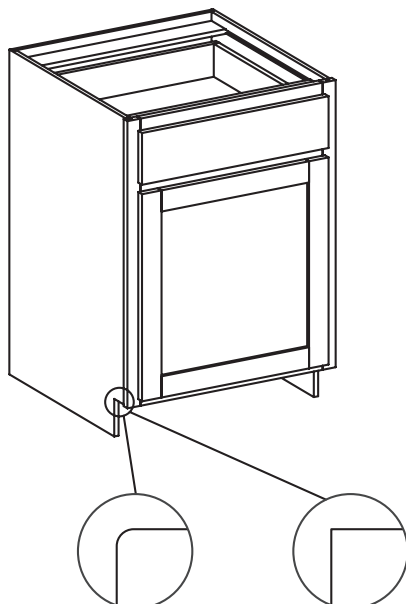

- Intersecting corner of Square Toe Kick Notch is 90°.
- Aids in Toeboard moulding installation.
- Available on most Base, Tall and Vanity cabinets.
- Not available with Flush Toe or Shaped Bottom Rail Options.
- Use Conestoga's online ordering system, Con-Nex or Conestoga order entry for pricing.

Extended Stiles (EXT)/Custom Extended Stiles (CSEXT)

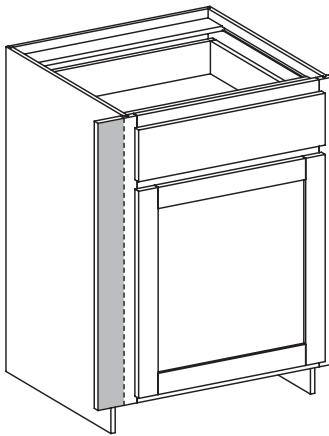

- Provides 3" wide frame extension (standard) for field trimming or custom width stile extensions to avoid cutting at installation.
- If CSEXT is ordered, stile width can be specified between 1/4" and 3" in 1/16" increments.
- For standard 3" extension specify: EXL (Extended Left), EXR (Extended Right) or EXB (Extended Both).
- For custom extension specify: CSEXL (Custom Extended Left), CSEXR (Custom Extended Right) or CSEXB (Custom Extended Both) followed by the width required.
- Available on most Wall, Base, Tall, Vanity and Home Office units.
- Use Conestoga's online ordering system, Con-Nex or Conestoga order entry for pricing.

Flush Toe (FT)

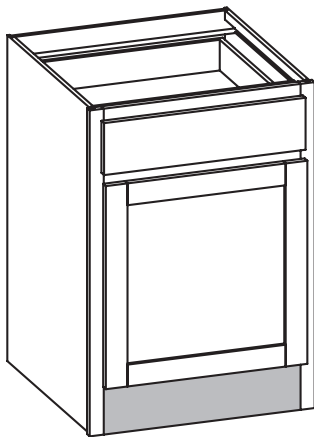

- Bottom rail height is 5-1/2".
- Specify: "FT" (Flush Toe).
- Cabinet side is manufactured without toe notch.
- 96" Tall cabinets do not use a toe platform.
- Available on most Base and Tall cabinets.
- Use Conestoga's online ordering system, Con-Nex or Conestoga order entry for pricing.

Leg Extension (LE)

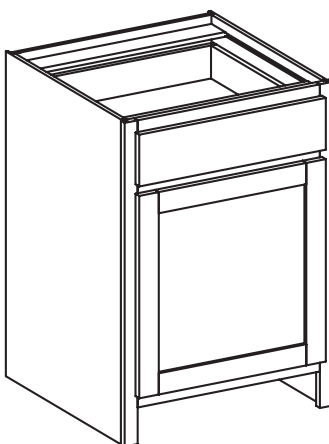

- Option extends exterior frame stiles to the floor into toe space for furniture "leg" styling.
- Specify "LE" - "L" (Left), "R" (Right) or "B" (Both).
- When "LE"- "B" is ordered with beaded inset, bottom opening will be beaded.
- Stile width is 1-1/2".
- Not available with loose toe platform or shaped bottom rail.
- Toe Space Side Option is available, not on the same side as the extension.
- Available on most Base, Tall and Vanity cabinets.
- Minimum cabinet width is 9".
- Toeboard Backer Option available. Install prior to final cabinet installation
- Use Conestoga's online ordering system, Con-Nex or Conestoga order entry for pricing.

Shaped Bottom Rail (SBR)/Shaped Side Option (SS)

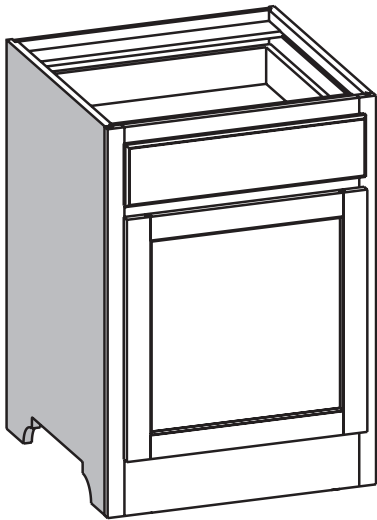
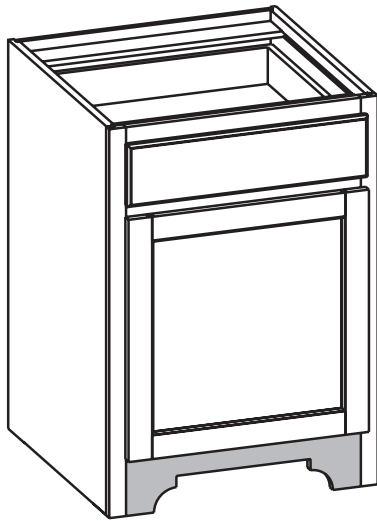

CWS6
Elegant Arch shown on both

- Rail height is 5-1/2". Flush toe is standard; cabinet side is constructed without toe notch.
- Roman, Elegant, Classic and Traditional Arch designs are centered on bottom rail and length of cabinet side.
- To order specify using CWS designations associated with the design – see shape options below.
- Not available with Loose Toe Platform (LTP) or Toe Space Side (TSS).
- Available on most Base, Tall and Vanity cabinets.
- Minimum cabinet width and depth is 15".
- **Shaped Side (SS)**
 - ◆ Specify “SS” – “L” (Left), “R” (Right) or “B” (Both).
 - ◆ Not available with Extended Stiles (EXT) or Flush Unexposed Ends (FUE).
- **Shaped Bottom Rail (SBR)**
 - ◆ Elegant 2 and Traditional 2 designs are available on the Left only, Right only or Both sides of the bottom rail.
 - ◆ Elegant 2 and Traditional 2 designs rise to 1-1/2" framing. These designs will not match Elegant or Traditional Arch designs.
 - ◆ Elegant 2 and Traditional 2 designs are not available with the Shaped Side Option.
- Use Conestoga’s online ordering system, Con-Nex or Conestoga order entry for pricing.

Shape Bottom Rail / Shaped Side



CWS4 – Roman Arch

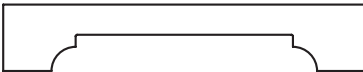

CWS6 – Elegant Arch



CWS5 – Classic Arch

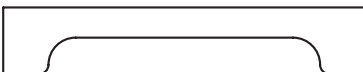

CWS7 – Traditional Arch

Shape Bottom Rail Only

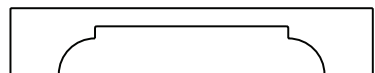

Elegant 2:
AB1B – Both
AB1L – Left
AB1R – Right

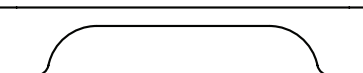

Traditional 2:
AB2B – Both
AB2L – Left
AB2R – Right

Shelf Options

Omit Shelving (OS)

- Choose to omit interior shelving in Wall, Base and Tall cabinets.
- Wall and Base Omit Shelving Option deletes all shelves.
- Tall cabinets: specify top, bottom or all shelves.
- Omits shelving only if shelf holes are not required, specify No Shelf Hole Option.
- Use Conestoga's online ordering system, Con-Nex or Conestoga order entry for pricing.

No Shelf Hole Option (NSH)

- Choose to omit line boring for shelf rests in Wall, Base and Tall cabinets.
- Most Wall and all Base No Shelf Hole Option deletes all holes.
- Two Tiered Wall (TTW) cabinets and Tall cabinets: specify Top, Bottom or All holes.
- Select No Shelf Holes Option only if shelves are not required, also specify Omit Shelving Option.
- No upcharge.

Extra Deep Shelf Option (EDS)

- Option increases shelf depth as cabinet depth is increased.
- Shelf depth is approximately 2" less than the overall cabinet depth.
- Plywood shelves only; not available with Solid Wood Shelf upgrade.
- Use Conestoga's online ordering system, Con-Nex or Conestoga order entry for pricing.

Solid Wood Shelf Upgrade (WS)

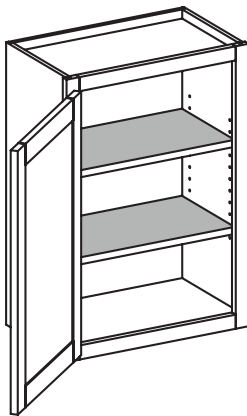

- Replaces 3/4" thick prefinished plywood shelving with 3/4" thick, prefinished solid wood shelving with a bullnose on front edge.
- Solid Wood Shelves available up to 18" deep.
- Solid Wood Shelf upgrade is not available with Matching Interior.
- Use Conestoga's online ordering system, Con-Nex or Conestoga order entry for pricing.

Matching Interior (MI)

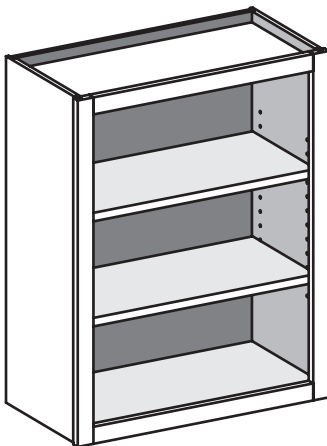

- Cabinets will have unfinished matching specie interior sides, tops, bottoms, shelves and backs.
- Specify: "MI" (Matching Interior).
- Flush unexposed ends are not available.
- Shelves are matching specie 3/4" plywood with veneer edgebanding on front edge.
- Matching specie available in Cherry, Hard Maple, Red Oak.
- Hard Maple and Soft Maple cabinets have Hard Maple veneered interior components.
- Cabinets with Matching Interior standard do not have the Matching Interior upcharge included in the cabinet price.

Dust Top (DT)

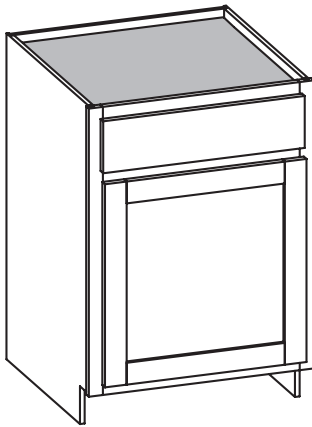

- Full top in place of front and back top strips.
- Use Conestoga's online ordering system, Con-Nex or Conestoga order entry for pricing.

Natural Finished Bottom (NB)

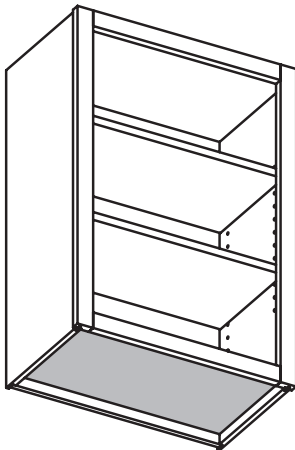

- Clear UV topcoated finish on White Birch veneer on top and bottom of Wall cabinets.
- To order, specify Natural finished bottom.
- Use Conestoga's online ordering system, Con-Nex or Conestoga order entry for pricing.

Custom Top Reveal (CTR)

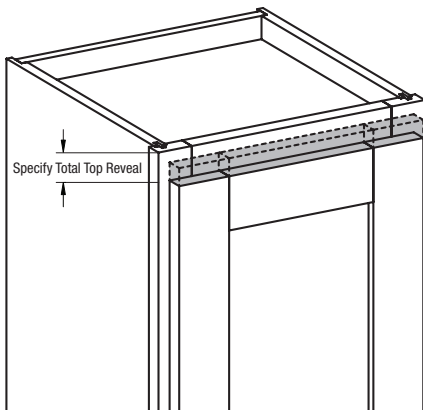

- Reduces door height to provide additional space to attach decorative mouldings directly to a cabinet front frame.
- Left, right and bottom reveal remain unchanged.
- Available with 1-1/4" and 1-3/8" overlay only. 1-1/4" overlay – 1/2" top reveal is standard, CTR available – 9/16" – 1-1/4". 1-3/8" overlay – 1/4" top reveal is standard, CTR available – 5/16" – 1-1/4".
- Reveal can be specified in 1/16" increments.
- Specify: "CTR" followed by the total amount of top reveal required.
- Maximum reveal is 1-1/4".
- See the Doors/Overlay Options Section for standard overlay rules.
- Use Conestoga's online ordering system, Con-Nex or Conestoga order entry for pricing.

Custom Bottom Reveal (CBR)

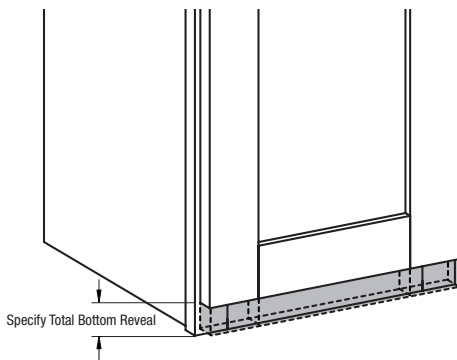

- Reduces door height to provide additional space to attach light rail or decorative mouldings directly to the bottom rail of the cabinet front frame.
- Left, right and top reveal remain unchanged.
- Available with 1-1/4" and 1-3/8" overlay only.
- Reveal can be specified in 1/16" increments.
- Specify: "CBR" followed by the total amount of bottom reveal required.
- Maximum reveal is 1-1/4".
- See the Doors/Overlay Options Section for standard overlay rules.
- Use Conestoga's online ordering system, Con-Nex or Conestoga order entry for pricing.

Increase Side Reveal (ISR)

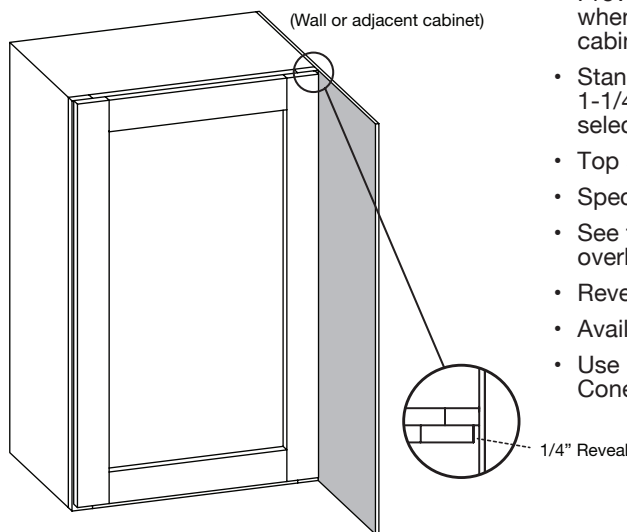

- Provides additional door clearance for 1-3/8" overlay when cabinets are installed adjacent to walls or deeper cabinetry.
- Standard reveal is changed from 1/8" to 1/4" and 1-1/4" overlay hinges will be provided when hinges are selected.
- Top and bottom reveal remain unchanged.
- Specify: "ISR" Left, Right or Both.
- See the Doors/Drawer Fronts Section for standard overlay rules.
- Reveal increased on the hinged side of doors.
- Available on most Wall, Base, Tall and Vanity cabinets.
- Use Conestoga's online ordering system, Con-Nex or Conestoga order entry for pricing.

Cabinet Hinge Options

BLUM Hinge Program Overview

- 1-piece steel, nickel-plated concealed hinges.
- Hinges packed in pairs or bulk pack and include mounting screws, installation instructions and warranty information.
- Hinge option is only available on door styles and edge profiles which support concealed hinge boring.
- Doors over 42" high will receive 3 hinges.
- Specify hinging Left or Right for single door cabinets if Hinge Boring Option is selected.
- Blum hinges carry a Limited-Lifetime Warranty.

COMPACT BLUMOTION – Hinges with Integrated Soft Close

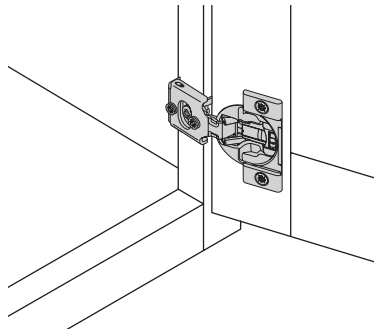

1/2" Overlay Hinge

Blum COMPACT BLUMOTION 38N
105° opening angle.

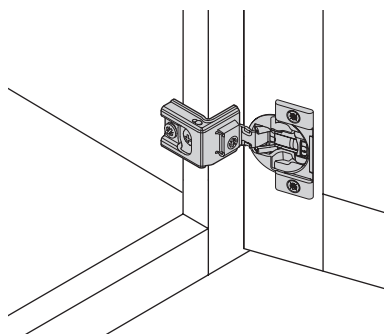

1-1/4" and 1-3/8" Overlay Hinge

Blum COMPACT BLUMOTION 39C
110° opening angle.

- Available for 1/2", 1-1/4" and 1-3/8" overlays.
- Available on 3/4" and 25/32" thick doors.
- Soft close feature is integrated within the hinge cup itself.
- Soft close function can be easily deactivated with a switch on individual hinges as needed based on the door size and weight.
- All hinges feature side, height, and depth adjustment for fine-tuning door spacing with wraparound front frame mounting for ease of installation.
- Blum COMPACT BLUMOTION hinges require Pattern "A" cup only boring.
- **Note:** When 1-1/4" or 1-3/8" overlay is ordered, Extended Stiles or Loose Filler Strips may be required in applications where cabinets are installed next to a tall cabinet, corner cabinet or a wall.
- Hinges available packaged in pairs or bulk pack (50 hinges per pack), including mounting screws.

COMPACT BLUMOTION Hinges (per pair)	
Part #	Overlay
2100150A	1/2"
2100151A	1-1/4"
2100152A	1-3/8"

COMPACT BLUMOTION Bulk Pack Hinges (50 hinges)	
Part #	Overlay
2100153A	1/2"
2100154A	1-1/4"
2100155A	1-3/8"

Cabinet Hinge Options (continued)

Blum Specialty Hinges

170° Hinges

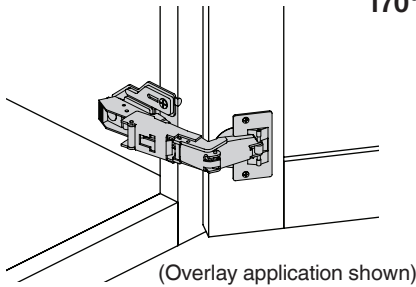

Overlay Application:

Blum 71T6550 hinge
Blum 175H6000 mounting plate

Inset Application:

Blum 71T6650 hinge
Blum 175H5030 mounting plate

- Provides full access to cabinet interiors with 170° opening angle for overlay and inset door applications.
- In 1-1/4" and 1-3/8" overlay applications, cabinets will have their doors sized as 1/2" overlay in width only.
- Available on 3/4" and 25/32" thick doors.
- 2-piece, clip style hinge with side, height and depth adjustment points.
- 170° corner hinges require Pattern "B" cup only boring.
- BLUMOTION soft close feature is not available.
- Standard on WCP and BCP cabinets.
- To order loose, specify:
 - Overlay application – part# 2100063A.
 - Inset application – part# 2100509A.
- Use Conestoga's online ordering system, Con-Nex or Conestoga order entry for pricing.

Inset Hardware

Inset Mounting Brackets for TANDEM plus BLUMOTION Drawer Slides

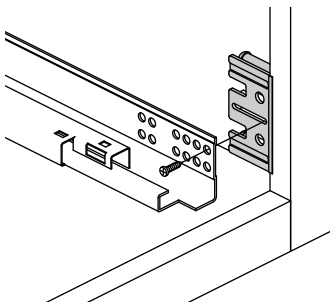

- Drawer slide adjustable mounting plate system for inset applications with framed cabinetry.
- Eliminates the need for supplemental blocking behind front frames to secure TANDEM slides.
- Sold in pairs, bracket sets include installation screws and instructions.
- Brackets afford up to 5/8" depth adjustment using standard TANDEM rear mounting brackets.
- To order loose, specify part# 2100200 (pairs).
- Use Conestoga's online ordering system, Con-Nex or Conestoga order entry for pricing.

Concealed Inset Hinges

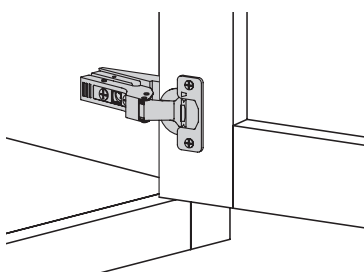
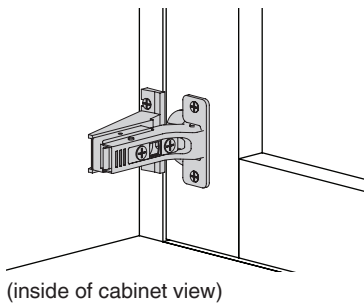

120° opening angle

Blum 71B3650NI hinge
Blum 175H5030.21 mounting plate

- Hinge and mounting plate system for concealed inset applications with framed cabinetry.
- Available on 3/4" and 25/32" thick doors.
- Soft close feature is integrated in the hinge cup.
- Hinge packs include screws and two adjustable door stops with bumpers.
- Concealed inset hinges require Pattern "B" cup only boring.
- Door and front frame thickness must match.
- To order loose, specify part# 2100067A (pairs).
- Use Conestoga's online ordering system, Con-Nex or Conestoga order entry for pricing.

Cabinet Hinge Options (continued)

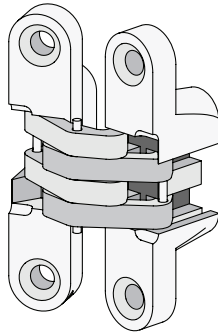

SOSS Hinge

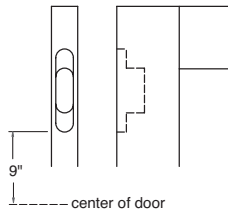

SOSS Hinge Option

- SOSS Hinge Model 204 Invisible Hinge provides 180 degree bi-fold hinge for corner pie cut cabinets.
- Available with WCP/CSWCP, WCPLS/CSWCLPLS, BCP/CSBCP and BCPLS cabinets.
- Available in Brass or Chrome finish; specify finish when ordering.
- Includes SOSS hinge boring; Routs are placed 9" off center, measure from the vertical center of the door to the start of the rout.
- Not available on doors over 42" high or under 25-1/8" high.

Drawer Slide Options

Blum TANDEM Plus BLUMOTION Integrated Soft Close

- Standard slide for drawer boxes in 12", 15", 18", 21", 24", 27" and 30" deep cabinets.
- Full extension zinc-coated steel with rear mount screw-in bracket (15", 18", 21" or 24" deep).
- Cabinet backs have pilot holes to locate rear mounting brackets.
- Side mount with cleats (12", 27", or 30" deep).
- 1/2" bottom reveal, undermount notch and hook hole required. Blum TANDEM sizing without slides also available.
- Blum drawer slides carry a Limited-Lifetime Warranty.
- Use Conestoga's online ordering system, Con-Nex or Conestoga order entry for pricing.

Ordering - Loose Parts

Cabinet Depth	Blum TANDEM Plus BLUMOTION
12" Deep	2100497A
15" Deep	2100498A
18" Deep	2100476A
21" Deep	2100475A
24" Deep	2100474A

Cabinet Depth	Blum MOVENTO with Soft Close
27" Deep	2100499A
30" Deep	2100500A

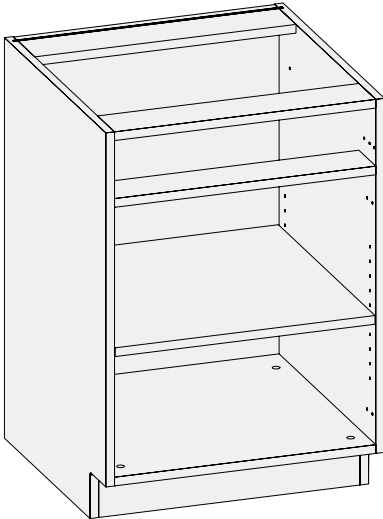
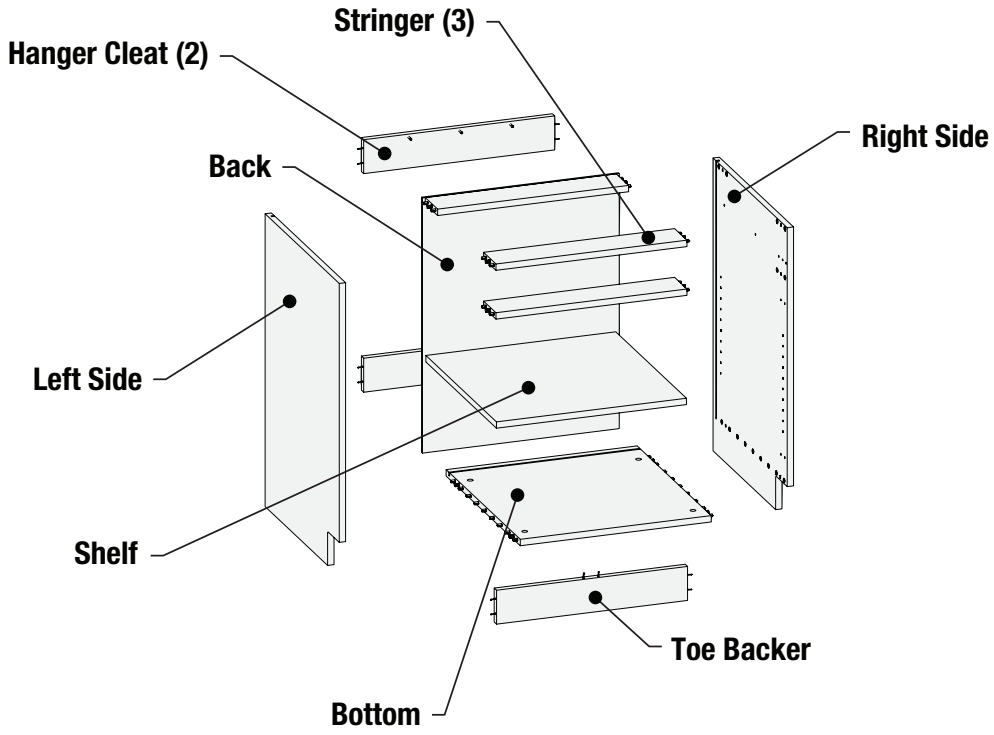

Vesta Design and Assembly

The Vesta Full Access cabinet line offers 2 construction materials, precut and machined for quick and easy assembly.

Plywood and Particleboard Cabinet Construction

Vesta offers both 3/4" thick particle board and plywood case materials for cabinet sides, tops, bottoms, and stringers. Cabinet backs are 1/4" thick.

- **Particle Board Cabinet Case Materials:** 3/4" thickness tops, bottoms, sides and shelves; and 1/4" thick back utilize particle board core case material with melamine finish on both sides in either Coastal White or Fog Grey, unless Matching Case Color is selected. When Matching Case Color is selected in Vogue or Strata the back thickness is 8mm; Intrigue Matching Cases utilize a 1/4" thick back. Wood edgeband with a matching finish is valid on Coastal White or Fog Grey cabinet cases.
- **Plywood Cabinet Case Materials:** The 3/4" plywood case material has White Birch UV topcoat on both sides unless Matching Case Color is selected. The 1/4" backs are White Birch plywood with a UV topcoat on both sides. The core of the back material is MDF for dimensional stability and flatness. Door matching Allure, Intrigue, Strata, Vogue, Synchronicity High Gloss and Synchronicity Super Matte edgeband is also available on a plywood cabinet cases.

Edgeband: Edgeband color must be selected from either case matching PVC edgeband (Coastal White, Fog Grey or White Birch) or Door Matching Edgeband. Door Matching Edgeband is wood veneer for wood doors and PVC for Alternate Material doors. Wood edgeband is finished to match the finish on the door. Painted finishes automatically utilize a paintable PVC edgeband.

- Tops, bottoms, sides and stringers of Base and Utility cabinets are edgebanded on the front edge with selected edgeband.
- Wall cabinet sides are edgebanded on the top, bottom and front edge. The front edge will be banded with the selected edgeband, while the edgeband on the top and bottom of the Wall side panel will match the case color unless plywood Exposed Ends are selected. When plywood Exposed Ends are selected all 3 edges will match the selected door edgeband color.
- Shelves are edgebanded on the front edge only. The shelf and edgeband will always match the interior case color.
- Visible structural parts such as uprights on blind cabinets or stringers on sink cabinets will always match the selected edgeband color.

Hardware Machining: All cabinet sides are predrilled for Blum INSERTA hinges and Blum TANDEM drawer slides as needed for fast and easy installation.

Stringers: Most Base cabinets have open tops with two 3/4" thick by 4" deep stringers running across the full width of the cabinet in the front and back. Base Sink cabinets with drawers have an additional stringer below the top drawer opening. Sink and Vanity Sink cabinets have two 3/4" thick by 6-1/2" wide stringers that run the width of the cabinet, providing a fully accessible opening for sink installation. Some Specialty Base cabinets have full tops.

Backs: 1/4" thick back is fully captured in a dado between tops, bottoms, and sides for Wall and Utility cabinets. In Base cabinets, the back is captured between bottom and sides, while the top of the back is flush with the stringers of the assembled cabinet. Note: If Vogue or Strata are selected, backs will be 8mm thick.

Shelves and Shelf Holes: On cabinets with shelves the shelf height is adjustable in 32mm increments. Shelf holes and shelves can be omitted from any cabinet by selecting No Shelf Holes (NSH) and Omit Shelf (OS) Options. Shelves and shelf holes can be removed by individual opening on multi-opening cabinets such as Utility cabinets.

Drawer Boxes: English dovetail construction with 5/8" thick solid wood sides with eased top edges. 1/4" thick plywood bottoms standard; 3/8" thick plywood bottoms and additional drawer box options available. Drawer boxes are finished with a durable UV topcoat. Natural Birch standard, Hard Maple and Walnut upgrades available.

Vesta Design and Assembly (continued)

Toeboard Backers: 3/4" thick plywood, designed to fully enclose toe space and provide support for applied, finished toeboards. Toeboard backers are plywood regardless of the case material selected.

Toeboard Strips: Particle board strips are 3/4" thick x 4" high x 8' long in all plywood, Intrigue, Strata, and Vogue colors. 1/2" plywood strips available in Cherry, Hard Maple or Red Oak. 3/4" plywood strips available in Cherry, Hard Maple, Paint Grade, Red Oak, Rift Cut White Oak and Walnut.

Hanger Cleats: 3/4" thick plywood hanger cleats are attached using pocket screws in pre-drilled holes. This construction draws the back against the dado to minimize gaps, as well as provide a secure surface area for installation screws. Backs are inset 1/4" from the back edge of cabinet sides to account for irregularities in wall surfaces. Hanger cleats are plywood regardless of the case material selected.

Interior Finish: Coastal White or Fog Grey melamine interiors, or White Birch with UV topcoat interior is standard on backs, tops, bottoms, stringers and sides. Matching Case Color Option (MCC) is available in all plywood, Intrigue, Strata, and Vogue colors. Finishing is only available on plywood when Matching Case Color (MCC) is selected. See tables on following page for materials and availability.

Vesta Material Availability

Material	Vesta Alternative Material Availability						
	Doors/Drawer Fronts	Door Matching Edgeband	Matching Case Color	Exposed Ends	Door End Panel	Mouldings/Fillers	3/4" Cut-to-Size Panels
Allure	Yes	Yes	No	No	Yes	Yes	No
Intrigue	Yes	Yes	Yes	No	Yes	Yes	Yes
Synchronicity High Gloss	Yes	Yes	No	No	Yes	Yes	Yes
Synchronicity Super Matte	Yes	Yes	No	No	Yes	Yes	Yes
Strata	Yes	Yes	Yes	No	Yes	Yes	Yes
Vogue	Yes	Yes	Yes	No	Yes	Yes	Yes

Specie	Vesta Component Specie Availability							
	Cabinet Case Species	Doors/Drawer Fronts	Door Matching Edgeband	Exposed Ends	Door End Panel	Mouldings	3/4" Cut-to-Size Plywood	Wood Edgeband
Alder	No	Yes	No	No	Yes	Yes	No	Yes
Bamboo	No	Yes	Yes	No	Yes	Yes	Yes	Yes
Birch, Red	No	Yes	No	No	Yes	Yes	No	No
Birch, White	No	Yes*	No	No	Yes*	Yes	No	Yes
Cherry	Yes	Yes*	Yes	Yes	Yes*	Yes	Yes	Yes
Hickory	No	Yes*	No	No	Yes*	Yes	No	Yes
Mahogany	No	Yes	No	No	Yes	Yes	No	No
Maple, Hard	Yes	Yes*	Yes	Yes	Yes*	Yes	Yes	Yes
Maple, Soft	Yes	Yes	Yes**	Yes**	Yes	Yes	Yes**	Yes**
Oak, Red	Yes	Yes*	Yes	Yes	Yes*	Yes	Yes	Yes
Oak, Red, Rift Cut	No	Yes	Yes	No	Yes	No	Yes	Yes†
Oak, White	No	Yes*	No	No	Yes*	Yes	No	Yes
Oak, White, Rift Cut	Yes	Yes	Yes	No	Yes	No	Yes	Yes†
Oak, White, Quarter Sawn	No	Yes	No	No	Yes	No	No	No
Paint Grade	Yes	Yes	Yes	Yes	Yes	Yes	No	No
Paint Grade Hard Maple	No	Yes	Yes	Yes	Yes	Yes	No	No
Pine, Clear	No	Yes*	No	No	Yes*	Yes	No	No
Pine, Knotty	No	Yes	No	No	Yes	Yes	No	No
MDF	No	Yes	No	No	Yes	No	Yes	No
Walnut	Yes	Yes*	Yes	No	Yes*	Yes	Yes	Yes

Standard plywood case has a White Birch interior with UV topcoat and an unfinished Natural Birch exterior. For specie modification, select from Matching Case Color (MCC) or Exposed Ends (EXP).

*Specie is also available in Premium grade for doors and drawer fronts only. Material upcharge applies.

**When Soft Maple is ordered, plywood components are produced using Hard Maple plywood and edgeband. Solid wood components are produced using Soft Maple.

†When ordering Vesta Components in Rift Cut Red Oak or Rift Cut White Oak, wood edgeband is standard Oak, Not Rift Cut.

Vesta Construction Methods:

Conestoga offers two construction methods to accommodate customer preferences. The first Ready to Assemble cabinet construction method is Cam & Post construction. The second construction method is referred to as Screw & Dowel construction. The Screw & Dowel construction requires proper planning and the ability to clamp the cabinet together when exposed ends are utilized. Both construction methods require woodworking glue to be applied to all dowel holes and back dados.

Cam & Post Construction:

- The Cam & Post construction method requires a rubber mallet, #2 Pozidriv screwdriver, and a drill with a #2 square drive bit.
- Tops, bottoms, and stringers are pre-drilled and delivered with cams, posts, and dowels inserted.
- All side construction holes are pre-drilled to accept the pre-inserted dowels and posts on the top, bottom, and stringers.
- Cover caps are provided to conceal the cams.
- **Assembly Instructions are provided upon request, select on order form if needed or download from the Customer Business Portal.**

Screw & Dowel Construction:

- The Screw & Dowel construction method requires a rubber mallet, #2 Pozidriv screwdriver, a drill with a #2 square drive bit, and the ability to clamp as needed. A clamp can be a pipe/bar clamp or a case clamp.
- Tops, bottoms, and stringers are pre-drilled and delivered with dowels inserted.
- All side construction holes are pre-drilled to accept the pre-inserted dowels on tops, bottoms, and stringers. Pilot holes are drilled in the cabinet sides to center the self-tapping screws.
- Exposed Ends MUST be identified as Left, Right, Both, or None when ordering Screw & Dowel construction anytime the case color matches the door color. When Exposed Ends are selected the pilot holes will not be drilled in cabinet sides.
- Cabinets with Exposed Ends must be properly glued and clamped to ensure a proper glue joint. Self-tapping screws are provided to be used in areas of the cabinet side that may not be exposed. Pinning, pocket screws, or finish screws can be added at customer's discretion.
- **Assembly Instructions provided upon request, select on order form if needed, or download from the Customer Business Portal.**

Door Overlay Diagram

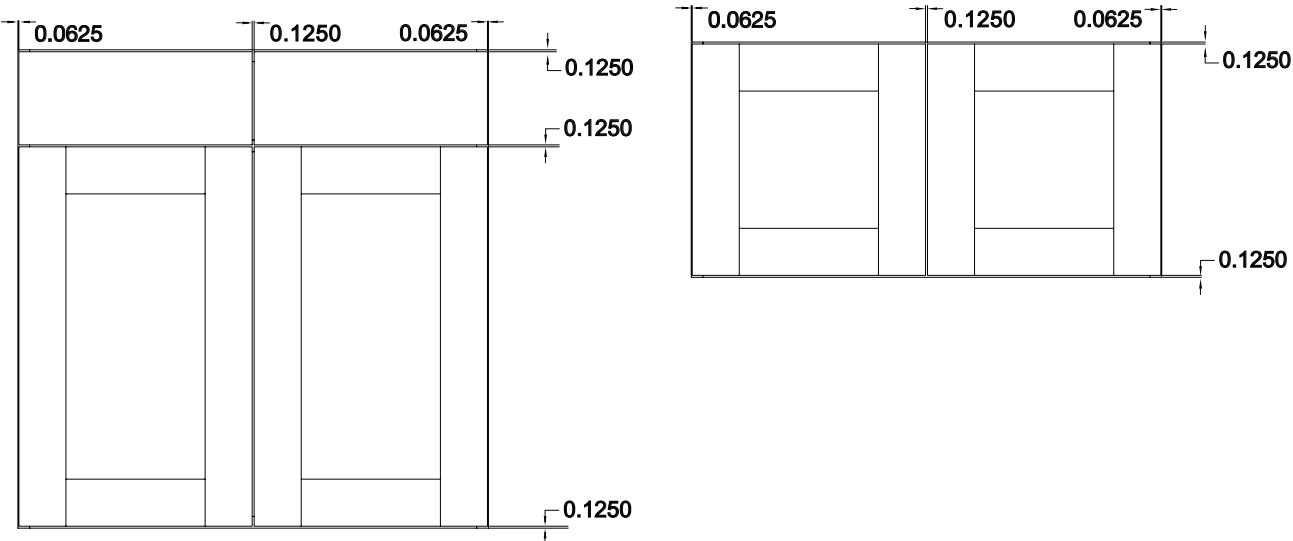

Vesta Wall Cabinet Standard Features and Options

The features below are standard on all Wall cabinets where the design permits. Many standard features can be omitted as needed. The option to omit standard features as well as add design options can be quickly referenced at the bottom of each page in Wall Cabinet Section labeled “Wall Options Key”. For a detailed description and image of the individual options, see Options, Section 20 of this manual. Standard features and options are available on all Wall cabinets unless specifically noted as **Unavailable Option**.

Edgeband – Our Wall cabinets sides, tops, bottoms, mid-floors, and shelves are edgebanded on the front edge only. Interior parts such as uprights or other support members are edgebanded on any visible edges. Edgeband color must be specified to either match the case color (standard offering) or door color if applicable (upcharge applies). When Door Matching Edgeband Option is selected the front edges of the cabinet sides, top, bottom and mid-floor are edgebanded using the door color. The edgeband on the shelves and interior parts will always match the interior case color. Door Matching Edgeband Option available with all Allure DLV, Intrigue TTS, Strata TTS, Vogue TTS, Synchronicity High Gloss and Super Matte colors, as well as wood edgeband in Cherry, Hard Maple, Paint Grade, Red Oak, Rift Cut White Oak and Walnut.

5mm Shelf Holes – 5mm Shelf Holes are pre-drilled on 32mm centers of all cabinets with shelves. **No Shelf Holes (NSH)** and **Omit Shelving (OS)** Options are available on any Wall cabinet with shelves. If both the No Shelf Holes and Omit Shelving Options are required, both must be individually specified.

Hinge Hole Drilling – All Wall cabinets eligible to receive doors will include Blum Frameless INSERTA Hinges and are pre-drilled with 5mm holes to accept the EXPANDO Mounting Plates. A **No Hinge Hole (NHH)** Option is available on any Wall cabinet that would typically include doors. Cabinet hinges can also be omitted, but must be changed from the default of Yes to No. The No Hinge Holes Option does not remove hinges; No Hinges must be specified.

Drawer Slide Hole Drilling – All Wall cabinets that include drawer boxes also include Blum TANDEM Drawer Slides and are pre-drilled with 5mm holes for quick and easy installation. The **No Drawer Slide Hole (NDSH)** Option is available only on cabinets with drawer boxes. Drawer slides can be omitted, but must be changed from the default of Yes to No. The No Shelf Holes Option does not automatically remove drawer slides; No Drawer Slides must be specified.

Matching Case Color (MCC) – With the Matching Case Color Option, the door and drawer front color matches the cabinet interior, exterior and edgeband. The Matching Case Color Option is available with most Wall cabinets and produced in all published Intrigue TTS, Strata TTS and Vogue TTS colors as well as wood edgeband in Cherry, Hard Maple, Paint Grade, Red Oak, Rift Cut White Oak and Walnut.

Wall Options Key: **MCC** = Matching Case Color **NHH** = No Hinge Holes **NSH** = No Shelf Holes **NDSH** = No Drawer Slide Holes **OS** = Omit Shelving
Design Notes:

Standard edgeband color matches cabinet interior color (Coastal White, Fog Grey or White Birch). Edgeband that matches doors/drawer fronts is available and must be specified. Upcharge applies. Use fillers when installing cabinets adjacent to walls and other cabinets to ensure adequate clearance for doors and drawers. Conestoga recommends that exposed ends be capped with 19mm thick applied decorative end panels (optional and must be specified). When this treatment is used, adjust cabinet width(s) accordingly.

W/CSW - Wall Cabinet

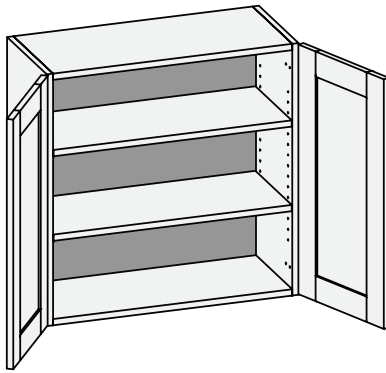

Custom Size Ranges
 Single Door Width: 9" – 24"
 Butt Door Width: 24" – 36"
 Height: 6" – 72"
 Depth: 8" – 30"

- 12" – 18" high has no shelves.
- 18-1/16" – 24" high has one shelf.
- 24-1/16" – 36" high has two shelves.
- 36-1/16" – 48" high has three shelves.
- 48-1/16" – 60" high has four shelves.
- 60-1/16" – 72" high has five shelves.
- Specify single or butt doors on custom size cabinets 24" wide.

Single Door Cabinets – 13" Deep		
30" High	36" High	42" High
W0930	W0936	W0942
W1230	W1236	W1242
W1530	W1536	W1542
W1830	W1836	W1842
W2130	W2136	W2142
W2430	W2436	W2442

Butt Door Cabinets – 13" Deep								
12" High	15" High	18" High	21" High	24" High	27" High	30" High	36" High	42" High
W3012BD	W2715BD	W2718BD	W2421BD	W2424BD	W3027BD	W2430BD	W2436BD	W2442BD
W3312BD	W3015BD	W3018BD	W2721BD	W2724BD	W3327BD	W2730BD	W2736BD	W2742BD
W3612BD	W3315BD	W3318BD	W3021BD	W3024BD	W3627BD	W3030BD	W3036BD	W3042BD
	W3615BD	W3618BD	W3321BD	W3324BD		W3330BD	W3336BD	W3342BD
			W3621BD	W3624BD		W3630BD	W3636BD	W3642BD

Butt Door Cabinets _ 24" Deep					
12" High	15" High	18" High	21" High	24" High	27" High
WD3012BD	WD3015BD	WD3018BD	WD3021BD	WD3024BD	WD3027BD
WD3312BD	WD3315BD	WD3318BD	WD3321BD	WD3324BD	WD3327BD
WD3612BD	WD3615BD	WD3618BD	WD3621BD	WD3624BD	WD3627BD

Wall Options Key: MCC = Matching Case Color NHH = No Hinge Holes NSH = No Shelf Holes NDSH = No Drawer Slide Holes OS = Omit Shelving
Design Notes:

Standard edgeband color matches cabinet interior color (Coastal White, Fog Grey or White Birch). Edgeband that matches doors/drawer fronts is available and must be specified. Upcharge applies. Use fillers when installing cabinets adjacent to walls and other cabinets to ensure adequate clearance for doors and drawers. Conestoga recommends that exposed ends be capped with 19mm thick applied decorative end panels (optional and must be specified). When this treatment is used, adjust cabinet width(s) accordingly.

WBC/CSWBC - Wall Blind Corner

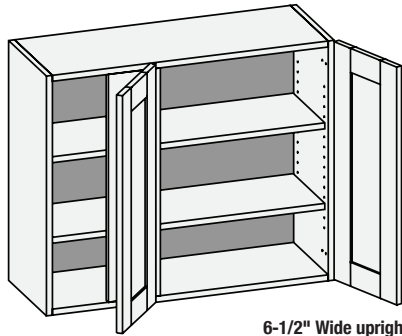

Custom Size Ranges
 Single Door Width: 27" – 48"
 Butt Door Width: 36" – 48"
 Height: 12" – 72"
 Depth: 8" – 27"
 Functional Opening: 12" – 38"

- Units are reversible (left shown).
- Specify functional opening width between 12" - 38".
- Minimum blind opening is 1".
- 12" – 18" high has no shelves.
- 18-1/16" – 24" high has one shelf.
- 24-1/16" – 36" high has two shelves.
- 36-1/16" – 48" high has three shelves.
- 48-1/16" – 60" high has four shelves.
- 60-1/16" – 72" high has five shelves.
- Specify single or butt doors functional opening width 24".

Single Door Cabinets – 13" Deep

21" High	30" High	36" High	42" High
WBC2721	WBC2730	WBC2736	WBC2742
WBC3621	WBC3030	WBC3036	WBC3042
	WBC3630	WBC3636	WBC3642

Butt Door Cabinets – 13" Deep

30" High	36" High	42" High
WBC4230BD	WBC4236BD	WBC4242BD
WBC4830BD	WBC4836BD	WBC4842BD

WCS/CSWCSE - Wall Corner Single Entry

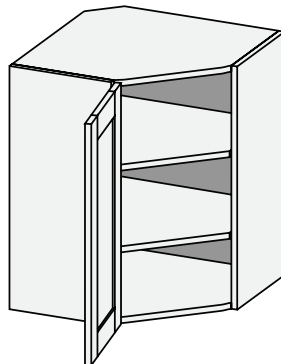

Custom Size Ranges
 Width: 24", 27"
 Height: 12" – 72"
 Depth: 24", 27"

- WCS24 units have 13" deep sides.
- WCS27 units have 16" deep sides.
- 24" – 36" high has two shelves.
- 36-1/16" – 48" high has three shelves.
- 48-1/16" – 60" high has four shelves.
- 60-1/16" – 72" high has five shelves.
- Shelf mounted wood susan shelves are available. See Section 19 – Accessories.

30" High	36" High	42" High
WCS2430	WCS2436	WCS2442
WCS2730	WCS2736	WCS2742

WCSLS - Wall Corner Single Entry with Lazy Susan

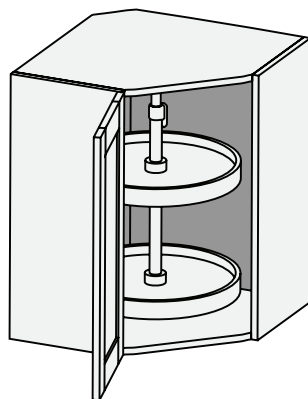

Custom Size Ranges
 Width: 24", 27"
 Height: 30"
 Depth: 24", 27"

- WCSLS24 has 13" deep sides.
- WCSLS27 has 16" deep sides. Cabinet top and bottom is pre-drilled to accept hub assembly.
- Cabinet includes 18" diameter entry level plastic susan with two independently rotating shelves mounted on a center pole.
- White susan shelves feature a self-lubricating nylon bearings and tool-free height adjustment.
- Size customization is not available due to susan size constraints.

30" High	
WCSLS2430	WCSLS2730

Wall Options Key: MCC = Matching Case Color NHH = No Hinge Holes NSH = No Shelf Holes NDSH = No Drawer Slide Holes OS = Omit Shelving
Design Notes:

Standard edgeband color matches cabinet interior color (Coastal White, Fog Grey or White Birch). Edgeband that matches doors/drawer fronts is available and must be specified. Upcharge applies. Use fillers when installing cabinets adjacent to walls and other cabinets to ensure adequate clearance for doors and drawers. Conestoga recommends that exposed ends be capped with 19mm thick applied decorative end panels (optional and must be specified). When this treatment is used, adjust cabinet width(s) accordingly.

WCP/CSWCP - Wall Corner Pie Cut

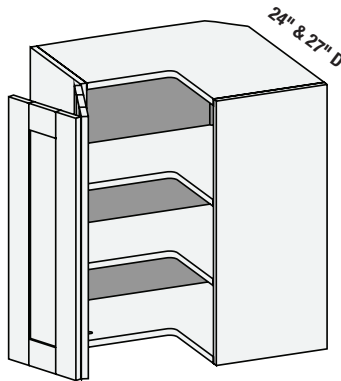

Custom Size Ranges

24" Wide:
 Width: 24" – 27"
 Height: 12" – 72"
 Depth: 24" – 27"

27" Wide:
 Width: 27" – 30"
 Height: 12" – 72"
 Depth: 27" – 30"

- WCP24 units have 13" deep sides.
- WCP27 units have 16" deep sides.
- 24" – 36" high has two shelves.
- 36-1/16" – 48" high has three shelves.
- 48-1/16" – 60" high has four shelves.
- 60-1/16" – 72" high has five shelves.
- CSWCP available with custom size legs. Specify width (left dimension) and depth (right dimension). Side depth remains fixed; pie cut opening adjusts as size changes.
- Shelf mounted wood susan shelves are available. See Section 19 - Accessories.
- Optional Soss hinges available.

Custom Size Ranges		
	13" Deep Sides	16" Deep Sides
Width	24" – 27"	27" – 30"
Height	24" – 48"	24" – 48"
Depth	24" – 27"	27" – 30"

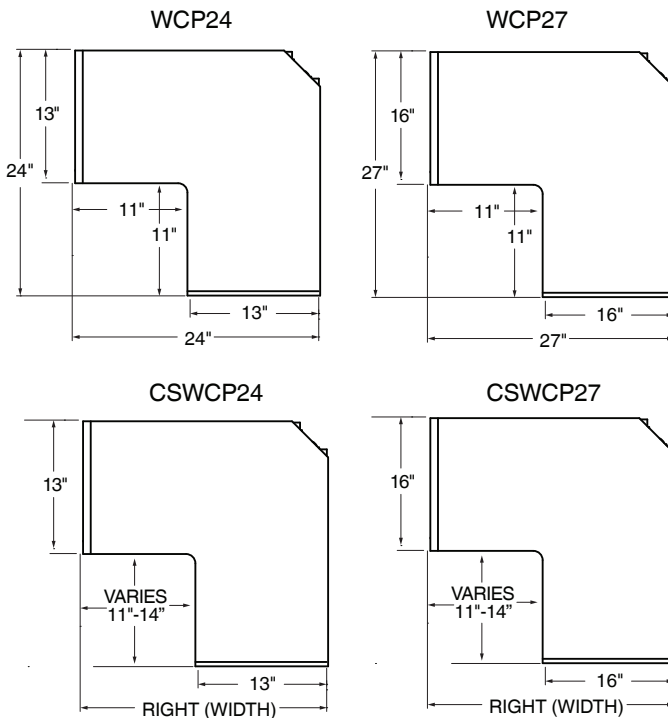

30" High	36" High	42" High
WCP2430	WCP2436	WCP2442
WCP2730	WCP2736	WCP2742

Wall Options Key: MCC = Matching Case Color NHH = No Hinge Holes NSH = No Shelf Holes NDSH = No Drawer Slide Holes OS = Omit Shelving
Design Notes:

Standard edgeband color matches cabinet interior color (Coastal White, Fog Grey or White Birch). Edgeband that matches doors/drawer fronts is available and must be specified. Upcharge applies. Use fillers when installing cabinets adjacent to walls and other cabinets to ensure adequate clearance for doors and drawers. Conestoga recommends that exposed ends be capped with 19mm thick applied decorative end panels (optional and must be specified). When this treatment is used, adjust cabinet width(s) accordingly.

WCPLS/CSWCPLS – Wall Corner Lazy Susan

Custom Size Ranges
Width: 24", 27"
Height: 30"
Depth: 24", 27"

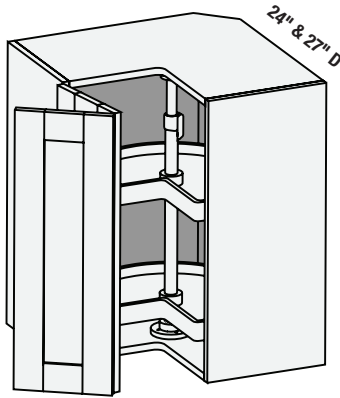

- WCPLS24 has 13" deep sides and 18" diameter susan shelves.
- WCPLS27 has 16" deep sides and 24" diameter susan shelves.
- Cabinet top and bottom is pre-drilled to accept hub assembly.
- Cabinet includes plastic susan with two independently rotating kidney shelves mounted on a center pole.
- White susan shelves feature a self-lubricating nylon bearings and tool-free height adjustment.
- Size customization is not available due to susan unit size constraints.
- Optional Soss hinges available.

WCLS2430

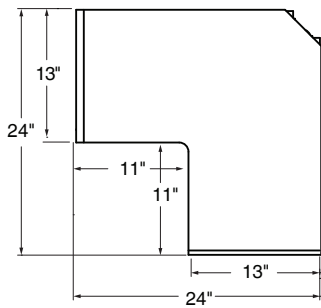

WCLS2730

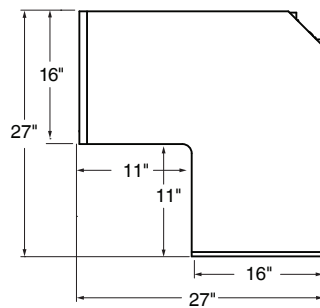

30" High

WCPLS2430

WCPLS2730

Wall Options Key: MCC = Matching Case Color NHH = No Hinge Holes NSH = No Shelf Holes NDSH = No Drawer Slide Holes OS = Omit Shelving
Design Notes:

Standard edgeband color matches cabinet interior color (Coastal White, Fog Grey or White Birch). Edgeband that matches doors/drawer fronts is available and must be specified. Upcharge applies. Use fillers when installing cabinets adjacent to walls and other cabinets to ensure adequate clearance for doors and drawers. Conestoga recommends that exposed ends be capped with 19mm thick applied decorative end panels (optional and must be specified). When this treatment is used, adjust cabinet width(s) accordingly.

W1D/CSW1D - Wall One Drawer

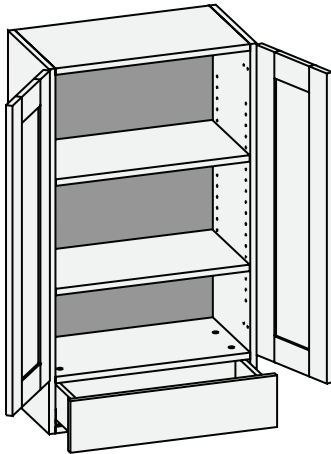

Custom Size Ranges
 Single Door Width: 12" – 24"
 Butt Door Width: 24" – 36"
 Height: 30" – 72"
 Depth: 13", 16", 18",
 21", 24"

- When height changes, upper opening height changes. Lower drawer front height fixed at 5-15/16".
- 30" – 35-15/16" high has one shelf.
- 36" – 47-15/16" high has two shelves.
- 48" – 59-15/16" high has three shelves.
- 60" – 72" high has four shelves.
- Specify single or butt doors on custom size cabinets 24" wide.

Single Door Cabinets – 13" Deep		
48" High	54" High	60" High
W1D1548	W1D1554	W1D1560
W1D1848	W1D1854	W1D1860
W1D2148	W1D2154	W1D2160
W1D2448	W1D2454	W1D2460
Butt Door Cabinets – 13" Deep		
48" High	54" High	60" High
W1D2448BD	W1D2454BD	W1D2460BD
W1D2748BD	W1D2754BD	W1D2760BD
W1D3048BD	W1D3054BD	W1D3060BD
W1D3348BD	W1D3354BD	W1D3360BD
W1D3648BD	W1D3654BD	W1D3660BD

W2D/CSW2D - Wall Two Drawer

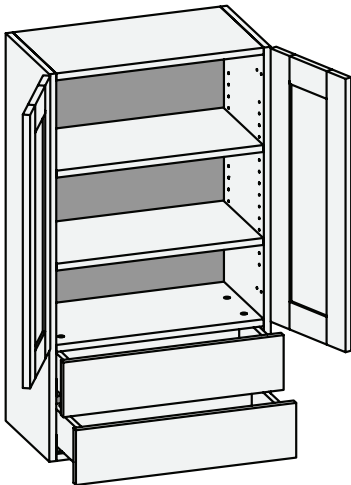

Custom Size Ranges
 Single Door Width: 12" – 24"
 Butt Door Width: 24" – 36"
 Height: 30" – 72"
 Depth: 13", 16", 18",
 21", 24"

- When height changes, upper opening height changes. Lower opening contains 2 drawer fronts with height fixed at 5-15/16".
- 30" – 41-15/16" high has one shelf.
- 42" – 47-15/16" high has two shelves.
- 48" – 59-15/16" high has three shelves.
- 60" – 72" high has four shelves.
- Specify single or butt doors on custom size cabinets 24" wide.

Single Door Cabinets – 13" Deep		
48" High	54" High	60" High
W2D1548	W2D1554	W2D1560
W2D1848	W2D1854	W2D1860
W2D2148	W2D2154	W2D2160
W2D2448	W2D2454	W2D2460
Butt Door Cabinets – 13" Deep		
48" High	54" High	60" High
W2D2448BD	W2D2454BD	W2D2460BD
W2D2748BD	W2D2754BD	W2D2760BD
W2D3048BD	W2D3054BD	W2D3060BD
W2D3348BD	W2D3354BD	W2D3360BD
W2D3648BD	W2D3654BD	W2D3660BD

Wall Options Key: MCC = Matching Case Color NHH = No Hinge Holes NSH = No Shelf Holes NDSH = No Drawer Slide Holes OS = Omit Shelving
Design Notes:

Standard edgeband color matches cabinet interior color (Coastal White, Fog Grey or White Birch). Edgeband that matches doors/drawer fronts is available and must be specified. Upcharge applies. Use fillers when installing cabinets adjacent to walls and other cabinets to ensure adequate clearance for doors and drawers. Conestoga recommends that exposed ends be capped with 19mm thick applied decorative end panels (optional and must be specified). When this treatment is used, adjust cabinet width(s) accordingly.

WOBS/CSWOBS - Wall Open Bookshelf

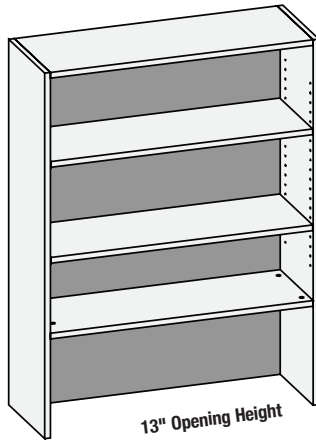

Custom Size Ranges
Width: 9" – 36"
Height: 24" – 96"
Depth: 8" – 27"

- 24" – 35-15/16" high has one fixed.
- 36" – 47-15/16" high has one fixed and one adjustable shelf.
- 48" – 59-1/16" high has one fixed and two adjustable shelves.
- 60" – 72" high has one fixed and three adjustable shelves.
- 72-1/16" – 84" has one fixed and four adjustable shelves.
- > 84" has one fixed and five adjustable shelves.

13" Deep		
48" High	54" High	60" High
WOBS1548	WOBS1554	WOBS1560
WOBS1848	WOBS1854	WOBS1860
WOBS2148	WOBS2154	WOBS2160
WOBS2448	WOBS2454	WOBS2460
WOBS2748	WOBS2754	WOBS2760
WOBS3048	WOBS3054	WOBS3060
WOBS3348	WOBS3354	WOBS3360
WOBS3648	WOBS3654	WOBS3660

WOBSCS/CSWOBSCS - Wall Open Bookshelf w/ Center Stile

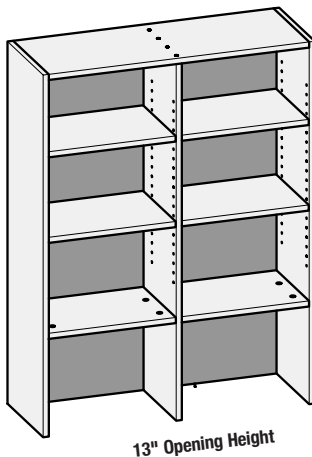

Custom Size Ranges
Width: 36" – 72"
Height: 24" – 96"
Depth: 8" – 27"

- Fixed vertical partition with independently adjustable shelves.
- 24" – 35-15/16" high has two fixed shelves.
- 36" – 47-15/16" high has two fixed and two adjustable shelves.
- 48" – 59-1/16" high has two fixed and four adjustable shelves.
- 60" – 72" high has two fixed and six adjustable shelves.
- 72-1/16" – 84" has two fixed and eight adjustable shelves.
- > 84" has two fixed and ten adjustable shelves.

13" Deep		
48" High	54" High	60" High
WOBSCS3648	WOBSCS3654	WOBSCS3660
WOBSCS3948	WOBSCS3954	WOBSCS3960
WOBSCS4248	WOBSCS4254	WOBSCS4260
WOBSCS4548	WOBSCS4554	WOBSCS4560
WOBSCS4848	WOBSCS4854	WOBSCS4860
WOBSCS5148	WOBSCS5154	WOBSCS5160
WOBSCS5448	WOBSCS5454	WOBSCS5460
WOBSCS5748	WOBSCS5754	WOBSCS5760
WOBSCS6048	WOBSCS6054	WOBSCS6060
WOBSCS6348	WOBSCS6354	WOBSCS6360
WOBSCS6648	WOBSCS6654	WOBSCS6660
WOBSCS6948	WOBSCS6954	WOBSCS6960
WOBSCS7248	WOBSCS7254	WOBSCS7260

Wall Options Key: MCC = Matching Case Color NHH = No Hinge Holes NSH = No Shelf Holes NDSH = No Drawer Slide Holes OS = Omit Shelving
Design Notes:
 Standard edgeband color matches cabinet interior color (Coastal White, Fog Grey or White Birch). Edgeband that matches doors/drawer fronts is available and must be specified. Upcharge applies. Use fillers when installing cabinets adjacent to walls and other cabinets to ensure adequate clearance for doors and drawers. Conestoga recommends that exposed ends be capped with 19mm thick applied decorative end panels (optional and must be specified). When this treatment is used, adjust cabinet width(s) accordingly.

WMB/CSWMB - Wall Microwave Built-in w/ Butt Doors

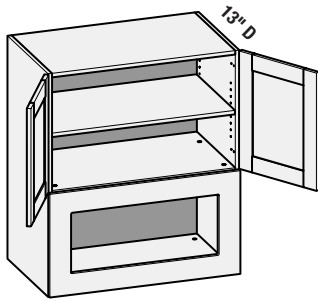

Custom Size Ranges
 Width: 24" – 36"
 Height: 30" – 72"
 Depth: 18" – 27"

- Microwave opening height is fixed at 18-1/2".
- Customer to specify height and width of microwave trim panel opening.
- Maximum microwave trim panel opening height is 13-7/16".
- Maximum microwave trim panel opening width is cabinet width minus 6".
- 42" – 48" high has one shelf.
- 48-1/16" – 66" high has two shelves.
- 66-1/16" – 72" high has three shelves.

30" High	36" High	42" High	48" High
WMB2730BD	WMB2736BD	WMB2742BD	WMB2748BD
WMB3030BD	WMB3036BD	WMB3042BD	WMB3048BD

WMWS/CSWMWS - Wall Microwave w/ Shelf w/ Butt Doors

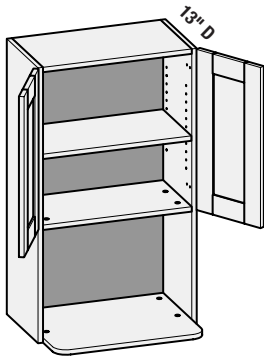

Custom Size Ranges
 Width: 24" – 36"
 Height: 30" – 72"
 Depth: 8" – 27"

- Cabinet bottom extends 6" past cabinet sides.
- When height changes, upper opening height changes. Lower opening height fixed at 16-1/2".
- Cabinet bottom is edgebanded on 3 sides.
- 30" – 41-15/16" high has no shelves.
- 42" – 48" high has one shelf.
- 48-1/16" – 60" high has two shelves.
- 60-1/16" – 72" high has three shelves.

30" High	36" High	42" High	48" High
WMWS2430BD	WMWS2436BD	WMWS2442BD	WMWS2448BD
WMWS2730BD	WMWS2736BD	WMWS2742BD	WMWS2748BD
WMWS3030BD	WMWS3036BD	WMWS3042BD	WMWS3048BD

Wall Options Key: MCC = Matching Case Color NHH = No Hinge Holes NSH = No Shelf Holes NDSH = No Drawer Slide Holes OS = Omit Shelving
Design Notes:

Standard edgeband color matches cabinet interior color (Coastal White, Fog Grey or White Birch). Edgeband that matches doors/drawer fronts is available and must be specified. Upcharge applies. Use fillers when installing cabinets adjacent to walls and other cabinets to ensure adequate clearance for doors and drawers. Conestoga recommends that exposed ends be capped with 19mm thick applied decorative end panels (optional and must be specified). When this treatment is used, adjust cabinet width(s) accordingly.

TTW/CSTTW - Two Tiered Wall

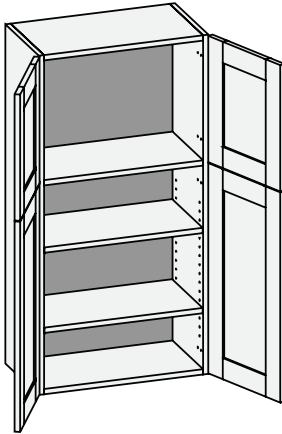

Custom Size Ranges
 Single Door Width: 12" – 24"
 Butt Door Width: 24" – 36"
 Height: 48" – 72"
 Depth: 8" – 27"

- When height changes, lower opening height changes. Upper opening height fixed at 17".
- Lower section designed to align with adjacent wall cabinets. Add 18" to adjacent cabinet to determine TTW cabinet height.
- 48" – 60" high has two shelves.
- 60-1/16" – 72" high has three shelves.
- Specify single or butt doors on custom size cabinets 24" wide.

Single Door Cabinets – 13" Deep		Butt Door Cabinets – 13" Deep	
48" High		48" High	
TTW1248	TTW2148	TTW2748 BD	TTW3948 BD
TTW1548	TTW2448	TTW3048 BD	TTW4248 BD
TTW1848		TTW3348 BD	TTW4548 BD
		TTW3648 BD	TTW4848 BD

TTWCSE/CSTTWSE - Two Tiered Wall Corner Single Entry

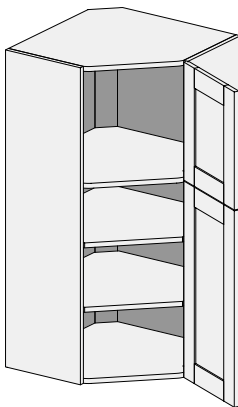

Custom Size Ranges
 Width: 24", 27"
 Height: 48" – 72"
 Depth: 24", 27"

- TTWCSE24 units have 13" deep sides.
- TTWCSE27 units have 16" deep sides.
- Susan Option is not available.
- Lower section designed to align with adjacent wall cabinets. Add 18" to adjacent cabinet to determine TTW cabinet height.
- When height changes, lower opening height changes. Opening height above mid-floor fixed at 17".
- 48" – 60" high has two shelves.
- 60-1/16" – 72" high has three shelves.

48" High
TTWCSE2448
TTWCSE2748

TTWCP/CSTTWCP - Two Tiered Wall Corner Pie Cut

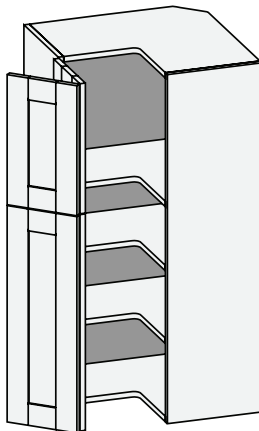

Custom Size Ranges
 Width: 24", 27"
 Height: 48" – 72"
 Depth: 24", 27"

- TTWCP24 units have 13" deep sides.
- TTWCP27 units have 16" deep sides.
- Susan Option is not available.
- Lower section designed to align with adjacent wall cabinets. Add 18" to adjacent cabinet to determine TTW cabinet height.
- When height changes, lower opening height changes. Opening height above mid-floor fixed at 17".
- 48" – 60" high has two shelves.
- 60-1/16" – 72" high has three shelves.

48" High
TTWCP2448
TTWCP2748

Wall Options Key: MCC = Matching Case Color NHH = No Hinge Holes NSH = No Shelf Holes NDSH = No Drawer Slide Holes OS = Omit Shelving
Design Notes:

Standard edgeband color matches cabinet interior color (Coastal White, Fog Grey or White Birch). Edgeband that matches doors/drawer fronts is available and must be specified. Upcharge applies. Use fillers when installing cabinets adjacent to walls and other cabinets to ensure adequate clearance for doors and drawers. Conestoga recommends that exposed ends be capped with 19mm thick applied decorative end panels (optional and must be specified). When this treatment is used, adjust cabinet width(s) accordingly.

CSWHKXS - Wall w/HK-XS Lift System

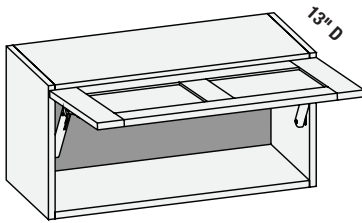

Custom Size Ranges
Width: 15" – 42"
Height: 12" – 24"
Depth: 8" – 27"

- Preconfigured units include Blum HK-XS Series lift system hardware and Blum hinges.
- Door weight and design determine the strength and quantity of lift mechanisms provided.
- Cabinet width 15" – 24" are single panel door designs. 24-1/16" – 42" are two panels side by side. Upcharges for two panel door applies.
- 12" – 18" high has no shelves.
- 18-1/16" – 24" high has one shelf.

14

Vesta Wall Cabinets

CSWHL - Wall w/ AVENTOS HL top Lift System

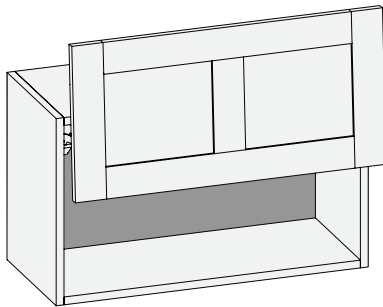

Custom Size Ranges
Width: 15" – 42"
Height: 12" – 33"
Depth: 12" – 27"
Door Height: 11-3/4" – 22-3/4"

- Preconfigured units include Blum AVENTOS HL top series lift system hardware.
- Door weight and design determine the lift kit provided.
- Door minimum and maximum height cannot be exceeded.
- Cabinet may not be valid if system calculated door weight exceeds minimum or maximum value.
- Cabinet width 15" – 24" are single panel door designs. 24-1/16" – 42" are two panels side by side door designs. Upcharges for 2 panel door apply.
- 12" – 18" high has no shelves.
- 18-1/16" – 23" high has one shelf.

CSWHK - Wall w/ AVENTOS HK top Lift System

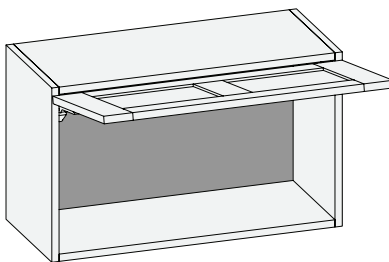

Custom Size Ranges
Width: 12" – 42"
Height: 8" – 24"
Depth: 10" – 27"

- Preconfigured units include Blum AVENTOS HL top series lift system hardware.
- Door weight and design determine the lift kit provided.
- Door minimum and maximum height cannot be exceeded.
- Cabinet may not be valid if system calculated door weight exceeds minimum or maximum value.
- Cabinet width 15" – 24" are single panel door designs. 24-1/16" – 42" are two panels side by side door designs. Upcharges for 2 panel door apply.
- 10" – 18" high has no shelves.
- 18-1/16" – 23" high has one shelf.

Wall Options Key: MCC = Matching Case Color NHH = No Hinge Holes NSH = No Shelf Holes NDSH = No Drawer Slide Holes OS = Omit Shelving
Design Notes:

Standard edgeband color matches cabinet interior color (Coastal White, Fog Grey or White Birch). Edgeband that matches doors/drawer fronts is available and must be specified. Upcharge applies. Use fillers when installing cabinets adjacent to walls and other cabinets to ensure adequate clearance for doors and drawers. Conestoga recommends that exposed ends be capped with 19mm thick applied decorative end panels (optional and must be specified).

When this treatment is used, adjust cabinet width(s) accordingly.

CSWAC – Custom Size Wall Appliance Cabinet

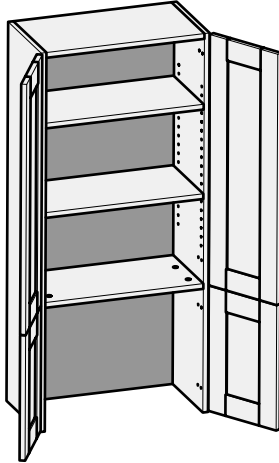

Custom Size Ranges
 Single Door Width: 12" – 24"
 Butt Door Width: 24" – 36"
 Height: 12" – 96"
 Depth: 8" – 30"
 Top Cab Height: 6" – 90"

- When ordering CSWAC specify the desired top cabinet height. On 1-1/4" & 1-3/8" overlay applications, CWS will adjust the mid-floor location to ensure doors align with adjacent Wall cabinet doors.
- Account for the countertop thickness when specifying overall cabinet height to ensure doors align properly.
- When ordering loose parts for this cabinet, use the BOM and specify the desired overlay to ensure the correct parts are ordered.
- Specify single or butt doors on custom size cabinets 24" wide.
- Shelf quantity is calculated for each opening height.
- Height < 18-1/16" high has no shelves.
- Height 18-1/16" – 24" high has one shelf.
- Height 24-1/16" - 36" high has two shelves.
- Height 36-1/16" – 48" high has three shelves.
- Height 48-1/16" – 60" high has four shelves.
- Height 60-1/16" – 72" high has five shelves.
- Height 72-1/16" – 84" high has six shelves.
- Height > 84" high has seven shelves.

CSWACHL - Wall Appliance Cabinet w/ AVENTOS HL top Lift System

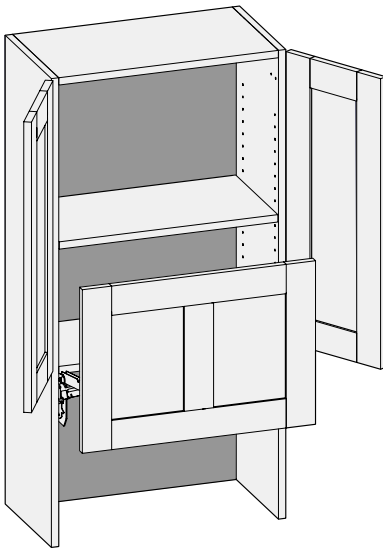

Custom Size Ranges
 Single Door Width: 15" – 24"
 Butt Door Width: 24" – 42"
 Height: 24" – 96"
 Depth: 12" – 30"
 Top Cab Height: 6" - 96"
 Bottom Door Height:
 11-3/4" - 22-3/4"

- Preconfigured CSWACHL units include Blum AVENTOS HL top series lift system hardware.
- Lower door weight and design determine the lift kit provided.
- Lower door minimum and maximum height cannot be exceeded.
- Cabinet may not be valid if system calculated lower door weight exceeds minimum or maximum value.
- Cabinet width 15" – 24" are single panel lower door designs. 24-1/16" – 36" are two panels side by side lower door designs. Upcharges for 2 panel door apply.

Wall Options Key: MCC = Matching Case Color NHH = No Hinge Holes NSH = No Shelf Holes NDSH = No Drawer Slide Holes OS = Omit Shelving
Design Notes:
 Standard edgeband color matches cabinet interior color (Coastal White, Fog Grey or White Birch). Edgeband that matches doors/drawer fronts is available and must be specified. Upcharge applies. Use fillers when installing cabinets adjacent to walls and other cabinets to ensure adequate clearance for doors and drawers. Conestoga recommends that exposed ends be capped with 19mm thick applied decorative end panels (optional and must be specified). When this treatment is used, adjust cabinet width(s) accordingly.

Vesta Base Cabinet Standard Features and Options

The features below are standard on all Base cabinets where the design permits. Standard features can be omitted as needed. The option to omit standard features as well as add design options can be quickly referenced at the bottom of each page in the Base Cabinet Section labeled “Base Options Key”. For detailed descriptions and images of the options, see Options, Section 20 of this manual. Standard features and options are available on all Base cabinets unless specifically noted as **Unavailable Options**.

Edgeband – Our Base cabinets sides, tops, bottoms, mid-floors, stringers and shelves are edgebanded on the front edges only. Interior parts such as uprights or other support members are edgebanded on visible edges. Edgeband color must be specified to either match the case color (standard offering) or door color if applicable (upcharge applies). When Door Matching Edgeband Option is selected the front edges of the sides, top, bottom and mid-floor are edgebanded using the door color. The edgeband on the shelves and interior parts will match the interior case color. Door Matching Edgeband Option is available with all Allure DLV, Intrigue TTS, Strata TTS, Vogue TTS, Synchronicity High Gloss and Super Matte colors, as well as wood edgeband in Cherry, Hard Maple, Paint Grade, Red Oak, Rift Cut White Oak and Walnut.

5mm Shelf Holes – 5mm Shelf Holes are pre-drilled on 32mm centers on all cabinets with shelves. **No Shelf Holes (NSH)** and **Omit Shelving (OS)** Options are available on Base cabinets with shelves. If both the No Shelf Holes and Omit Shelving Options are required, both must be individually specified.

Hinge Hole Drilling – All Base cabinets eligible to receive doors will include Blum Frameless INSERTA Hinges and are pre-drilled with 5mm holes to accept the EXPANDO Mounting Plates. A **No Hinge Hole (NHH)** Option is available on any Base cabinet that would typically include doors. Cabinet hinges can also be omitted, but must be changed from the default Yes to No. The No Hinge Hole Option does not remove hinges; No Hinges must be specified.

Drawer Slide Hole Drilling – All Base cabinets that include drawer boxes also include Blum TANDEM Drawer Slides and are pre-drilled with 5mm holes for quick and easy installation. The **No Drawer Slide Hole (NDSH)** Option is available only on cabinets with drawer boxes. Drawer slides can be omitted, but must be changed from the default of Yes to No. The No Drawer Slide Hole Option does not automatically remove drawer slides; No Drawer Slides must be specified.

Toe Kick Notch – Most Base cabinets come with a 3-3/4” x 4” Toe Kick Notch standard. Cabinets with a toe kick are available with either the **Flush Toe (FT)** and **Square Toe Notch (STN)** Options. The Flush Toe Option removes the toe kick from the cabinet and brings the toe backer flush with the cabinet front edge. The Square Toe Notch Option makes the intersecting corner of the Toe Notch 90° to aid in toeboard installation.

Matching Case Color (MCC) – With the Matching Case Color Option, the door and drawer front color matches the cabinet interior, exterior, and edgeband. The Matching Case Color Option is available with most Base cabinets and produced in all published Intrigue TTS, Strata TTS and Vogue TTS colors, as well as wood edgeband in Cherry, Hard Maple, Paint Grade, Red Oak, Rift Cut White Oak and Walnut.

Loose Toe Platform (LTP) – With the Loose Toe Platform Option, enter the desired cabinet height, deductions for the toe platform are calculated by our software which will automatically reduce by 4” and is produced without a toe kick. A 4” platform is provided to achieve the desired finished cabinet height. The Loose Toe Platform is available with most Base cabinets. Flush Toe and Square Toe Notch Options are not available with Loose Toe Platform.

Base Options Key: FT = Flush Toe LTP = Loose Toe Platform STN = Square Toe Notch MCC = Matching Case Color NHH = No Hinge Holes
NSH = No Shelf Holes NDSH = No Drawer Slide Holes OS = Omit Shelving

Design Notes:

Standard edgeband color matches cabinet interior color (Coastal White, Fog Grey or White Birch). If eligible, edgeband that matches doors/drawer fronts must be specified. Upcharge applies. Use fillers when installing cabinets adjacent to walls and other cabinets to ensure adequate clearance for doors and drawers. Conestoga recommends that exposed ends be capped with 19mm thick applied decorative end panels (optional and must be specified). When this treatment is used, adjust cabinet width(s) accordingly.

B/CSB - Base

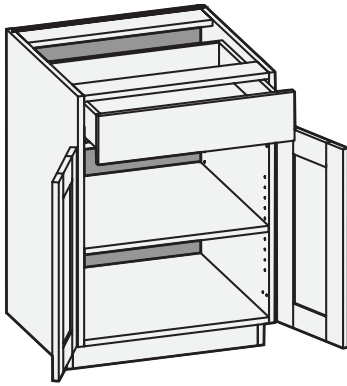

Custom Size Ranges
 Single Door Width: 12" – 24"
 Butt Door Width: 24" – 36"
 Height: 31-1/2" – 42"
 Depth: 12", 13", 15", 16", 18",
 21", 24", 27", 30"

- When height changes, lower opening height changes. Drawer front height fixed at 5-15/16".
- Specify single or butt doors on custom size cabinets 24" wide.

24" Deep			
Single Door Cabinets		Butt Door Cabinets	
B1234.5	B2134.5	B2434.5BD	B3334.5BD
B1534.5	B2434.5	B2734.5BD	B3634.5BD
B1834.5		B3034.5BD	

BTCP/CSBTCP - Base w/Trash Can Pull-Out

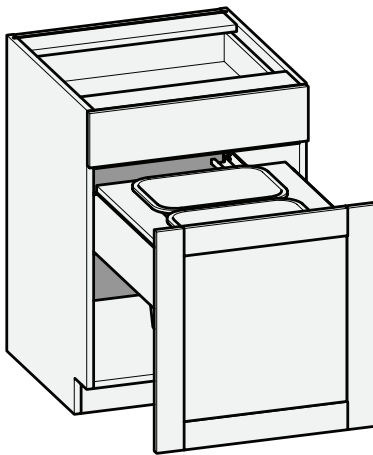

Custom Size Ranges
 Width: 18" – 27"
 Height: 31-1/2" – 34-1/2"
 Depth: 24"

- Cabinet depth is 24". Depth customization is not available due to Trash Can Pull-Out and hardware requirements.
- Trash Can Pull-Out unit is prefinished Natural Birch sides with a Hard Maple plywood top.
- Single can, double cans or units with no cut-outs are available.
- Pull-out unit is 6" high to accommodate door mounting.
- Units include 28 quart grey waste cans.
- Units 18" – 23-15/16" wide have one can; units 24" – 27" wide include 2 cans. When ordering custom size cabinets within these ranges, specify single can, double cans or no cut-outs.
- When cabinet height changes, lower opening height changes. Drawer front height fixed at 5-15/16".

24" Deep	
Single Can 34-1/2" High	Double Can 34-1/2" High
BTCP1834.5	BTCP2434.5
BTCP2134.5	BTCP2734.5

Base Options Key: FT = Flush Toe LTP = Loose Toe Platform STN = Square Toe Notch MCC = Matching Case Color NHH = No Hinge Holes
 NSH = No Shelf Holes NDSH = No Drawer Slide Holes OS = Omit Shelving

Design Notes:

Standard edgeband color matches cabinet interior color (Coastal White, Fog Grey or White Birch). If eligible, edgeband that matches doors/drawer fronts must be specified. Upcharge applies. Use fillers when installing cabinets adjacent to walls and other cabinets to ensure adequate clearance for doors and drawers. Conestoga recommends that exposed ends be capped with 19mm thick applied decorative end panels (optional and must be specified). When this treatment is used, adjust cabinet width(s) accordingly.

BS/CSBS - Base Sink w/Butt Doors

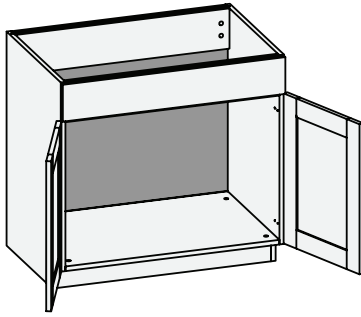

Custom Size Ranges
 Width: 24" – 48"
 Height: 31-1/2" – 42"
 Depth: 18" – 30"

- False drawer front, height is fixed at 5-15/16".
- When height changes, lower opening height changes.
- Specify single or butt doors on custom size cabinets 24" wide.

24" Deep	
BS2434.5BD	BS3334.5BD
BS2734.5BD	BS3634.5BD
BS3034.5BD	

ASB/CSASB – Apron Sink Base

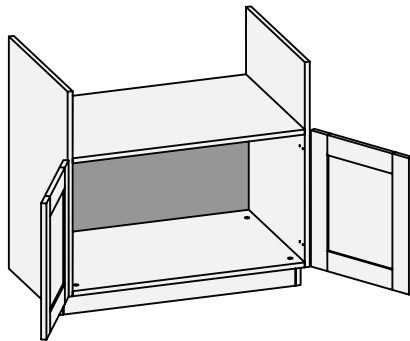

Custom Size Ranges
 Width: 24" – 36"
 Height: 31-1/2" – 42"
 Depth: 18" – 30"

- When ordering Apron Sink Base Cabinet specify top sink bowl opening height.
- Order Trim Panels (TP/CSTP) as needed to trim out around the sink. See details in Section 19, Accessories.
- Reveal between top of doors and mid-floor is 1/8".

24" Deep	
ASB2434.5BD	ASB3334.5BD
ASB2734.5BD	ASB3634.5BD
ASB3034.5BD	

BSFD/CSBSFD – Base Sink Full Door w/ Butt Doors

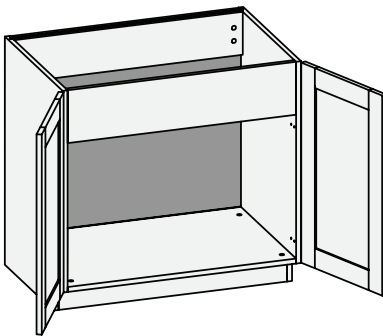

Custom Size Ranges
 Width: 24" – 36"
 Height: 31-1/2" – 34-1/2"
 Depth: 18" – 30"

- 8" high apron conceals sink bowl, accommodates hinges and matches cabinet edgeband color.
- Specify single or butt doors on custom size cabinets 24" wide.

24" Deep	
BSFD2434.5BD	BSFD3334.5BD
BSFD2734.5BD	BSFD3634.5BD
BSFD3034.5BD	

Base Options Key: FT = Flush Toe LTP = Loose Toe Platform STN = Square Toe Notch MCC = Matching Case Color NHH = No Hinge Holes
 NSH = No Shelf Holes NDSH = No Drawer Slide Holes OS = Omit Shelving

Design Notes:

Standard edgeband color matches cabinet interior color (Coastal White, Fog Grey or White Birch). If eligible, edgeband that matches doors/drawer fronts must be specified. Upcharge applies. Use fillers when installing cabinets adjacent to walls and other cabinets to ensure adequate clearance for doors and drawers. Conestoga recommends that exposed ends be capped with 19mm thick applied decorative end panels (optional and must be specified). When this treatment is used, adjust cabinet width(s) accordingly.

BFD/CSBFD - Base Full Door

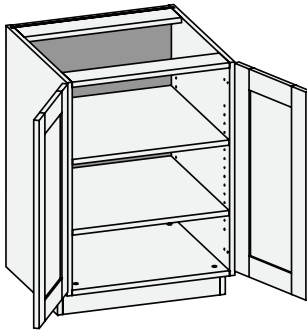

Custom Size Ranges
 Single Door Width: 9" – 24"
 Butt Door Width: 24" – 36"
 Height: 10" – 42"
 Depth: 12" – 30"

- 10" – 22" high has no shelves.
- 22-1/16" – 28" high has one shelf.
- 28-1/16" – 40" high has two shelves.
- 40-1/16" – 42" high has three shelves.
- Specify single or butt doors on custom size cabinets 24" wide.

24" Deep			
Single Door Cabinets		Butt Door Cabinets	
BFD0934.5	BFD1834.5	BFD2434.5BD	BFD3334.5BD
BFD1234.5	BFD2134.5	BFD2734.5BD	BFD3634.5BD
BFD1534.5	BFD2434.5	BFD3034.5BD	

13" Deep			
Single Door Cabinets		Butt Door Cabinets	
BWD1234.5	BWD2134.5	BWD2434.5BD	BWD3334.5BD
BWD1534.5	BWD2434.5	BWD2734.5BD	BWD3634.5BD
BWD1834.5		BWD3034.5BD	

BFDRO/CSBFDRO - Base Full Door Roll-Out w/Butt Doors

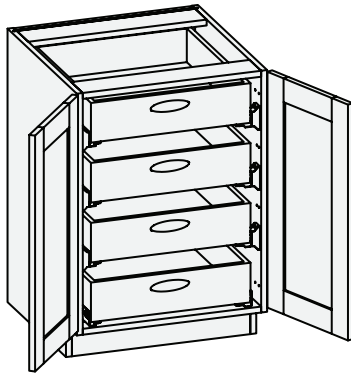

Custom Size Ranges
 Width: 24" – 36"
 Height: 31-1/2" – 34-1/2"
 Depth: 18", 21", 24"

- Units are configured with four 5" high drawer boxes. Interior panels are pre-drilled for drawer slide placement and installation.
- Roll-out drawers include hand pulls. Specify Standard, Circle or Ellipse (shown) pull.

24" Deep			
Single Door Cabinets		Butt Door Cabinets	
BFDRO1234.5	BFDRO2134.5	BFDRO2434.5BD	BFDRO3334.5BD
BFDRO1534.5	BFDRO2434.5	BFDRO2734.5BD	BFDRO3634.5BD
BFDRO1834.5		BFDRO3034.5BD	

Base Options Key: FT = Flush Toe LTP = Loose Toe Platform STN = Square Toe Notch MCC = Matching Case Color NHH = No Hinge Holes
 NSH = No Shelf Holes NDSH = No Drawer Slide Holes OS = Omit Shelving

Design Notes:

Standard edgeband color matches cabinet interior color (Coastal White, Fog Grey or White Birch). If eligible, edgeband that matches doors/drawer fronts must be specified. Upcharge applies. Use fillers when installing cabinets adjacent to walls and other cabinets to ensure adequate clearance for doors and drawers. Conestoga recommends that exposed ends be capped with 19mm thick applied decorative end panels (optional and must be specified). When this treatment is used, adjust cabinet width(s) accordingly.

BOU/CSBOU – Base Open Unit

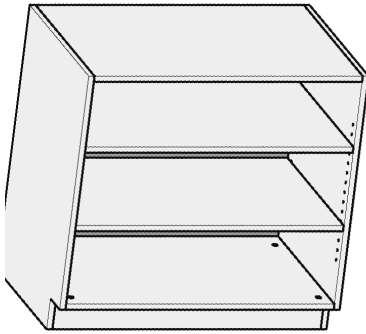

Custom Size Ranges
Width: 9" – 48"
Height: 10" – 48"
Depth: 8" – 30"

- 10" – 22" high has no shelves.
- 22-1/16" – 28" high has one shelf.
- 28-1/16" – 40" high has two shelves.
- 40-1/16" – 48" high has three shelves.

24" Deep	
BOU3034.5	BOU4234.5
BOU3334.5	BOU4534.5
BOU3634.5	BOU4834.5
BOU3934.5	

Base Options Key: FT = Flush Toe LTP = Loose Toe Platform STN = Square Toe Notch MCC = Matching Case Color NHH = No Hinge Holes
NSH = No Shelf Holes NDSH = No Drawer Slide Holes OS = Omit Shelving

Design Notes:

Standard edgeband color matches cabinet interior color (Coastal White, Fog Grey or White Birch). If eligible, edgeband that matches doors/drawer fronts must be specified. Upcharge applies. Use fillers when installing cabinets adjacent to walls and other cabinets to ensure adequate clearance for doors and drawers. Conestoga recommends that exposed ends be capped with 19mm thick applied decorative end panels (optional and must be specified). When this treatment is used, adjust cabinet width(s) accordingly.

CSB1D – Base One Drawer

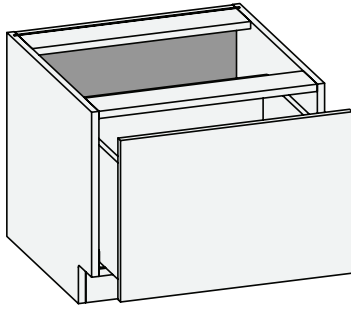

Custom Size Ranges
 Width: 12" – 36"
 Height: 12" - 21"
 Depth: 12", 13", 15, 16", 18",
 21", 24", 27", 30"

- When height changes, drawer box height changes proportionately.

B2D/CSB2D - Base Two Drawer

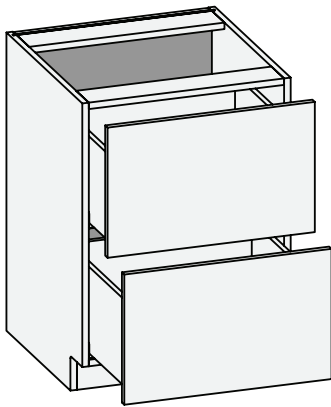

Custom Size Ranges
 Width: 12" – 39"
 Height: 31-1/2" – 34-1/2"
 Depth: 12", 13", 15", 16",
 18", 21", 24", 27",
 30"

- When height changes, both drawers remain equal in height.

24" Deep	
B2D1234.5	B2D2734.5
B2D1534.5	B2D3034.5
B2D1834.5	B2D3334.5
B2D2134.5	B2D3634.5
B2D2434.5	B2D3934.5

B2DRO/CSB2DRO - Base Two Drawer Roll-Out

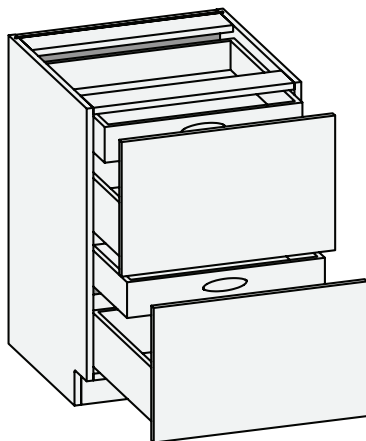

Custom Size Ranges
 Width: 12" – 39"
 Height: 31-1/2" – 34-1/2"
 Depth: 12", 13", 15", 16",
 18", 21", 24", 27",
 30"

- Units are configured with 4" high roll-out drawers over 6" high conventional drawer box in each opening.
- Roll-out drawers include hand pulls. Specify Standard, Circle or Ellipse (shown) pull.
- When height changes, both drawer heights are equal.

24" Deep	
B2DRO1234.5	B2DRO2734.5
B2DRO1534.5	B2DRO3034.5
B2DRO1834.5	B2DRO3334.5
B2DRO2134.5	B2DRO3634.5
B2DRO2434.5	B2DRO3934.5

Base Options Key: FT = Flush Toe LTP = Loose Toe Platform STN = Square Toe Notch MCC = Matching Case Color NHH = No Hinge Holes
 NSH = No Shelf Holes NDSH = No Drawer Slide Holes OS = Omit Shelving

Design Notes:

Standard edgeband color matches cabinet interior color (Coastal White, Fog Grey or White Birch). If eligible, edgeband that matches doors/drawer fronts must be specified. Upcharge applies. Use fillers when installing cabinets adjacent to walls and other cabinets to ensure adequate clearance for doors and drawers. Conestoga recommends that exposed ends be capped with 19mm thick applied decorative end panels (optional and must be specified). When this treatment is used, adjust cabinet width(s) accordingly.

B3D/CSB3D - Base Three Drawer

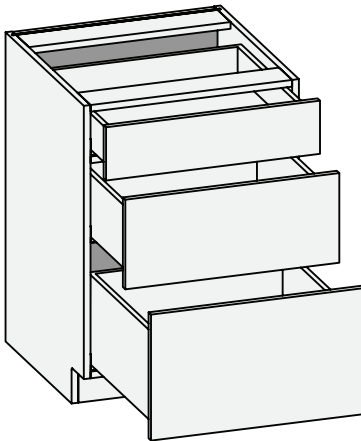

Custom Size Ranges
 Width: 12" – 39"
 Height: 31-1/2" – 34-1/2"
 Depth: 12", 13", 15", 16",
 18", 21", 24", 27",
 30"

- When height changes, lower drawer height changes. Upper and middle drawer heights fixed at 5-15/16" and 10".

24" Deep	
B3D1234.5	B3D2734.5
B3D1534.5	B3D3034.5
B3D1834.5	B3D3334.5
B3D2134.5	B3D3634.5
B3D2434.5	B3D3934.5

B3DEH/CSB3DEH - Base Three Drawer w/Two Equal Height Lower Drawers

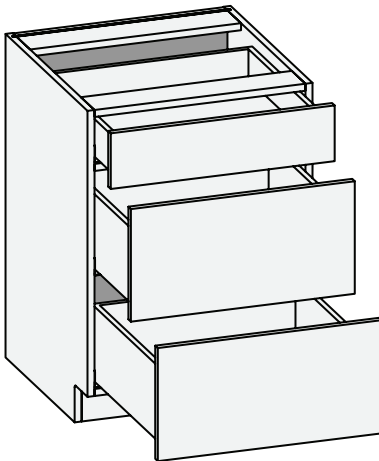

Custom Size Ranges
 Width: 12" – 39"
 Height: 31-1/2" – 34-1/2"
 Depth: 12", 13", 15", 16",
 18", 21", 24", 27",
 30"

- When height changes, both lower drawer height changes. Upper drawer height fixed at 5-15/16".

24" Deep	
B3DEH1234.5	B3DEH2734.5
B3DEH1534.5	B3DEH3034.5
B3DEH1834.5	B3DEH3334.5
B3DEH2134.5	B3DEH3634.5
B3DEH2434.5	B3DEH3934.5

B4D/CSB4D - Base Four Drawer

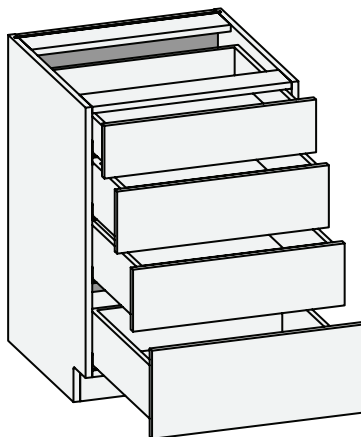

Custom Size Ranges
 Width: 12" – 39"
 Height: 31-1/2" – 34-1/2"
 Depth: 12", 13", 15", 16",
 18", 21", 24", 27",
 30"

- When height changes, lower drawer height changes. Upper drawer front height fixed at 5-15/16". Middle drawer fronts fixed at 7" high.

24" Deep	
B4D1234.5	B4D2134.5
B4D1534.5	B4D2434.5
B4D1834.5	B4D2734.5

Base Options Key: FT = Flush Toe LTP = Loose Toe Platform STN = Square Toe Notch MCC = Matching Case Color NHH = No Hinge Holes
 NSH = No Shelf Holes NDSH = No Drawer Slide Holes OS = Omit Shelving

Design Notes:

Standard edgeband color matches cabinet interior color (Coastal White, Fog Grey or White Birch). If eligible, edgeband that matches doors/drawer fronts must be specified. Upcharge applies. Use fillers when installing cabinets adjacent to walls and other cabinets to ensure adequate clearance for doors and drawers. Conestoga recommends that exposed ends be capped with 19mm thick applied decorative end panels (optional and must be specified). When this treatment is used, adjust cabinet width(s) accordingly.

BCP/CSBCP – Base Corner Pie Cut

Custom Size Ranges
 Width: 33" – 42"
 Height: 31-1/2" – 42"
 Depth: 33" – 42"

- Shelf mounted wood susan shelves are available. See Section 19 – Accessories.
- CSBCP available with custom size legs. Specified width (left dimension) and depth (right dimension). Side dimension remains fixed; pie cut opening adjusts as size changes.
- Minimum entry opening width required for BCP3634.5 is 35" (doorways, hallways etc.).
- Optional Soss hinges available.
- Unavailable Option: LTP

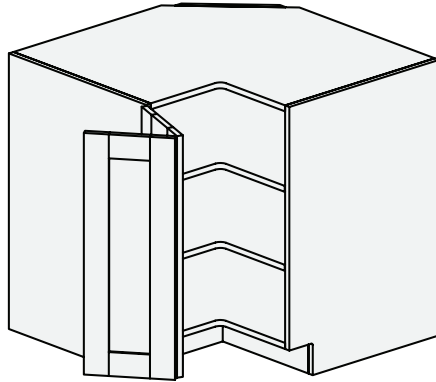

24" Deep Side
BCP3334.5
BCP3634.5

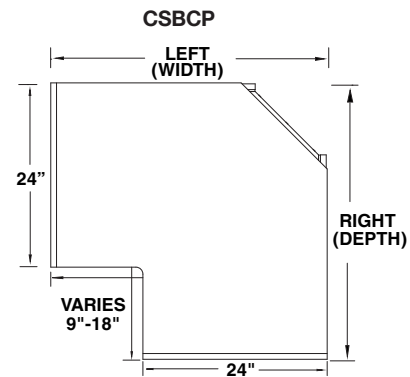
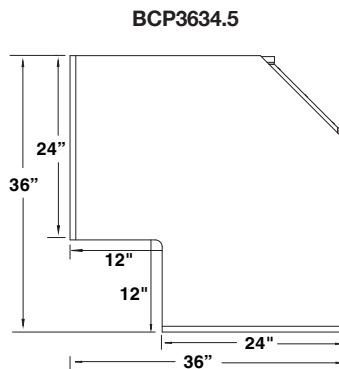
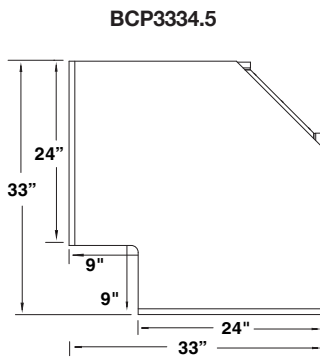

Base Options Key: FT = Flush Toe LTP = Loose Toe Platform STN = Square Toe Notch MCC = Matching Case Color NHH = No Hinge Holes
 NSH = No Shelf Holes NDSH = No Drawer Slide Holes OS = Omit Shelving

Design Notes:

Standard edgeband color matches cabinet interior color (Coastal White, Fog Grey or White Birch). If eligible, edgeband that matches doors/drawer fronts must be specified. Upcharge applies. Use fillers when installing cabinets adjacent to walls and other cabinets to ensure adequate clearance for doors and drawers. Conestoga recommends that exposed ends be capped with 19mm thick applied decorative end panels (optional and must be specified). When this treatment is used, adjust cabinet width(s) accordingly.

BCPLS – Base Corner Pie Cut Lazy Susan

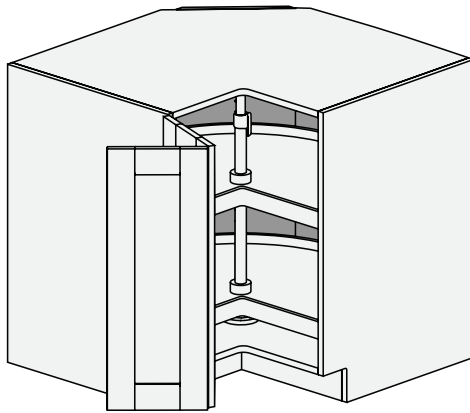

Custom Size Ranges
Width: 36"
Height: 34-1/2"
Depth: 36"

- Cabinet top and bottom is pre-drilled to accept hub assembly. Location and installation are greatly simplified.
- Cabinet includes 32" diameter plastic susan with two independently rotating kidney shelves mounted on a center pole.
- White susan shelves feature a self-lubricating nylon bearing and tool-free height adjustment.
- Height customization is not available due to susan size constraints.
- Minimum entry opening width required is 35" (doorways, hallways, etc.).
- Optional Soss hinges available.
- Unavailable Option: LTP

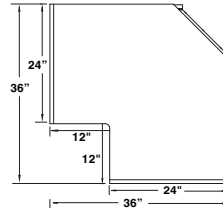

24" Deep Side

BCPLS3634.5

BCFD/CSBCFD - Base Corner Full Door

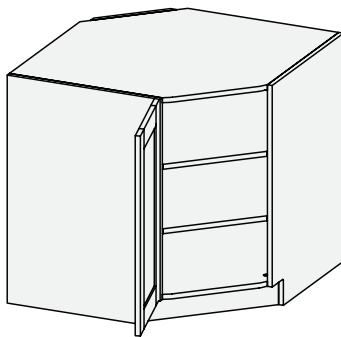

Custom Size Ranges
Width: 36"
Height: 31-1/2" – 42"
Depth: 36"

- 31-1/2" – 40" high has 2 shelves
- 40-1/16" – 42" high has 3 shelves.
- Shelf mounted wood susan shelves are available. See Section 19 – Accessories.
- Minimum entry opening width required is 35" (doorways, hallways, etc.).
- Unavailable Option: LTP

24" Deep Side

BCFD3634.5

BCFDLS - Base Corner Full Door w/ Lazy Susan

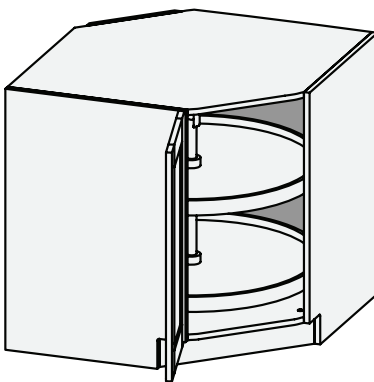

Custom Size Ranges
Width: 36"
Height: 34-1/2"
Depth: 36"

- Cabinet top and bottom is pre-drilled to accept hub assembly. Location and installation are greatly simplified.
- Cabinet includes 32" diameter plastic susan with two independently rotating shelves mounted on a center pole.
- White susan shelves feature a self-lubricating nylon bearing and tool-free height adjustment.
- Size customization is not available due to susan size constraints.
- Minimum entry opening width required is 35" (doorways, hallways, etc.).
- Unavailable Option: LTP

24" Deep Side

BCFDLS 3634.5

Base Options Key: FT = Flush Toe LTP = Loose Toe Platform STN = Square Toe Notch MCC = Matching Case Color NHH = No Hinge Holes
NSH = No Shelf Holes NDSH = No Drawer Slide Holes OS = Omit Shelving

Design Notes:

Standard edgeband color matches cabinet interior color (Coastal White, Fog Grey or White Birch). If eligible, edgeband that matches doors/drawer fronts must be specified. Upcharge applies. Use fillers when installing cabinets adjacent to walls and other cabinets to ensure adequate clearance for doors and drawers. Conestoga recommends that exposed ends be capped with 19mm thick applied decorative end panels (optional and must be specified). When this treatment is used, adjust cabinet width(s) accordingly.

BBCR/CSBBCR – Base Blind Cabinet Blind Right

Custom Size Ranges
 Width: 36" – 48"
 Height: 31-1/2" – 42"
 Depth: 12", 13", 15", 16", 18",
 21", 24", 27", 30"
 Functional opening: 12" – 24"

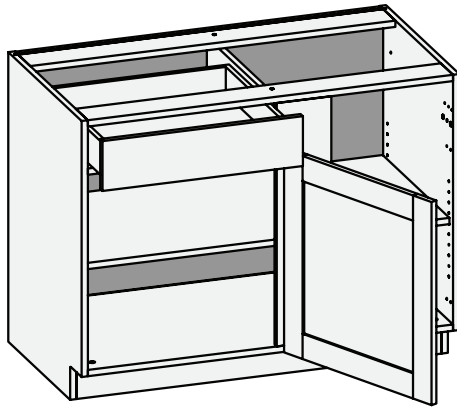

6-1/2" Wide Upright

- Overall cabinet size is the actual width specified.
- Blind section is on the right.
- Specify functional opening width between 12" and 24".
- Door is always hinged on center upright.
- When height changes, lower opening height changes. Drawer front height fixed at 5-15/16".
- Minimum exposed blind amount for all overlays is 2-1/2" to ensure adequate clearance for adjacent door and drawer function.
- Excessive hardware projection may require a greater amount of exposed blind. Design and install accordingly.
- Specify single or butt door when functional opening is 22-1/2".

24" Deep	
BBCR3634.5	BBCR4534.5
BBCR3934.5	BBCR4834.5
BBCR4234.5	

BBCL/CSBBCL – Base Blind Cabinet Blind Left

Custom Size Ranges
 Width: 36" – 48"
 Height: 31-1/2" – 42"
 Depth: 12", 13", 15", 16", 18",
 21", 24", 27", 30"
 Functional opening: 12" – 24"

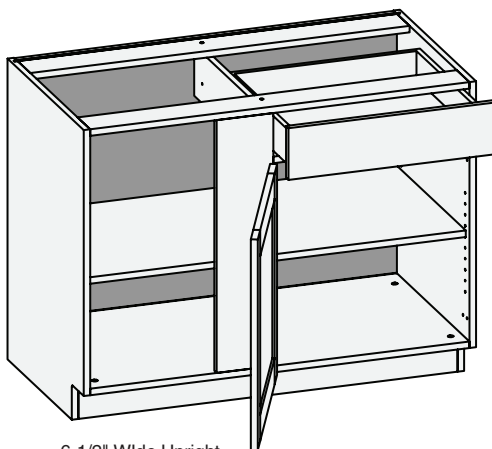

6-1/2" Wide Upright

- Overall cabinet size is the actual width specified.
- Blind section is on the left.
- Specify functional opening width between 12" and 24".
- Door is always hinged on center upright for all overlays.
- When height changes, lower opening height changes. Drawer front height fixed at 5-15/16".
- Minimum exposed blind amount for all overlays is 2-1/2" to ensure adequate clearance for adjacent door and drawer function.
- Excessive hardware projection may require a greater amount of exposed blind. Design and install accordingly.
- Specify single or butt door when functional opening is 22-1/2".

24" Deep	
BBCL3634.5	BBCL4534.5
BBCL3934.5	BBCL4834.5
BBCL4234.5	

Base Options Key: FT = Flush Toe LTP = Loose Toe Platform STN = Square Toe Notch MCC = Matching Case Color NHH = No Hinge Holes
 NSH = No Shelf Holes NDSH = No Drawer Slide Holes OS = Omit Shelving

Design Notes:

Standard edgeband color matches cabinet interior color (Coastal White, Fog Grey or White Birch). If eligible, edgeband that matches doors/drawer fronts must be specified. Upcharge applies. Use fillers when installing cabinets adjacent to walls and other cabinets to ensure adequate clearance for doors and drawers. Conestoga recommends that exposed ends be capped with 19mm thick applied decorative end panels (optional and must be specified). When this treatment is used, adjust cabinet width(s) accordingly.

BFDBCR/CSBFDBCR – Base Full Door Blind Cabinet Blind Right

Custom Size Ranges
 Width: 36" – 48"
 Height: 31-1/2" – 42"
 Depth: 12" – 30"
 Functional opening: 12" – 24"

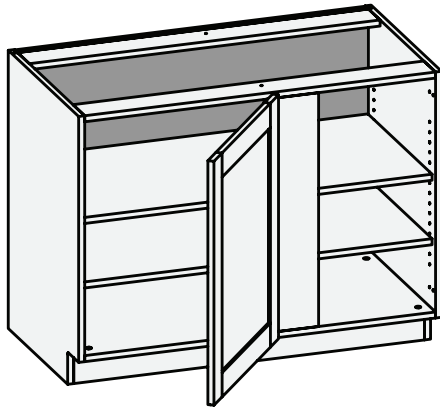

6-1/2" Wide Upright

- Overall cabinet size is the actual width specified.
- Blind section is on the right.
- Specify functional opening width between 12" and 24".
- Door is always hinged on center upright for all overlays.
- Door height and adjacent reveal will follow overlay specified.
- Minimum exposed blind amount for all overlays is 2-1/2" to ensure adequate clearance for adjacent door and drawer function.
- Excessive hardware projection may require a greater amount of exposed blind. Design and install accordingly.
- Specify single or butt door when functional opening is 22-1/2".

24" Deep	
BFDBCR3634.5	BFDBCR4534.5
BFDBCR3934.5	BFDBCR4834.5
BFDBCR4234.5	

BFDBCL/CSBFDBCL – Base Full Door Blind Cabinet Blind Left

Custom Size Ranges
 Width: 36" – 48"
 Height: 31-1/2" – 42"
 Depth: 12" – 30"
 Functional opening: 12" – 24"

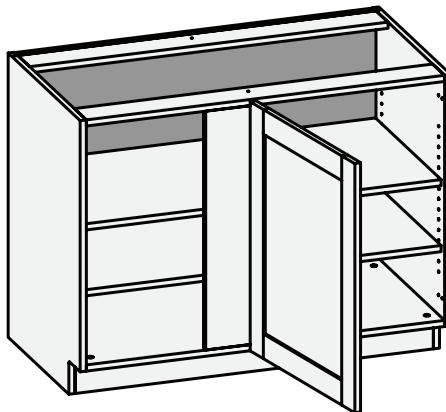

6-1/2" Wide Upright

- Overall cabinet size is the actual width specified.
- Blind section is on the left.
- Specify functional opening width between 12" and 24".
- Door is always hinged on center upright for all overlays.
- Door height and adjacent reveal will follow overlay specified.
- Minimum exposed blind amount for all overlays is 2-1/2" to ensure adequate clearance for adjacent door and drawer function.
- Excessive hardware projection may require a greater amount of exposed blind. Design and install accordingly.
- Specify single or butt door when functional opening is 22-1/2".

24" Deep	
BFDBCL3634.5	BFDBCL4534.5
BFDBCL3934.5	BFDBCL4834.5
BFDBCL4234.5	

Base Options Key: FT = Flush Toe LTP = Loose Toe Platform STN = Square Toe Notch MCC = Matching Case Color NHH = No Hinge Holes
 NSH = No Shelf Holes NDSH = No Drawer Slide Holes OS = Omit Shelving

Design Notes:

Standard edgeband color matches cabinet interior color (Coastal White, Fog Grey or White Birch). If eligible, edgeband that matches doors/drawer fronts must be specified. Upcharge applies. Use fillers when installing cabinets adjacent to walls and other cabinets to ensure adequate clearance for doors and drawers. Conestoga recommends that exposed ends be capped with 19mm thick applied decorative end panels (optional and must be specified). When this treatment is used, adjust cabinet width(s) accordingly.

CSBCT2D – Base Cook Top Two Drawer

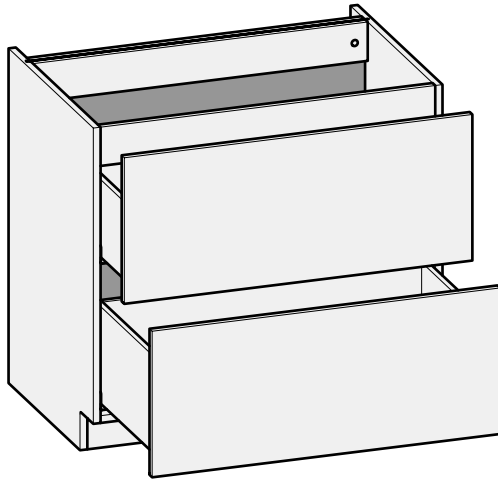

Custom Size Ranges
 Width: 36" – 48"
 Height: 27" - 34-1/2"
 Depth: 24", 27", 30"

- Designed for countertop mounted professional-style cooktops (non-down draft ventilation units).
- Cabinet back recessed 3" to accommodate and conceal supply lines. Drawer box depth is 3" less due to the recessed back.
- Drawer front heights are equal.
- On cabinets less than 31-1/2" in height the top drawer box is 6" high to accommodate appliance housing. Bottom drawer box is 8" high.
- On cabinets equal to or greater than 31-1/2" in height the top drawer box is 8" high to accommodate appliance housing. Bottom drawer box is 10" high.

BR3D/CSBR3D – Base Range Three Drawer

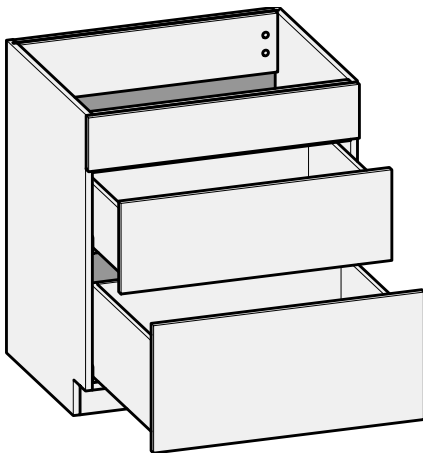

Custom Size Ranges
 Width: 30" – 39"
 Height: 31-1/2" – 34-1/2"
 Depth: 12", 13", 15", 16",
 18", 21", 24", 27",
 30"

- False top drawer front.
- When height changes, lower opening height changes. Upper and middle drawer front heights fixed at 5-15/16" and 10".

24" Deep	
BR3D3034.5	BR3D3634.5

Base Options Key: FT = Flush Toe LTP = Loose Toe Platform STN = Square Toe Notch MCC = Matching Case Color NHH = No Hinge Holes
 NSH = No Shelf Holes NDSH = No Drawer Slide Holes OS = Omit Shelving

Design Notes:

Standard edgeband color matches cabinet interior color (Coastal White, Fog Grey or White Birch). If eligible, edgeband that matches doors/drawer fronts must be specified. Upcharge applies. Use fillers when installing cabinets adjacent to walls and other cabinets to ensure adequate clearance for doors and drawers. Conestoga recommends that exposed ends be capped with 19mm thick applied decorative end panels (optional and must be specified). When this treatment is used, adjust cabinet width(s) accordingly.

BRT2D/CSBRT2D - Base Range Top Two Drawer

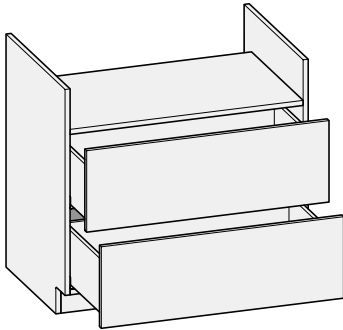

Custom Size Ranges
 Width: 36" – 48"
 Height: 34-1/2"
 Depth: 24", 27", 30"

- Designed for professional-style cooktop units.
- 6" high standard opening includes full floor to support appliance. Opening height is customizable from 5" to 8" in 1/16" increments.
- Cabinet back recessed 3" to accommodate and conceal supply lines. Drawer box depth is 3" less due to the recessed back.
- Both drawer boxes are 8" high.

24" Deep	
BRT2D3634.5	BRT2D4534.5
BRT2D3934.5	BRT2D4834.5
BRT2D4234.5	

BUCM/CSBUCM - Base Under Counter Microwave

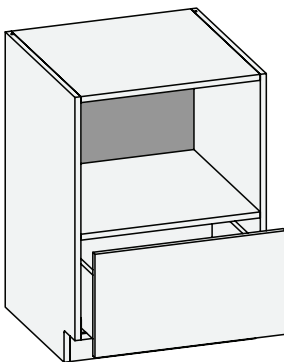

Custom Size Ranges
 Width: 24" – 36"
 Height: 24" - 42"
 Depth: 12", 13", 15", 16", 18",
 21", 23", 27", 30"

- For 34-1/2" high cabinets, top opening height is 16-1/2".
- When height changes, upper opening height changes. Lower drawer front height fixed at 13".

24" Deep	
BUCM2434.5	
BUCM2734.5	
BUCM3034.5	

BIUCM/CSBIUCM – Built In Under Counter Microwave

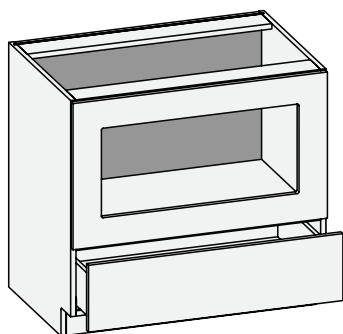

Custom Size Ranges
 Width: 24" – 36"
 Height: 24" - 42"
 Depth: 12", 13", 15", 16", 18",
 21", 23", 27", 30"

- Customer to specify height and width of Microwave opening in trim panel.
- For 34-1/2" high cabinets, top opening height is 19-3/4".
- Maximum Microwave opening height is top opening minus 5".
- Maximum Microwave opening width is cabinet width minus 6".
- When height changes, upper opening height changes. Lower drawer front height fixed at 9-1/2".

24" Deep	
BIUCM2734.5	BIUCM3334.5
BIUCM3034.5	BIUCM3634.5

Base Options Key: FT = Flush Toe LTP = Loose Toe Platform STN = Square Toe Notch MCC = Matching Case Color NHH = No Hinge Holes
 NSH = No Shelf Holes NDSH = No Drawer Slide Holes OS = Omit Shelving

Design Notes:

Standard edgeband color matches cabinet interior color (Coastal White, Fog Grey or White Birch). If eligible, edgeband that matches doors/drawer fronts must be specified. Upcharge applies. Use fillers when installing cabinets adjacent to walls and other cabinets to ensure adequate clearance for doors and drawers. Conestoga recommends that exposed ends be capped with 19mm thick applied decorative end panels (optional and must be specified). When this treatment is used, adjust cabinet width(s) accordingly.

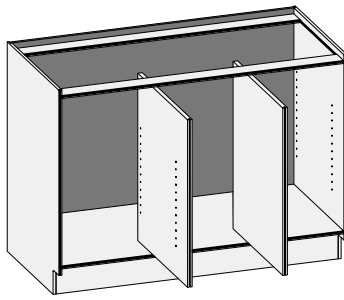
CSBCO - Base Case Only Cabinet

 Partition D
 (Right)

 Partition C
 (Left)

Custom Size Ranges
 Width: 9" – 96"
 Height: 8" – 48"
 Depth: 8" – 30"

- Customizable cabinet case for custom base applications.
- Sides are machined with shelf holes.
- Optional partitions are sized to fit between top stringers and bottom of cabinet. Self-tapping screws are provided to secure partition into place. Specify quantity of each style partition required.
 - Partition A has no shelf holes.
 - Partition B has thru holes.
 - Partition C has shelf holes on the left side. (Pairs with the right cabinet side).
 - Partition D has shelf holes on the right side. (Pairs with the Left cabinet side).
- Specify shelf quantity per cabinet and length of each shelf. Up to 4 different shelf lengths can be specified. Shelf depth is calculated automatically by the system.
- Order partial overlay hinge kit #2103705 when mounting doors on a partition.

Vesta Tall Cabinet Standard Features and Options:

The features below are standard on all Tall cabinets where the design permits. Standard features can be omitted as needed. The option to omit standard features as well as add additional design options can be quickly referenced at the bottom of each page in the Tall Cabinet Section labeled “Tall Options Key”. For detailed descriptions and images of the options, see Options, Section 20 of this manual. Standard features and options are available on all Tall cabinets unless specifically noted as **Unavailable Options**.

Edgeband – On our Tall cabinets the sides, tops, bottoms, mid-floors, and shelves are edgebanded on the front edges only. Interior parts such as uprights or other support members are edgebanded on visible edges. Edgeband color must be specified to either match the case color (standard offering) or door color if applicable (upcharge applies). When Door Matching Edgeband Option is selected the front edges of the sides, tops, bottoms and mid-floors are edgebanded using the door color. The edgeband on the shelves and interior parts matches the interior case color. Door Matching Edgeband Option is available with all Allure DLV, Intrigue TTS, Strata TTS, Vogue TTS, Synchronicity High Gloss and Super Matte colors, as well as matching specie wood edgeband in Cherry, Hard Maple, Paint Grade, Red Oak, Rift Cut White Oak and Walnut.

5mm Shelf Holes – 5mm Shelf Holes are pre-drilled on 32mm centers on all cabinets with shelves. **No Shelf Holes (NSH)** and **Omit Shelving (OS)** Options are available on any Tall cabinet with shelves. If both the NSH and OS Options are required, both must be individually specified.

Hinge Hole Drilling – All Tall cabinets eligible to receive doors will include Blum Frameless INSERTA Hinges and are pre-drilled with 5mm holes to accept the EXPANDO Mounting Plates. A **No Hinge Hole (NHH)** Option is available on Tall cabinets that would typically include doors. Cabinet hinges can also be omitted, but must be changed from the default Yes to No. The No Hinge Hole Option does not remove hinges; No Hinges must be specified.

Drawer Slide Hole Drilling – All Tall cabinets that include drawer boxes also include Blum TANDEM Drawer Slides and are pre-drilled with 5mm holes for quick and easy installation. The **No Drawer Slide Hole (NDSH)** Option is available only on cabinets with drawer boxes. Drawer slides can be omitted, but must be changed from the default Yes to No. The No Drawer Slide Hole Option does not automatically remove drawer slides; No Drawer Slides must be specified.

Toe Kick – Most Tall cabinets come with a 3-3/4” x 4” Toe Kick Notch standard. Cabinets with a Toe Kick are available with either the **Flush Toe (FT)** and **Square Toe Notch (STN)** Options. The Flush Toe Option removes the toe kick from the cabinet and brings the toe backer flush with the cabinet front edge. The Square Toe Notch Option makes the intersecting corner of the Toe Notch 90° to aid in Toeboard installation.

Matching Case Color (MCC) – With the Matching Case Color Option, the door and drawer front color matches the cabinet interior, exterior and edgeband. The Matching Case Color Option is available with most Tall cabinets and produced in all Intrigue TTS, Strata TTS and Vogue TTS colors, as well as wood matching specie edgeband in Cherry, Hard Maple, Paint Grade, Red Oak, Rift Cut White Oak and Walnut.

Loose Toe Platform (LTP) – With the Loose Toe Platform Option, the cabinet height is automatically reduced by 4” and is produced without a Toe Kick. A 4” platform is provided to achieve the desired finished cabinet height. When ordering the Loose Toe Platform Option enter the desired cabinet height, deductions for the toe platform are calculated by Conestoga. Loose Toe Platform is available with most Tall cabinets. The Flush Toe and Square Toe Notch Options are not available with the Loose Toe Platform Option.

Tall Options Key: FT = Flush Toe LTP = Loose Toe Platform STN = Square Toe Notch MCC = Matching Color Case NHH = No Hinge Holes
NSH = No Shelf Holes NDSH = No Drawer Slide Holes OS = Omit Shelving

Design Notes:

Standard edgeband color matches cabinet interior color (Coastal White, Fog Grey or White Birch). If eligible, edgeband that matches doors/drawer fronts must be specified. Upcharge applies. Use fillers when installing cabinets adjacent to walls and other cabinets to ensure adequate clearance for doors and drawers. Conestoga recommends that exposed ends be capped with 19mm thick applied decorative end panels (optional and must be specified). When this treatment is used, adjust cabinet width(s) accordingly.

UCD/CSUC - Utility Cabinet

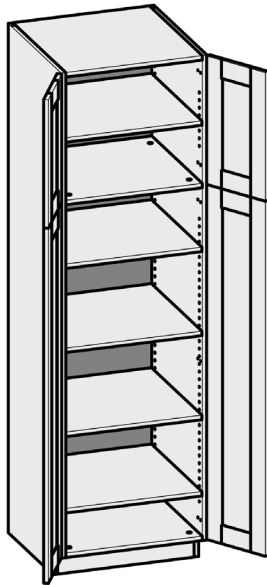

Custom Size Ranges
 Single Door Width: 12" – 24"
 Butt Door Width: 24" – 36"
 Height: 84" – 96"
 Depth: 8" – 30"

- When height changes, upper opening height changes. Lower opening height fixed at 57-1/2".
- 84" – 90" high has six shelves.
- 90-1/16" – 96" high has seven shelves.
- Separate 4" high toe platform available in all cabinet heights.
- Specify single or butt doors on custom size cabinets 24" wide.

Single Door Cabinets – 24" Deep			Butt Door Cabinets – 24" Deep		
84" High	90" High	96" High	84" High	90" High	96" High
UCD1584	UCD1590	UCD1596	UCD2484BD	UCD2490BD	UCD2496BD
UCD1884	UCD1890	UCD1896	UCD2784BD	UCD2790BD	UCD2796BD
UCD2184	UCD2190	UCD2196	UCD3084BD	UCD3090BD	UCD3096BD
UCD2484	UCD2490	UCD2496	UCD3384BD	UCD3390BD	UCD3396BD
			UCD3684BD	UCD3690BD	UCD3696BD

UCDW/CSUCW - Utility Cabinet Wall Height Top Section

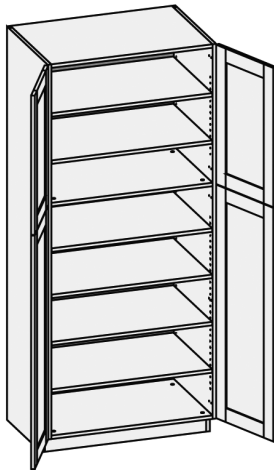

Custom Size Ranges
 Single Door Width:
 12" – 24"
 Butt Door Width:
 24" – 36"
 Height: 84" – 96"
 Depth: 8" – 30"

- Top section aligns with corresponding wall cabinet height as follows:
 84" high – 30" wall cabinets.
 90" high – 36" wall cabinets.
 96" high – 42" wall cabinets.
- When cabinet height changes, top opening height changes accordingly. Opening height below mid-floor is fixed at 49".
- 84" – 90" high has six shelves.
- 90-1/16" – 96" high has seven shelves.
- Separate 4" high toe platform available in all cabinet heights.
- Specify single or butt doors on custom size cabinets 24" wide.

Single Door Cabinets – 24" Deep			Butt Door Cabinets – 24" Deep		
84" High	90" High	96" High	84" High	90" High	96" High
UCDW1584	UCDW1590	UCDW1596	UCDW2484BD	UCDW2490BD	UCDW2496BD
UCDW1884	UCDW1890	UCDW1896	UCDW2784BD	UCDW2790BD	UCDW2796BD
UCDW2184	UCDW2190	UCDW2196	UCDW3084BD	UCDW3090BD	UCDW3096BD
UCDW2484	UCDW2490	UCDW2496	UCDW3384BD	UCDW3390BD	UCDW3396BD
			UCDW3684BD	UCDW3690BD	UCDW3696BD

Tall Options Key: FT = Flush Toe LTP = Loose Toe Platform STN = Square Toe Notch MCC = Matching Color Case NHH = No Hinge Holes
 NSH = No Shelf Holes NDSH = No Drawer Slide Holes OS = Omit Shelving

Design Notes:

Standard edgeband color matches cabinet interior color (Coastal White, Fog Grey or White Birch). If eligible, edgeband that matches doors/drawer fronts must be specified. Upcharge applies. Use fillers when installing cabinets adjacent to walls and other cabinets to ensure adequate clearance for doors and drawers. Conestoga recommends that exposed ends be capped with 19mm thick applied decorative end panels (optional and must be specified). When this treatment is used, adjust cabinet width(s) accordingly.

UCDR/CSUCR - Utility Cabinet Reverse w/Butt Doors

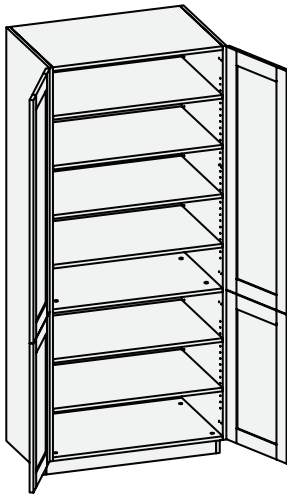

Custom Size Ranges
 Single Door Width:
 12" – 24"
 Butt Door Width:
 24" – 36"
 Height: 84" – 96"
 Depth: 8" – 30"

- When cabinet height changes, upper opening height changes. Opening height below mid-floor fixed at 29-5/16".
- 84" – 90" high has six shelves.
- 90-1/16" – 96" high has seven shelves.
- Separate 4" high toe platform available in all cabinet heights.
- Specify single or butt doors on custom size cabinets 24" wide.

Single Door Cabinets – 24" Deep			Butt Door Cabinets – 24" Deep		
84" High	90" High	96" High	84" High	90" High	96" High
UCDR1584	UCDR1590	UCDR1596	UCDR2484BD	UCDR2490BD	UCDR2496BD
UCDR1884	UCDR1890	UCDR1896	UCDR2784BD	UCDR2790BD	UCDR2796BD
UCDR2184	UCDR2190	UCDR2196	UCDR3084BD	UCDR3090BD	UCDR3096BD
UCDR2484	UCDR2490	UCDR2496	UCDR3384BD	UCDR3390BD	UCDR3396BD
			UCDR3684BD	UCDR3690BD	UCDR3696BD

Tall Options Key: FT = Flush Toe LTP = Loose Toe Platform STN = Square Toe Notch MCC = Matching Color Case NHH = No Hinge Holes
 NSH = No Shelf Holes NDSH = No Drawer Slide Holes OS = Omit Shelving

Design Notes:

Standard edgeband color matches cabinet interior color (Coastal White, Fog Grey or White Birch). If eligible, edgeband that matches doors/drawer fronts must be specified. Upcharge applies. Use fillers when installing cabinets adjacent to walls and other cabinets to ensure adequate clearance for doors and drawers. Conestoga recommends that exposed ends be capped with 19mm thick applied decorative end panels (optional and must be specified). When this treatment is used, adjust cabinet width(s) accordingly.

U2D/CSU2D - Utility Two Drawer

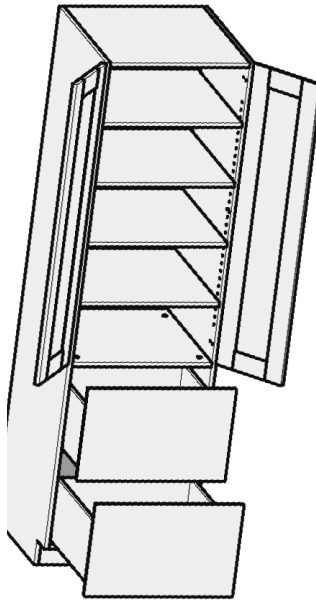

Custom Size Ranges
 Single Door Width:
 12" – 24"
 Butt Door Width:
 24" – 36"
 Height: 84" – 96"
 Depth: 12", 13", 15",
 16", 18", 21",
 24", 27", 30"

- When height changes, upper opening height changes.
- Lower drawer section aligns with 34-1/2" high Base cabinets. Drawer front heights are equal.
- 84" – 90" high has four shelves.
- 90-1/16" – 96" high has five shelves.
- Specify single or butt doors on custom size cabinets 24" wide.

Single Door Cabinets – 24" Deep		
84" High	90" High	96" High
U2D1884	U2D1890	U2D1896
U2D2184	U2D2190	U2D2196
U2D2484	U2D2490	U2D2496
Butt Door Cabinets – 24" Deep		
84" High	90" High	96" High
U2D2484BD	U2D2490BD	U2D2496BD
U2D2784BD	U2D2790BD	U2D2796BD
U2D3084BD	U2D3090BD	U2D3096BD
U2D3384BD	U2D3390BD	U2D3396BD
U2D3684BD	U2D3690BD	U2D3696BD

Tall Options Key: FT = Flush Toe LTP = Loose Toe Platform STN = Square Toe Notch MCC = Matching Color Case NHH = No Hinge Holes
 NSH = No Shelf Holes NDSH = No Drawer Slide Holes OS = Omit Shelving

Design Notes:

Standard edgeband color matches cabinet interior color (Coastal White, Fog Grey or White Birch). If eligible, edgeband that matches doors/drawer fronts must be specified. Upcharge applies. Use fillers when installing cabinets adjacent to walls and other cabinets to ensure adequate clearance for doors and drawers. Conestoga recommends that exposed ends be capped with 19mm thick applied decorative end panels (optional and must be specified). When this treatment is used, adjust cabinet width(s) accordingly.

U3D/CSU3D - Utility Three Drawer

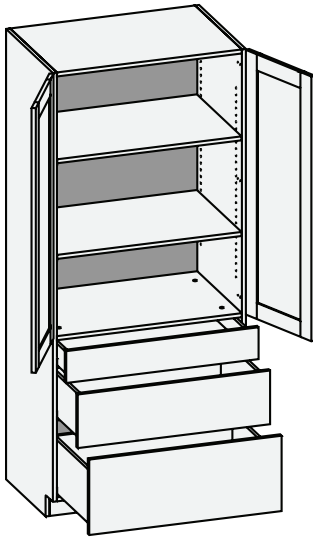

Custom Size Ranges
 Single Door Width:
 12" – 24"
 Butt Door Width:
 24" – 36"
 Height: 84" – 96"
 Depth: 12", 13", 15",
 16", 18", 21",
 24", 27", 30"

- When height changes, upper opening height changes.
- Lower drawer section aligns with 34-1/2" high Base cabinets. Drawer front heights fixed at 5-15/16", 10" and 14-1/16".
- 84" – 90" high has four shelves.
- 90-1/16" – 96" high has five shelves.
- Specify single or butt doors on custom size cabinets 24" wide.

Single Door Cabinets – 24" Deep			Butt Door Cabinets – 24" Deep		
84" High	90" High	96" High	84" High	90" High	96" High
U3D1884	U3D1890	U3D1896	U3D2484BD	U3D2490BD	U3D2496BD
U3D2184	U3D2190	U3D2196	U3D2784BD	U3D2790BD	U3D2796BD
U3D2484	U3D2490	U3D2496	U3D3084BD	U3D3090BD	U3D3096BD
			U3D3384BD	U3D3390BD	U3D3396BD
			U3D3684BD	U3D3690BD	U3D3696BD

U3DEH/CSU3DEH - Utility Three Drawer w/Two Equal Height Lower Drawers

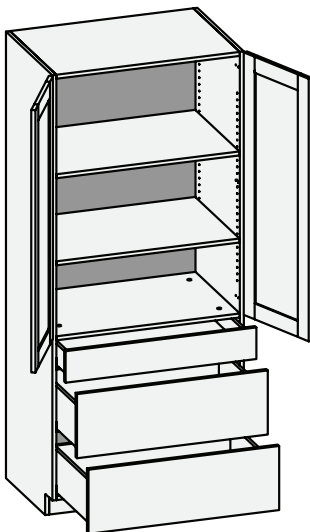

Custom Size Ranges
 Single Door Width:
 12" – 24"
 Butt Door Width:
 24" – 36"
 Height: 84" – 96"
 Depth: 12", 13", 15",
 16", 18", 21",
 24", 27", 30"

- When height changes, upper opening height changes.
- Lower drawer section aligns with 34-1/2" high Base cabinets. Drawer front heights fixed at 5-15/16", 12" and 12-1/16".
- 84" – 90" high has four shelves.
- 90-1/16" – 96" high has five shelves.
- Specify single or butt doors on custom size cabinets 24" wide.

Single Door Cabinets – 24" Deep		
84" High	90" High	96" High
U3DEH1884	U3DEH1890	U3DEH1896
U3DEH2184	U3DEH2190	U3DEH2196
U3DEH2484	U3DEH2490	U3DEH2496
Butt Door Cabinets – 24" Deep		
84" High	90" High	96" High
U3DEH2484BD	U3DEH2490BD	U3DEH2496BD
U3DEH2784BD	U3DEH2790BD	U3DEH2796BD
U3DEH3084BD	U3DEH3090BD	U3DEH3096BD
U3DEH3384BD	U3DEH3390BD	U3DEH3396BD
U3DEH3684BD	U3DEH3690BD	U3DEH3696BD

Tall Options Key: FT = Flush Toe LTP = Loose Toe Platform STN = Square Toe Notch MCC = Matching Color Case NHH = No Hinge Holes
 NSH = No Shelf Holes NDSH = No Drawer Slide Holes OS = Omit Shelving

Design Notes:

Standard edgeband color matches cabinet interior color (Coastal White, Fog Grey or White Birch). If eligible, edgeband that matches doors/drawer fronts must be specified. Upcharge applies. Use fillers when installing cabinets adjacent to walls and other cabinets to ensure adequate clearance for doors and drawers. Conestoga recommends that exposed ends be capped with 19mm thick applied decorative end panels (optional and must be specified). When this treatment is used, adjust cabinet width(s) accordingly.

ODA/CSODA - Oven Double Opening Type A w/Butt Doors

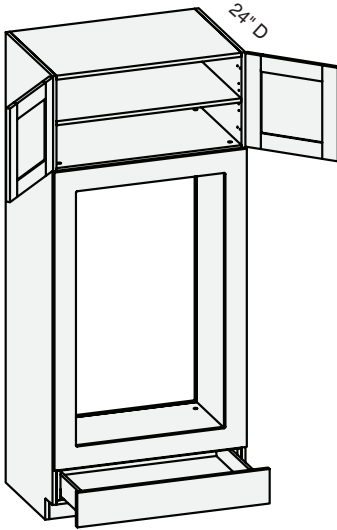

Custom Size Ranges
 Width: 27" – 36"
 Height: 84" – 96"
 Depth: 24", 27", 30"

- Customer to specify height and width of oven opening.
- Maximum oven opening height is 49-5/8".
- Maximum oven opening width is cabinet width minus 6".
- Oven shelf is 11" above the floor.
- When height changes, upper opening height changes. Lower and middle opening heights are fixed.
- 84" – 95" high has one shelf.
- 95-1/16" – 96" high has two shelves.
- Separate 4" high toe platform available in all cabinet heights.

84" High	90" High	96" High
ODA2784BD	ODA2790BD	ODA2796BD
ODA3084BD	ODA3090BD	ODA3096BD
ODA3384BD	ODA3390BD	ODA3396BD

ODB/CSODB - Oven Double Opening Type B w/Butt Doors

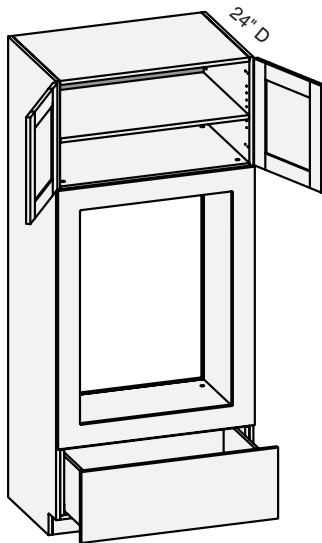

Custom Size Ranges
 Width: 27" – 36"
 Height: 84" – 96"
 Depth: 24", 27", 30"

- Customer to specify height and width of oven opening.
- Maximum oven opening height is 41-1/8".
- Maximum oven opening width is cabinet width minus 6".
- Oven shelf is 17-1/2" above the floor.
- When height changes, upper opening height changes. Lower and middle opening heights are fixed.
- 84" – 95" high has one shelf.
- 95-1/16" – 96" high has two shelves.
- Separate 4" high toe platform available in all cabinet heights.

84" High	90" High	96" High
ODB3084BD	ODB3090BD	ODB3096BD
ODB3384BD	ODB3390BD	ODB3396BD

Tall Options Key: FT = Flush Toe LTP = Loose Toe Platform STN = Square Toe Notch MCC = Matching Color Case NHH = No Hinge Holes
 NSH = No Shelf Holes NDSH = No Drawer Slide Holes OS = Omit Shelving

Design Notes:

Standard edgeband color matches cabinet interior color (Coastal White, Fog Grey or White Birch). If eligible, edgeband that matches doors/drawer fronts must be specified. Upcharge applies. Use fillers when installing cabinets adjacent to walls and other cabinets to ensure adequate clearance for doors and drawers. Conestoga recommends that exposed ends be capped with 19mm thick applied decorative end panels (optional and must be specified). When this treatment is used, adjust cabinet width(s) accordingly.

CSOS - Oven Single Opening w/Butt Doors

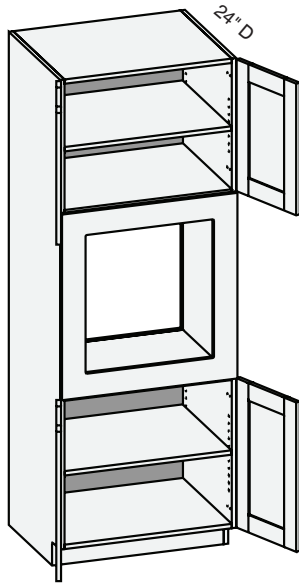

Custom Size Ranges
 Width: 27" – 36"
 Height: 84" – 96"
 Depth: 24" – 30"

- Customer to specify height and width of oven opening.
- Maximum oven opening height is 25-5/8".
- Maximum oven opening width is cabinet width minus 6".
- Oven shelf is fixed at 30" above the floor.
- When height changes, upper opening height changes. Lower and middle opening heights are fixed.
- Lower opening is fixed at 24-5/8".
- 84" – 89" high has two shelves.
- 89-1/16" – 95" high has three shelves.
- 95-1/6" – 96" high has four shelves.
- Separate 4" high toe platform available in all cabinet heights.

CSRTEPC - Refrigerator Tall End Panel Cabinet w/ Butt Doors

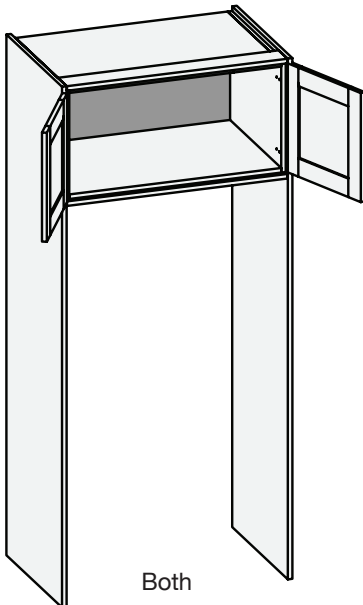

Custom Size Ranges
 Width: 24" – 42"
 Height: 84" – 96"
 Depth: 24" – 30"

- CSRTEPC is a preconfigured Tall cabinet designed to enclose a refrigerator with decorative end panels.
- When ordering CSRTEPC specify the desired cabinet width, overall height, depth, and top cabinet height without end panels. The system will calculate the appropriate end panels to give doors an inset appearance.
- Assembled unit with end panels attached will be 1-1/2" wider, 3/4" taller, and 7/8" deeper than the size ordered. Top cabinet height will be 1-1/2" taller than size ordered.
- Specify Left, Right, or Both for the panel leg extension.
- 18-1/16" – 24" high upper cabinet has one shelf.
- 24-1/16" – 27" high upper cabinet has two shelves.
- Specify single or butt doors on custom size cabinets 24" wide.
- Unavailable Options: FT, LTP, STN.

Tall Options Key: FT = Flush Toe LTP = Loose Toe Platform STN = Square Toe Notch MCC = Matching Color Case NHH = No Hinge Holes
 NSH = No Shelf Holes NDSH = No Drawer Slide Holes OS = Omit Shelving

Design Notes:

Standard edgeband color matches cabinet interior color (Coastal White, Fog Grey or White Birch). If eligible, edgeband that matches doors/drawer fronts must be specified. Upcharge applies. Use fillers when installing cabinets adjacent to walls and other cabinets to ensure adequate clearance for doors and drawers. Conestoga recommends that exposed ends be capped with 19mm thick applied decorative end panels (optional and must be specified). When this treatment is used, adjust cabinet width(s) accordingly.

CSRTB (L&R) Refrigerator Tall Cabinet - Both, Left, & Right

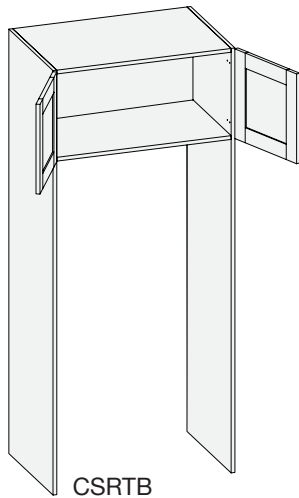

Custom Size Ranges
 Width: 9" – 42"
 Height: 84" – 96"
 Depth: 8" – 30"

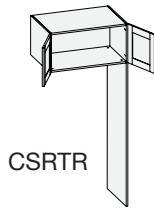
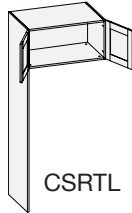

- When ordering custom size refrigerator cabinets specify top cabinet height.
- 7" – 18" high upper cabinet has no shelves.
- 18-1/16" – 24" high upper cabinet has one shelf.
- 24-1/16" – 36" high upper cabinet has two shelves.
- 36-1/16" – 48" high upper cabinet has three shelves.
- 48-1/16" – 60" high upper cabinet has four shelves.
- 60-1/16" – 72" high upper cabinet has five shelves.
- Not recommended for end panels applications. For end panel application use CSRTEPC cabinet.
- Unavailable options: FT, LTP, STN.

CSRTBHKXS (L&R) Refrigerator Tall Cabinet - Both, Left, & Right

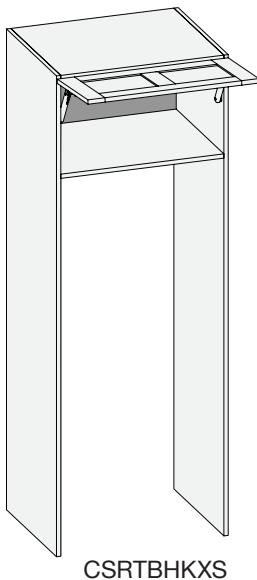

Custom Size Ranges
 Width: 9" – 42"
 Height: 84" – 96"
 Depth: 8" – 30"
 Top Cab Height: 7" - 24"

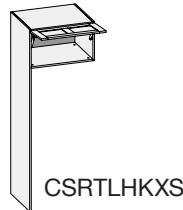

- Preconfigured units include HK-XS Series lift system hardware and Blum COMPACT hinges.
- Door weight and design determine the strength and quantity of lift mechanisms provided.
- Cabinet width 15" – 24" are single panel door designs. 24-1/16" – 36" are two panels side by side. Upcharges for 2 panel door applies.
- When ordering custom size refrigerator cabinets specify top cabinet height.
- 7" – 18" high upper cabinet has no shelves.
- 18-1/16" – 24" high upper cabinet has one shelf.
- Not recommended for end panels applications. For end panel application use CSWHKXS cabinet with custom end panels.
- Unavailable options: FT, LTP, STN.

Tall Options Key: FT = Flush Toe LTP = Loose Toe Platform STN = Square Toe Notch MCC = Matching Color Case NHH = No Hinge Holes
 NSH = No Shelf Holes NDSH = No Drawer Slide Holes OS = Omit Shelving

Design Notes:

Standard edgeband color matches cabinet interior color (Coastal White, Fog Grey or White Birch). If eligible, edgeband that matches doors/drawer fronts must be specified. Upcharge applies. Use fillers when installing cabinets adjacent to walls and other cabinets to ensure adequate clearance for doors and drawers. Conestoga recommends that exposed ends be capped with 19mm thick applied decorative end panels (optional and must be specified). When this treatment is used, adjust cabinet width(s) accordingly.

CSCO - Case Only

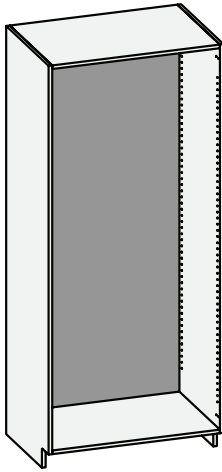

Custom Size Ranges
Width: 12" – 36"
Height: 10" – 96"
Depth: 8" – 30"



Shelf



Loose fixed floor kit

- Customizable cabinet case for custom base and tall applications.
- Sides are machined with shelf holes.
- Loose Fixed Floor Kits are sized to fit between sides. Specify quantity of Loose Fixed Floor Kits per cabinet.
- Specify quantity of shelves per cabinet.

Tall Options Key: FT = Flush Toe LTP = Loose Toe Platform STN = Square Toe Notch MCC = Matching Color Case NHH = No Hinge Holes
NSH = No Shelf Holes NDSH = No Drawer Slide Holes OS = Omit Shelving

Design Notes:

Standard edgeband color matches cabinet interior color (Coastal White, Fog Grey or White Birch). If eligible, edgeband that matches doors/drawer fronts must be specified. Upcharge applies. Use fillers when installing cabinets adjacent to walls and other cabinets to ensure adequate clearance for doors and drawers. Conestoga recommends that exposed ends be capped with 19mm thick applied decorative end panels (optional and must be specified). When this treatment is used, adjust cabinet width(s) accordingly.

Vesta Vanity Cabinet Standard Features and Options

The features below are standard on all Vanity cabinets where the design permits. Standard features can be omitted as needed. The option to omit standard features as well as add design options can be quickly referenced at the bottom of each page in the Vanity Cabinet Section labeled “Vanity Options Key”. For detailed descriptions and images of the options, see Options, Section 20 of this manual. Standard features and options are available on all Vanity cabinets unless specifically noted as **Unavailable Options**.

Edgeband – Our Vanity cabinets sides, tops, bottoms, mid-floors and shelves are edgebanded on front edge only. Interior parts such as uprights or other support members are edgebanded on visible edges. Edgeband color must be specified to either match the case color (standard offering) or door color if applicable (upcharge applies). When Door Matching Edgeband Option is selected the front edges of the sides, top, bottom and mid-floor are edgebanded using the door color. The edgeband on the shelves and interior parts matches the interior case color. Door Matching Edgeband Option available with all Allure DLV, Intrigue TTS, Strata TTS, Vogue TTS, Synchronicity High Gloss and Super Matte colors as well as wood edgeband in Cherry, Hard Maple, Paint Grade, Red Oak, Rift Cut White Oak and Walnut.

5mm Shelf Holes – 5mm shelf holes are pre-drilled on 32mm centers on all cabinets with shelves. **No Shelf Holes** (NSH) and **Omit Shelving** (OS) Options are available on any vanity cabinet with shelves. If both the NSH and OS Options are required, both must be individually specified.

Hinge Hole Drilling – All Vanity cabinets eligible to receive doors will include Blum Frameless INSERTA Hinges and are pre-drilled with 5mm holes to accept the EXPANDO Mounting Plates. A **No Hinge Hole** (NHH) Option is available on Vanity cabinets that would typically include doors. Cabinet hinges can also be omitted, but must be changed from the default Yes to No. The No Hinge Hole Option does not remove hinges; No Hinges must be specified.

Drawer Slide Hole Drilling – All Vanity cabinets that include drawer boxes also include Blum TANDEM Drawer Slides and are pre-drilled with 5mm holes for quick and easy installation. The **No Drawer Slide Hole** (NDSH) Option is available only on cabinets with drawer boxes. Drawer slides can be omitted, but must be changed from the default Yes to No. The No Shelf Holes Option does not automatically remove drawer slides; No Drawer Slides must be specified.

Toe Kick – Most Vanity Base and Vanity Tall cabinets come with a 3-3/4” x 4” Toe Kick Notch standard. Cabinets with a Toe Kick are available with either the **Flush Toe** (FT) and **Square Toe Notch** (STN) Options. The Flush Toe Option removes the toe kick from the cabinet and brings the toe backer flush with the cabinet front edge. The Square Toe Notch Option makes the intersecting corner of the toe notch 90° to aid in toeboard installation.

Matching Case Color (MCC) – With the Matching Case Color Option, the door and drawer front color matches the cabinet interior, exterior and edgeband. The Matching Case Color Option is available with most Vanity cabinets and produced in all Intrigue TTS, Strata TTS and Vogue TTS colors.

Loose Toe Platform (LTP) – With the Loose Toe Platform Option, the cabinet height is automatically reduced by 4” and is produced without a toe kick. A 4” platform is provided to achieve the desired finished cabinet height. When ordering Loose Toe Platform enter the desired cabinet height, deductions for the toe platform are calculated by Conestoga. Loose Toe Platform is available with most Vanity cabinets. The Flush Toe and Square Toe Notch Options are not available with Loose Toe Platform.

Vanity Options Key: FT = Flush Toe LTP = Loose Toe Platform STN = Square Toe Notch MCC = Matching Case Color NHH = No Hinge Holes
NSH = No Shelf Holes NDSH = No Drawer Slide Holes

Design Notes:

Standard edgeband color matches cabinet interior color (Coastal White, Fog Grey or White Birch). Edgeband that matches doors/drawer fronts is available and must be specified. Upcharge applies. Use fillers when installing cabinets adjacent to walls and other cabinets to ensure adequate clearance for doors and drawers. Conestoga recommends that exposed ends be capped with 19mm thick applied decorative end panels (optional and must be specified). When this treatment is used, adjust cabinet width(s) accordingly.

VB/CSB - Vanity Base

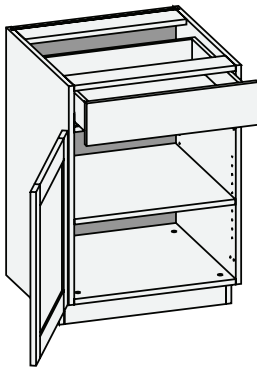

Custom Size Ranges
 Width: 12" – 24"
 Height: 31-1/2" – 42"
 Depth: 12", 13", 15", 16",
 18", 21", 24", 27",
 30"

- When height changes, lower opening height changes.
- Upper opening height fixed at 5".
- Specify single or butt doors on custom size cabinets 24" wide.

21" Deep	
31-1/2" High	34-1/2" High
VB1231.5	VB1234.5
VB1531.5	VB1534.5
VB1831.5	VB1834.5
VB2131.5	VB2134.5

VS/CSBS - Vanity Sink w/Butt Doors

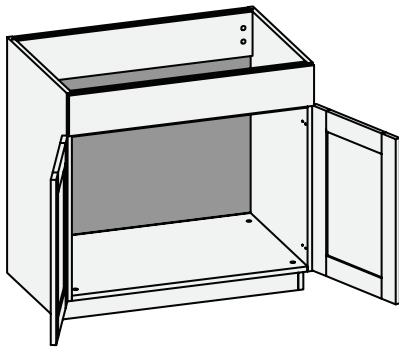

Custom Size Ranges
 Width: 24" – 36"
 Height: 31-1/2" – 42"
 Depth: 18" – 30"

- False drawer front.
- No drawer box, shelf support holes or shelf with sink units.
- When height changes, lower opening height changes.
- Upper drawer front height fixed at 5-15/16".
- Specify single or butt doors on custom size cabinets 24" wide.

21" Deep	
31-1/2" High	34-1/2" High
VS2431.5BD	VS2434.5BD
VS2731.5BD	VS2734.5BD
VS3031.5BD	VS3034.5BD
VS3331.5BD	VS3334.5BD
VS3631.5BD	VS3634.5BD

VSRV/CSVSRV - Vanity Sink Reverse w / Butt Doors

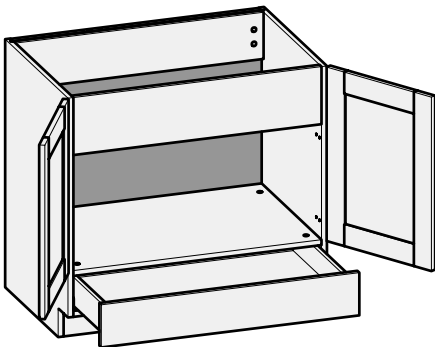

Custom Size Ranges
 Width: 24" – 36"
 Height: 31-1/2" – 42"
 Depth: 12", 13", 15", 16",
 18", 21", 24", 27", 30"

- When height changes, upper opening height changes.
- Lower drawer front height fixed at 5-15/16".

21" Deep	
31-1/2" High	34-1/2" High
VSRV2431.5BD	VSRV2434.5BD
VSRV3031.5BD	VSRV3034.5BD
VSRV3631.5BD	VSRV3634.5BD

Vanity Options Key: FT = Flush Toe LTP = Loose Toe Platform STN = Square Toe Notch MCC = Matching Case Color NHH = No Hinge Holes
 NSH = No Shelf Holes NDSH = No Drawer Slide Holes

Design Notes:

Standard edgeband color matches cabinet interior color (Coastal White, Fog Grey or White Birch). Edgeband that matches doors/drawer fronts is available and must be specified. Upcharge applies. Use fillers when installing cabinets adjacent to walls and other cabinets to ensure adequate clearance for doors and drawers. Conestoga recommends that exposed ends be capped with 19mm thick applied decorative end panels (optional and must be specified). When this treatment is used, adjust cabinet width(s) accordingly.

VPB/CSBFD - Vanity Base Full Door

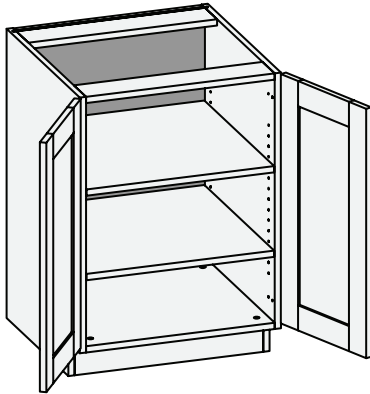

Custom Size Ranges
 Single Door Width: 9" – 24"
 Butt Door Width: 24" – 36"
 Height: 10" – 42"
 Single Door Depth: 12" – 30"
 Butt Door Depth: 12" – 30"

- 10" – 22" high has no shelves.
- 22-1/16" – 28" high has one shelf.
- 28-1/16" – 40" high has two shelves.
- 40-1/16" – 48" high has three shelves.
- Specify single or butt doors on custom size cabinets 24" wide.

Single Door Cabinet – 21" Deep		Butt Door Cabinets – 21" Deep	
31-1/2" High	34-1/2" High	31-1/2" High	34-1/2" High
VBF1831.5	VBF1834.5	VBF2431.5BD	VBF2434.5BD
		VBF2731.5BD	VBF2734.5BD
		VBF3031.5BD	VBF3034.5BD
		VBF3631.5BD	VBF3634.5BD

V3D/CSB3D - Vanity Three Drawer

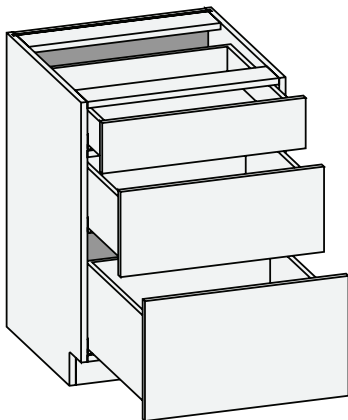

Custom Size Ranges
 Width: 12" – 39"
 Height: 31-1/2" – 34-1/2"
 Depth: 12", 13", 15", 16",
 18", 21", 24", 27",
 30"

- When height changes, lower drawer front height changes.
- Upper and middle drawer front heights fixed at 5-15/16" and 10".

21" Deep	
31-1/2" High	34-1/2" High
V3D1231.5	V3D1234.5
V3D1531.5	V3D1534.5
V3D1831.5	V3D1834.5
V3D2131.5	V3D2134.5
V3D2431.5	V3D2434.5

V4D/CSB4D - Vanity Four Drawer

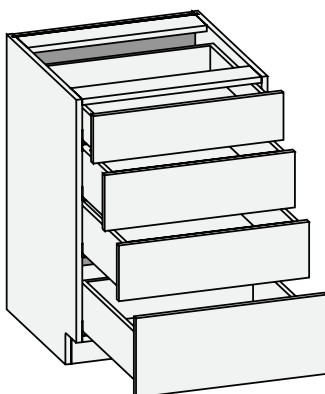

Custom Size Ranges
 Width: 12" – 39"
 Height: 31-1/2" – 34-1/2"
 Depth: 12", 13", 15", 16",
 18", 21", 24", 27",
 30"

- When height changes, lower drawer height changes.
- Upper drawer front heights fixed at 5-15/16".
- Middle drawer front heights fixed at 7".

21" Deep	
31-1/2" High	34-1/2" High
V4D1231.5	V4D1234.5
V4D1531.5	V4D1534.5
V4D1831.5	V4D1834.5
V4D2131.5	V4D2134.5
V4D2431.5	V4D2434.5

Vanity Options Key: FT = Flush Toe LTP = Loose Toe Platform STN = Square Toe Notch MCC = Matching Case Color NHH = No Hinge Holes
 NSH = No Shelf Holes NDSH = No Drawer Slide Holes

Design Notes:

Standard edgeband color matches cabinet interior color (Coastal White, Fog Grey or White Birch). Edgeband that matches doors/drawer fronts is available and must be specified. Upcharge applies. Use fillers when installing cabinets adjacent to walls and other cabinets to ensure adequate clearance for doors and drawers. Conestoga recommends that exposed ends be capped with 19mm thick applied decorative end panels (optional and must be specified). When this treatment is used, adjust cabinet width(s) accordingly.

VCL/CSVCL - Vanity Combination Left

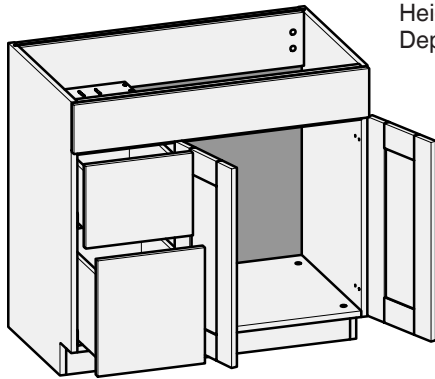

Custom Size Ranges
 Single Door Width: 30" – 36"
 Butt Door Width: 36" – 48"
 Height: 31-1/2" – 34-1/2"
 Depth: 12", 13", 15", 16",
 18", 21", 24", 27",
 30"

- False top drawer front.
- When height changes, lower opening heights change.
- Upper and middle drawer front heights fixed at 5-15/16" and 10".
- When width changes, door and false drawer opening changes.
- Lower drawer front widths fixed at 13".
- Specify single or butt doors on custom size cabinets 36" wide.
- When ordering a cabinet with a single door the standard hinge location is on the right using the standard Full Access Cabinetry (FAC) hinges. For applications requiring the door to be hinged on the left, omit hinges from cabinet and order FAC Partial Overlay Hinges (part#2103675).

Single Door Cabinets – 21" Deep		Butt Door Cabinets – 21" Deep	
31-1/2" High	34-1/2" High	34-1/2" High	34-1/2" High
VCL3031.5	VCL3034.5	VCL4231.5BD	VCL4234.5BD
VCL3331.5	VCL3334.5	VCL4831.5BD	VCL4834.5BD
VCL3631.5	VCL3634.5		

VCR/CSVCR - Vanity Combination Right

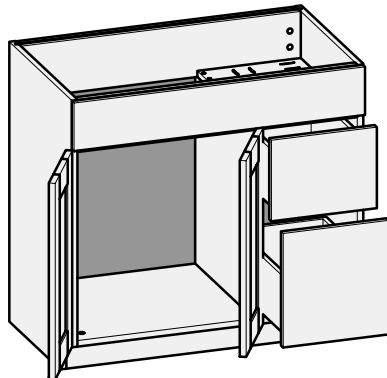

Custom Size Ranges
 Single Door Width: 30" – 36"
 Butt Door Width: 36" – 48"
 Height: 31-1/2" – 34-1/2"
 Depth: 12", 13", 15", 16",
 18", 21", 24", 27",
 30"

- False top drawer front.
- When height changes, lower opening heights change.
- Upper and middle drawer front heights fixed at 5-15/16" and 10".
- When width changes, door and false drawer opening changes.
- Lower drawer front widths fixed at 13".
- Specify single or butt doors on custom size cabinets 36" wide.
- When ordering a cabinet with a single door the standard hinge location is on the left using the standard Full Access Cabinetry (FAC) hinges. For applications requiring the door to be hinged on the right, omit hinges from cabinet and order FAC Partial Overlay Hinges (part#2103675).

Single Door Cabinets – 21" Deep		Butt Door Cabinets – 21" Deep	
31-1/2" High	34-1/2" High	34-1/2" High	34-1/2" High
VCR3031.5	VCR3034.5	VCR4231.5BD	VCR4234.5BD
VCR3331.5	VCR3334.5	VCR4831.5BD	VCR4834.5BD
VCR3631.5	VCR3634.5		

Vanity Options Key: FT = Flush Toe LTP = Loose Toe Platform STN = Square Toe Notch MCC = Matching Case Color NHH = No Hinge Holes
 NSH = No Shelf Holes NDSH = No Drawer Slide Holes

Design Notes:

Standard edgeband color matches cabinet interior color (Coastal White, Fog Grey or White Birch). Edgeband that matches doors/drawer fronts is available and must be specified. Upcharge applies. Use fillers when installing cabinets adjacent to walls and other cabinets to ensure adequate clearance for doors and drawers. Conestoga recommends that exposed ends be capped with 19mm thick applied decorative end panels (optional and must be specified). When this treatment is used, adjust cabinet width(s) accordingly.

VC3DL/CSVC3DL – Vanity Combo Three Drawer Left

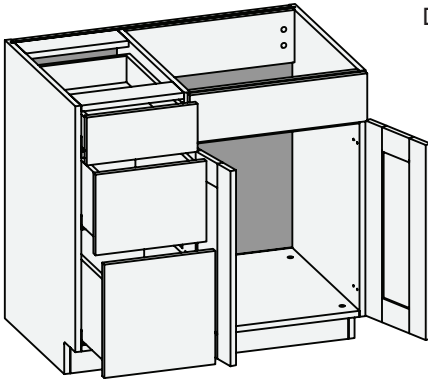

Custom Size Ranges
Width: 36" – 48"
Height: 31-1/2" – 34-1/2"
Depth: 12", 13", 15", 16",
18", 21", 24", 27",
30"

- When width changes, door opening remains fixed at 21".
- When height changes door and lower drawer opening heights change.
- Upper and middle drawer front heights fixed at 5-15/16" and 10".
- Specify single or butt doors on custom size cabinets.
- Standard hinge location is on the right using the standard Full Access Cabinetry (FAC) hinges. For applications requiring the door to be hinged on the left, omit hinges from cabinet and order FAC Partial Overlay Hinges (part#2103675).

Single Door Cabinets – 21" Deep		Butt Door Cabinets – 21" Deep	
31-1/2" High	34-1/2" High	31-1/2" High	34-1/2" High
VC3DL3631.5	VC3DL3634.5	VC3DL3631.5BD	VC3DL3634.5BD
VC3DL3931.5	VC3DL3934.5	VC3DL3931.5BD	VC3DL3934.5BD
VC3DL4231.5	VC3DL4234.5	VC3DL4231.5BD	VC3DL4234.5BD
VC3DL4531.5	VC3DL4534.5	VC3DL4531.5BD	VC3DL4534.5BD
VC3DL4831.5	VC3DL4834.5	VC3DL4831.5BD	VC3DL4834.5BD

VC3DR/CSVC3DR – Vanity Combo Three Drawer Right

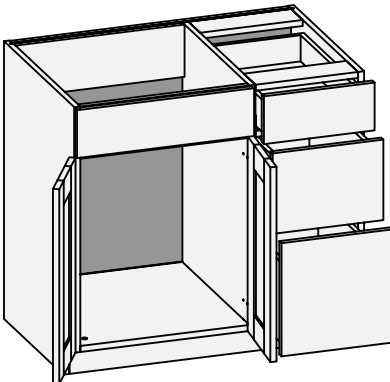

Custom Size Ranges
Width: 36" – 48"
Height: 31-1/2" – 34-1/2"
Depth: 12", 13", 15", 16",
18", 21", 24", 27",
30"

- When width changes, door opening remains fixed at 21".
- When height changes door and lower drawer opening height changes.
- Upper and middle drawer heights remain fixed at 5-15/16" and 10".
- Specify single or butt doors on custom size cabinets.
- Standard hinge location is on the left using the standard Full Access Cabinetry (FAC) hinges. For applications requiring the door to be hinged on the right, omit hinges from cabinet and order FAC Partial Overlay Hinges (part#2103675).

Single Door Cabinets – 21" Deep		Butt Door Cabinets – 21" Deep	
31-1/2" High	34-1/2" High	31-1/2" High	34-1/2" High
VC3DR3631.5	VC3DR3634.5	VC3DR3631.5	VC3DR3634.5
VC3DR3931.5	VC3DR3934.5	VC3DR3931.5	VC3DR3934.5
VC3DR4231.5	VC3DR4234.5	VC3DR4231.5	VC3DR4234.5
VC3DR4531.5	VC3DR4534.5	VC3DR4531.5	VC3DR4534.5
VC3DR4831.5	VC3DR4834.5	VC3DR4831.5	VC3DR4834.5

Vanity Options Key: FT = Flush Toe LTP = Loose Toe Platform STN = Square Toe Notch MCC = Matching Case Color NHH = No Hinge Holes
NSH = No Shelf Holes NDSH = No Drawer Slide Holes

Design Notes:

Standard edgeband color matches cabinet interior color (Coastal White, Fog Grey or White Birch). Edgeband that matches doors/drawer fronts is available and must be specified. Upcharge applies. Use fillers when installing cabinets adjacent to walls and other cabinets to ensure adequate clearance for doors and drawers. Conestoga recommends that exposed ends be capped with 19mm thick applied decorative end panels (optional and must be specified). When this treatment is used, adjust cabinet width(s) accordingly.

VC3D/CSVC3D – Vanity Combo Three Drawer w/Butt Doors

Custom Size Ranges
 Width: 48" – 72"
 Height: 31-1/2" – 34-1/2"
 Depth: 12", 13", 15, 16",
 18", 21", 24", 27", 30"

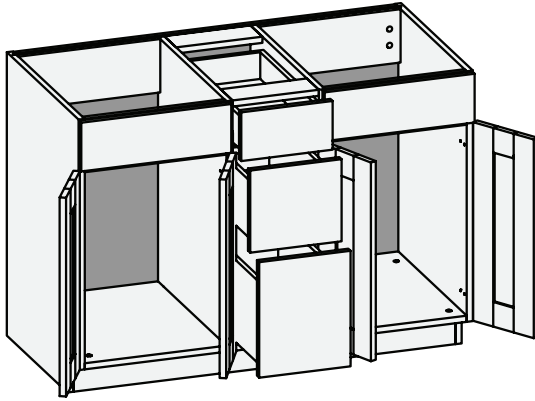

- Two false top drawer fronts, one functional top drawer.
- When height changes, doors and lower drawer front height changes.
- Upper and middle drawer front heights fixed at 5-15/16" and 10".
- When width changes, door openings and false drawer fronts change. Drawer openings remain fixed at 10-1/2" wide.

21" Deep	
31-1/2" High	34-1/2" High
VC3D6031.5BD	VC3D6034.5BD

VC6D/CSVC6D – Vanity Combo Six Drawer w/Butt Doors

Custom Size Ranges
 Width: 48" – 72"
 Height: 31-1/2" – 34-1/2"
 Depth: 12", 13", 15, 16",
 18", 21", 24", 27", 30"

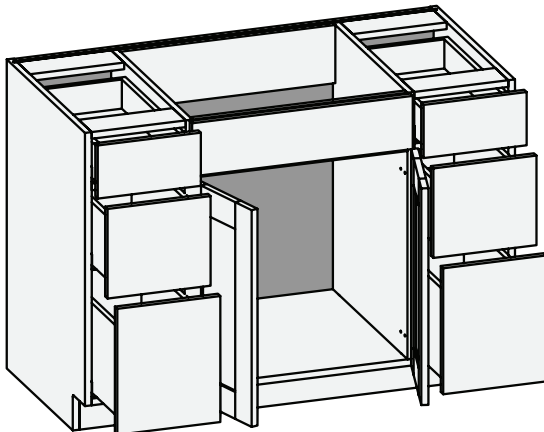

- One false top drawer front, two functional top drawers.
- When height changes, lower drawer front height changes.
- Upper and middle drawer front heights fixed at 5-15/16" and 10".
- When width changes, door opening and false drawer front changes. Drawer openings remain fixed at 10-1/2" wide.

21" Deep	
31-1/2" High	34-1/2" High
VC6D4831.5BD	VC6D4834.5BD
VC6D6031.5BD	VC6D6034.5BD

Vanity Options Key: FT = Flush Toe LTP = Loose Toe Platform STN = Square Toe Notch MCC = Matching Case Color NHH = No Hinge Holes
 NSH = No Shelf Holes NDSH = No Drawer Slide Holes

Design Notes:

Standard edgeband color matches cabinet interior color (Coastal White, Fog Grey or White Birch). Edgeband that matches doors/drawer fronts is available and must be specified. Upcharge applies. Use fillers when installing cabinets adjacent to walls and other cabinets to ensure adequate clearance for doors and drawers. Conestoga recommends that exposed ends be capped with 19mm thick applied decorative end panels (optional and must be specified). When this treatment is used, adjust cabinet width(s) accordingly.

WHV/CSWHV - Wall Hung Vanity

Custom Size Ranges
Single Door Width: 21" – 24"
Butt Door Width: 24" – 36"
Height: 18" – 24"
Depth: 18" - 21"

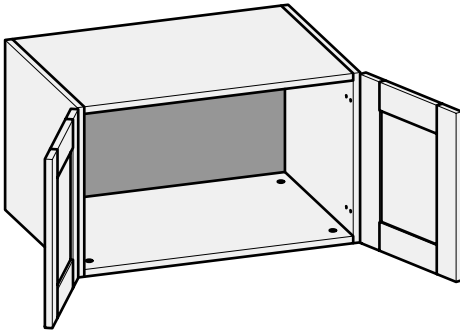

- The load capacity of these cabinets is greatly dependent on the quality of the installation screws and whether the cabinets are secured into the wall studs. If not secured into two or more studs, using high quality installation screws the cabinet may not support the desired weight.
- Conestoga will not be responsible for cabinet failure due to inadequate installation techniques or materials.
- Specify single or butt doors on custom size cabinets 24" wide.

Single Door Cabinets 21" Deep	Butt Door Cabinets 21" Deep
24" High	24" High
WHV2124	WHV2424BD
WHV2424	WHV2724BD
	WHV3024BD
	WHV3324BD
	WHV3624BD

WHV2D/CSWHV2D - Wall Hung Vanity 2 Drawers

Custom Size Ranges
Door Width: 21" – 36"
Height: 18" – 24"
Depth: 18" - 21"

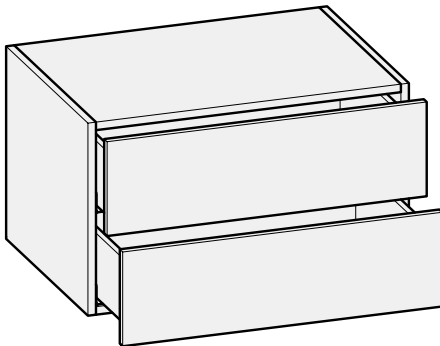

- The load capacity of these cabinets is greatly dependent on the quality of the installation screws and whether the cabinets are secured into the wall studs. If not secured into two or more studs, using high quality installation screws the cabinet may not support the desired weight.
- Conestoga will not be responsible for cabinet failure due to inadequate installation techniques or materials.
- Drawer front heights are equal.

21" Deep	
24" High	
WHV2D2124	WHV2D3024
WHV2D2424	WHV2D3324
WHV2D2724	WHV2D3624

Vanity Options Key: FT = Flush Toe LTP = Loose Toe Platform STN = Square Toe Notch MCC = Matching Case Color NHH = No Hinge Holes
NSH = No Shelf Holes NDSH = No Drawer Slide Holes

Design Notes:

Standard edgeband color matches cabinet interior color (Coastal White, Fog Grey or White Birch). Edgeband that matches doors/drawer fronts is available and must be specified. Upcharge applies. Use fillers when installing cabinets adjacent to walls and other cabinets to ensure adequate clearance for doors and drawers. Conestoga recommends that exposed ends be capped with 19mm thick applied decorative end panels (optional and must be specified). When this treatment is used, adjust cabinet width(s) accordingly.

CSUCR - Vanity Linen Base Height

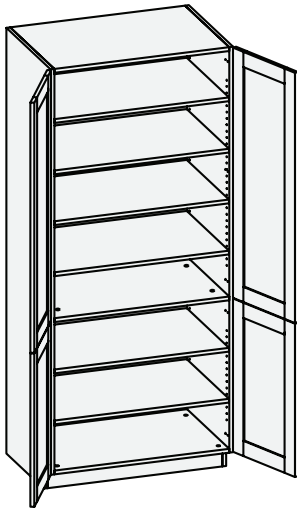

Custom Size Ranges
 Single Door Width: 12" – 24"
 Butt Width: 24" – 36"
 Height: 84" – 96"
 Depth: 8" – 30"

- Lower section below fixed shelf aligns with 34-1/2" high Vanity cabinets.
- 84" – 90" high has six shelves.
- 90-1/16" – 96" high has seven shelves.
- When height changes, upper opening height changes.
- Lower opening height fixed at 29-5/16".
- Specify single or butt doors on custom size cabinets 24" wide.
- Separate 4" high toe platform is available with all cabinet heights.

CSU3D - Vanity Linen Three Drawer Base Height

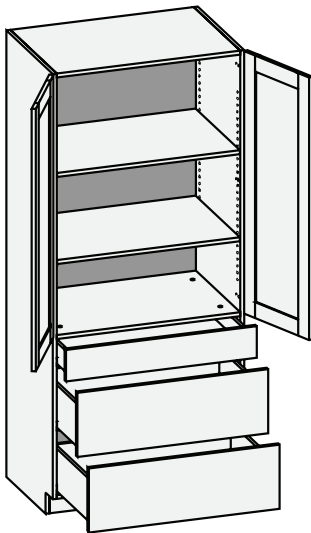

Custom Size Ranges
 Single Door Width: 12" – 24"
 Butt Door Width: 24" – 36"
 Height: 84" – 96"
 Depth: 12", 13", 15", 16",
 18", 21", 24", 27", 30"

- When height changes, upper opening height changes.
- Lower section aligns with 34-1/2" high Vanity cabinets.
- Drawer front heights fixed at 5-15/16", 10" and 14-1/16".
- 84" – 90" high has four shelves.
- 90-1/16" – 96" high has five shelves.
- Specify single or butt doors on custom size cabinets 24" wide.
- Separate 4" high toe platform is available with all cabinet heights.

Vanity Options Key: FT = Flush Toe LTP = Loose Toe Platform STN = Square Toe Notch MCC = Matching Case Color NHH = No Hinge Holes
 NSH = No Shelf Holes NDSH = No Drawer Slide Holes

Design Notes:

Standard edgeband color matches cabinet interior color (Coastal White, Fog Grey or White Birch). Edgeband that matches doors/drawer fronts is available and must be specified. Upcharge applies. Use fillers when installing cabinets adjacent to walls and other cabinets to ensure adequate clearance for doors and drawers. Conestoga recommends that exposed ends be capped with 19mm thick applied decorative end panels (optional and must be specified). When this treatment is used, adjust cabinet width(s) accordingly.

Vesta Home Office/Media Standard Features and Options:

The features below are standard on all Home Office/Media cabinets where the design permits. Standard features can be omitted as needed. The option to omit standard features as well as add design options can be quickly referenced at the bottom of each page in the Home Office/Media Section labeled “Home Office/Media Options Key”. For detailed descriptions and images of the options, see Options, Section 20 of this manual. Standard features and options are available on all Home Office/Media cabinets unless specifically noted as **Unavailable Options**.

Edgeband – Our Home Office/Media cabinets sides, tops, bottoms, mid-floors, and shelves are edgebanded on the front edges only. Interior parts such as uprights or other support members are edgebanded on visible edges. Edgeband color must be specified to either match the case color (standard offering) or door color if applicable (upcharge applies). When Door Matching Edgeband Option is selected the front edges of the sides, top, bottom, and mid-floor are edgebanded using the door color. The edgeband on shelves and interior parts will match the interior case color. The Door Matching Edgeband Option is available with all Allure DLV, Intrigue TTS, Strata TTS, Vogue TTS, Synchronicity High Gloss and Super Matte colors, as well as wood matching specie edgeband in Cherry, Hard Maple, Paint Grade, Red Oak, Rift Cut White Oak and Walnut.

5mm Shelf Holes – 5mm Shelf Holes are pre-drilled on 32mm centers on all cabinets with shelves. **No Shelf Holes (NSH)** and **Omit Shelving (OS)** Options are available on any Home Office/Media cabinet with shelves. If both the No Shelf Holes and Omit Shelving Options are required, both must be individually specified.

Hinge Hole Drilling – All Home Office/Media cabinets eligible to receive doors will include Blum Frameless INSERTA Hinges and are pre-drilled with 5mm holes to accept the EXPANDO Mounting Plates. A **No Hinge Hole (NHH)** Option is available on Home Office/Media cabinets that would typically include doors. Cabinet hinges can also be omitted, but must be changed from the default Yes to No. The No Hinge Holes Option does not remove hinges; No Hinges must be specified.

Drawer Slide Hole Drilling – All Home Office/Media cabinets that include drawer boxes also include Blum TANDEM Drawer Slides and are pre-drilled with 5mm holes for quick and easy installation. The **No Drawer Slide Hole (NDSH)** Option is available only on cabinets with drawer boxes. Drawer slides can be omitted, but must be changed from the default Yes to No. The No Drawer Slide Holes Option does not automatically remove drawer slides; No Drawer Slides must be specified.

Toe Kick – Most Home Office/Media Base and Home Office/Media Tall cabinets come with a 3-3/4” x 4” Toe Kick Notch standard. Cabinets with a Toe Kick are available with either the **Flush Toe (FT)** and **Square Toe Notch (STN)** Options. The Flush Toe Option removes the Toe Kick from the cabinet and brings the Toe Backer flush with the cabinet front edge. The Square Toe Notch Option makes the intersecting corner of the Toe Notch 90° to aid in toeboard installation.

Matching Case Color (MCC) – With the Matching Case Color Option, the door and drawer front color matches the cabinet interior, exterior and edgeband. The Matching Case Color Option is available with most Home Office/Media cabinets and produced in all Intrigue TTS, Strata TTS and Vogue TTS colors, as well as wood matching species edgeband in Cherry, Hard Maple, Paint Grade, Red Oak, Rift Cut White Oak and Walnut.

Loose Toe Platform (LTP) – With the Loose Toe Platform Option, the cabinet height is automatically reduced by 4” and is produced without a Toe Kick. A 4” platform is provided to achieve the desired finished cabinet height. When ordering the Loose Toe Platform Option, enter the desired cabinet height, deductions for the toe platform are calculated by Conestoga. Loose Toe Platform is available with most Home Office/Media Base and Tall cabinets. The Flush Toe and Square Toe Notch Options are not available with the Loose Toe Platform Option.

Home Office/Media Options Key: FT = Flush Toe LTP = Loose Toe Platform STN = Square Toe Notch MCC = Matching Case Color
NHH = No Hinge Holes NSH = No Shelf Holes NDSH = No Drawer Slide Holes

Design Notes:

Standard edgeband color matches cabinet interior (Coastal White, Fog Grey or White Birch). Edgeband that matches doors/drawer fronts is available and must be specified. Upcharge applies. Use fillers when installing cabinets adjacent to walls and other cabinets to ensure adequate clearance for doors and drawers. Conestoga recommends that exposed ends be capped with 19mm thick applied decorative end panels (optional and must be specified). When this treatment is used, adjust cabinet width(s) accordingly.

DB/CSDB - Desk Base

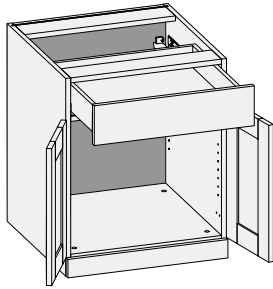

2-1/2" Bottom Rail

Custom Size Ranges
 Single Door Width: 12" – 24"
 Butt Door Width: 24" – 36"
 Height: 29-1/2"
 Depth: 18", 21", 24"

- Specify single or butt doors on custom size cabinets 24" wide.
- 2-1/2" high Flush Toe standard with 2-3/4" high decorative slab to conceal toe backer.
- Decorative slab can be omitted.
- Decorative slab mounts in front of toe kick and is produced in matching color when Coastal White, Fog Grey, White Birch or any eligible Matching Case Color (MCC) is ordered. If other color or specie is desired, omit decorative slab basic cabinet color and order the desired color or specie as a loose decorative slab.

Single Door Cabinets – 24" Deep		Butt Door Cabinet –24" Deep
DB1229.5	DB2129.5	DB2429.5BD
DB1529.5	DB2429.5	
DB1829.5		

DBFD/CSDBFD - Desk Base Full Door

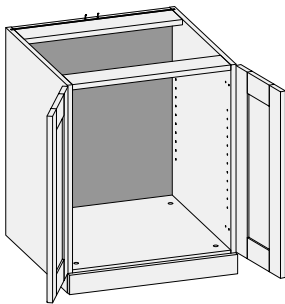

2-1/2" Bottom Rail

Custom Size Ranges
 Single Door Width: 12" – 24"
 Butt Door Width: 24" – 36"
 Height: 29-1/2"
 Depth: 18" – 30"

- Specify single or butt doors on custom size cabinets 24" wide.
- 2-1/2" high Flush Toe standard with 2-3/4" high decorative slab to conceal toe backer.
- Decorative slab can be omitted.
- Decorative slab mounts in front of toe kick and is produced in matching color when Coastal White, Fog Grey, White Birch or any eligible Matching Case Color (MCC) is ordered. If other color or specie is desired, omit decorative slab basic cabinet color and order the desired color or specie as a loose decorative slab.

Single Door Cabinets – 24" Deep		Butt Door Cabinet – 24" Deep
DBFD1229.5	DBFD2129.5	DBFD2429.5BD
DBFD1529.5	DBFD2429.5	
DBFD1829.5		

DB2D/CSDB2D - Desk Base Two Drawers

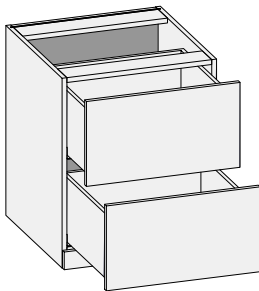

2-1/2" Bottom Rail

Custom Size Ranges
 Width: 12" – 36"
 Height: 29-1/2"
 Depth: 18", 21", 24"

- Both drawers designed to accommodate Pendaflex files.
- 15" width Pendaflex files must be installed front to back.
- 2-1/2" high Flush Toe standard with 2-3/4" high decorative slab to conceal toe backer.
- Decorative slab can be omitted.
- Decorative slab mounts in front of toe kick and is produced in matching color when Coastal White, Fog Grey, White Birch or any eligible Matching Case Color (MCC) is ordered. If other color or specie is desired, omit decorative slab basic cabinet color and order the desired color or specie as a loose decorative slab.

24" Deep	
DB2D1529.5	DB2D2129.5
DB2D1829.5	

Home Office/Media Options Key: FT = Flush Toe LTP = Loose Toe Platform STN = Square Toe Notch MCC = Matching Case Color
 NHH = No Hinge Holes NSH = No Shelf Holes NDSH = No Drawer Slide Holes

Design Notes:

Standard edgeband color matches cabinet interior (Coastal White, Fog Grey or White Birch). Edgeband that matches doors/drawer fronts is available and must be specified. Upcharge applies. Use fillers when installing cabinets adjacent to walls and other cabinets to ensure adequate clearance for doors and drawers. Conestoga recommends that exposed ends be capped with 19mm thick applied decorative end panels (optional and must be specified). When this treatment is used, adjust cabinet width(s) accordingly.

LF2D/CSLF2D - Lateral File Two Drawer

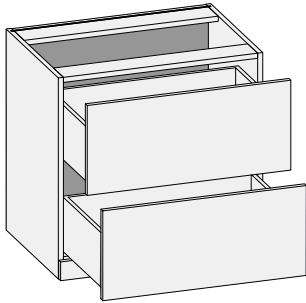

2-1/2" Bottom Rail

Custom Size Ranges
 Width: 30" – 36"
 Height: 29-1/2"
 Depth: 21"

- Full extension interlocking drawer slides only.
- 2-1/2" high Flush Toe standard with 2-3/4" high decorative slab to conceal toe backer.
- Decorative slab can be omitted.
- Decorative slab mounts in front of toe kick and is produced in matching color when Coastal White, Fog Grey, White Birch or any eligible Matching Case Color (MCC) is ordered. If other color or specie is desired, omit decorative slab basic cabinet color and order the desired color or specie as a loose decorative slab.

21" Deep	
LF2D3029.5	LF2D3629.5

DB3D/CSDB3D - Desk Base Three Drawers

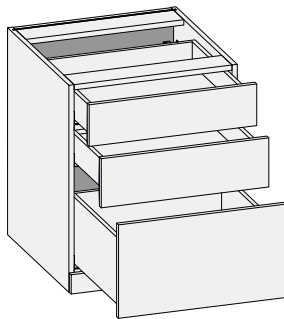

2-1/2" Bottom Rail

Custom Size Ranges
 Width: 12" – 36"
 Height: 29-1/2"
 Depth: 18", 21", 24"

- Bottom drawer designed to accommodate Pendaflex files.
- 15" width Pendaflex files must be installed front to back.
- 2-1/2" high Flush Toe standard with 2-3/4" high decorative slab to conceal toe backer.
- Decorative slab can be omitted.
- Decorative slab mounts in front of toe kick and is produced in matching color when Coastal White, Fog Grey, White Birch or any eligible Matching Case Color (MCC) is ordered. If other color or specie is desired, omit decorative slab basic cabinet color and order the desired color or specie as a loose decorative slab.

24" Deep	
DB3D1529.5	DB3D2129.5
DB3D1829.5	DB3D2429.5

DD/CSDD - Desk Drawer

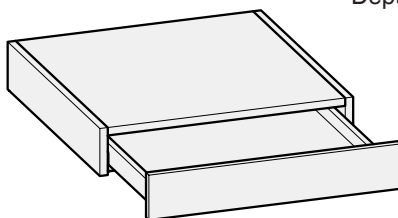

Custom Size Ranges
 Width: 12" – 36"
 Height: 4-1/2"
 Depth: 18", 21", 24"

- No bottom or bottom rail.

24" Deep	
DD184.5	DD304.5
DD214.5	DD334.5
DD244.5	DD364.5
DD274.5	

Home Office/Media Options Key: FT = Flush Toe LTP = Loose Toe Platform STN = Square Toe Notch MCC = Matching Case Color
 NHH = No Hinge Holes NSH = No Shelf Holes NDSH = No Drawer Slide Holes

Design Notes:

Standard edgeband color matches cabinet interior (Coastal White, Fog Grey or White Birch). Edgeband that matches doors/drawer fronts is available and must be specified. Upcharge applies. Use fillers when installing cabinets adjacent to walls and other cabinets to ensure adequate clearance for doors and drawers. Conestoga recommends that exposed ends be capped with 19mm thick applied decorative end panels (optional and must be specified). When this treatment is used, adjust cabinet width(s) accordingly.

W1D/CSW1D - Wall One Drawer w/Butt Doors

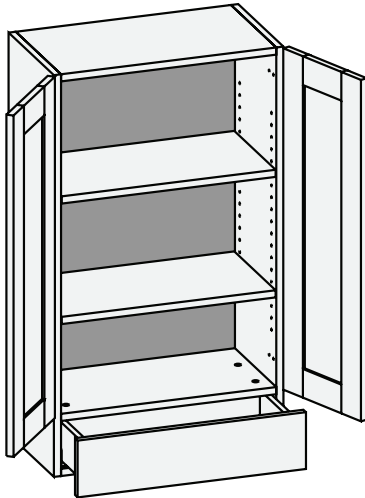

Custom Size Ranges
Single Door Width: 12" – 24"
Butt Door Width: 24" – 36"
Height: 30" – 72"
Depth: 13", 16", 18", 21", 24"

- When height changes, upper opening height changes. Lower drawer front height fixed at 5-15/16".
- 30" – 35-15/16" high has one shelf.
- 36" – 47-15/16" high has two shelves.
- 48" – 59-15/16" high has three shelves.
- 60" – 72" high has four shelves.
- Specify single or butt doors on custom size cabinets 24" wide.

Single Door Cabinets – 13" Deep		
53" High	59" High	65" High
W1D1553	W1D1559	W1D1565
W1D1853	W1D1859	W1D1865
W1D2153	W1D2159	W1D2165
W1D2453	W1D2459	W1D2465
Butt Door Cabinets – 13" Deep		
53" High	59" High	65" High
W1D2453BD	W1D2459BD	W1D2465BD
W1D2753BD	W1D2759BD	W1D2765BD
W1D3053BD	W1D3059BD	W1D3065BD
W1D3353BD	W1D3359BD	W1D3365BD
W1D3653BD	W1D3659BD	W1D3665BD

W2D/CSW2D - Wall Two Drawer

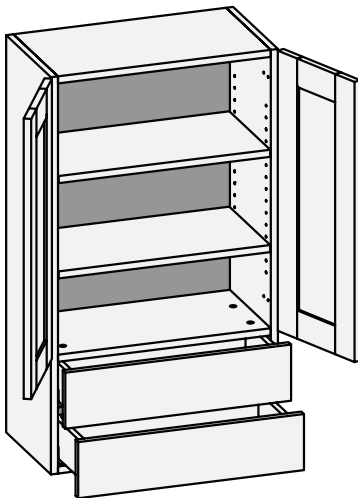

Custom Size Ranges
Width: 24" – 36"
Height: 30" – 66"
Depth: 13", 16", 18", 21", 24"

- When height changes, upper opening height changes. Lower opening contains two drawer fronts with height fixed at 5-15/16".
- 30" – 41-15/16" high has one shelf.
- 42" – 47-15/16" high has two shelves.
- 48" – 59-15/16" high has three shelves.
- 60" – 66" high has four shelves.
- Specify single or butt doors on custom size cabinets 24" wide.

Single Door Cabinets – 13" Deep		
48" High	54" High	60" High
W2D1548	W2D1554	W2D1560
W2D1848	W2D1854	W2D1860
W2D2148	W2D2154	W2D2160
W2D2448	W2D2454	W2D2460
Butt Door Cabinets – 13" Deep		
48" High	54" High	60" High
W2D2448BD	W2D2454BD	W2D2460BD
W2D2748BD	W2D2754BD	W2D2760BD
W2D3048BD	W2D3054BD	W2D3060BD
W2D3348BD	W2D3354BD	W2D3360BD
W2D3648BD	W2D3654BD	W2D3660BD

Home Office/Media Options Key: FT = Flush Toe LTP = Loose Toe Platform STN = Square Toe Notch MCC = Matching Case Color
NHH = No Hinge Holes NSH = No Shelf Holes NDSH = No Drawer Slide Holes

Design Notes:

Standard edgeband color matches cabinet interior (Coastal White, Fog Grey or White Birch). Edgeband that matches doors/drawer fronts is available and must be specified. Upcharge applies. Use fillers when installing cabinets adjacent to walls and other cabinets to ensure adequate clearance for doors and drawers. Conestoga recommends that exposed ends be capped with 19mm thick applied decorative end panels (optional and must be specified). When this treatment is used, adjust cabinet width(s) accordingly.

WOBS/CSWOBS - Wall Open Bookshelf

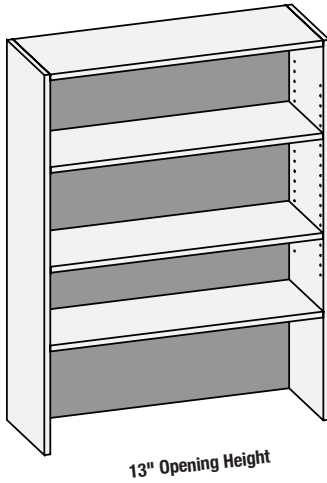

Custom Size Ranges
Width: 9" – 36"
Height: 24" – 96"
Depth: 8" – 27"

- 24" – 35-15/16" high has one fixed.
- 36" – 47-15/16" high has one fixed and one adjustable shelf.
- 48" – 59-1/16" high has one fixed and two adjustable shelves.
- 60" – 72" high has one fixed and three adjustable shelves.
- 72-1/16" – 84" has one fixed and four adjustable shelves.
- 84-1/16" – 96" has one fixed and five adjustable shelves.

13" Deep		
53" High	59" High	65" High
WOBS1553	WOBS1559	WOBS1565
WOBS1853	WOBS1859	WOBS1865
WOBS2153	WOBS2159	WOBS2165
WOBS2453	WOBS2459	WOBS2465
WOBS2753	WOBS2759	WOBS2765
WOBS3053	WOBS3059	WOBS3065
WOBS3353	WOBS3359	WOBS3365
WOBS3653	WOBS3659	WOBS3665

WOBSCS/CSWOBSCS - Wall Open Bookshelf w/ Center Stile

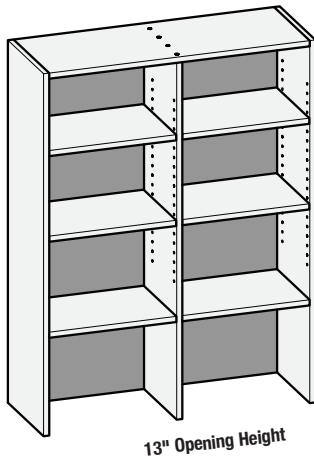

Custom Size Ranges
Width: 36" – 72"
Height: 24" – 96"
Depth: 8" – 27"

- Fixed vertical partition with independently adjustable shelves.
- 24" – 35-15/16" high has two fixed shelves.
- 36" – 47-15/16" high has two fixed and two adjustable shelves.
- 48" – 59-1/16" high has two fixed and four adjustable shelves.
- 60" – 72" high has two fixed and six adjustable shelves.
- 72-1/16" – 84" has two fixed and eight adjustable shelves.
- 84-1/16" – 96" has two fixed and ten adjustable shelves.

13" Deep		
48" High	54" High	60" High
WOBSCS3648	WOBSCS3654	WOBSCS3660
WOBSCS3948	WOBSCS3954	WOBSCS3960
WOBSCS4248	WOBSCS4254	WOBSCS4260
WOBSCS4548	WOBSCS4554	WOBSCS4560
WOBSCS4848	WOBSCS4854	WOBSCS4860
WOBSCS5148	WOBSCS5154	WOBSCS5160
WOBSCS5448	WOBSCS5454	WOBSCS5460
WOBSCS5748	WOBSCS5754	WOBSCS5760
WOBSCS6048	WOBSCS6054	WOBSCS6060
WOBSCS6348	WOBSCS6354	WOBSCS6360
WOBSCS6648	WOBSCS6654	WOBSCS6660
WOBSCS6948	WOBSCS6954	WOBSCS6960
WOBSCS7248	WOBSCS7254	WOBSCS7260

Home Office/Media Options Key: FT = Flush Toe LTP = Loose Toe Platform STN = Square Toe Notch MCC = Matching Case Color
NHH = No Hinge Holes NSH = No Shelf Holes NDSH = No Drawer Slide Holes

Design Notes:

Standard edgeband color matches cabinet interior (Coastal White, Fog Grey or White Birch). Edgeband that matches doors/drawer fronts is available and must be specified. Upcharge applies. Use fillers when installing cabinets adjacent to walls and other cabinets to ensure adequate clearance for doors and drawers. Conestoga recommends that exposed ends be capped with 19mm thick applied decorative end panels (optional and must be specified). When this treatment is used, adjust cabinet width(s) accordingly.

WEP – Wall End Panel

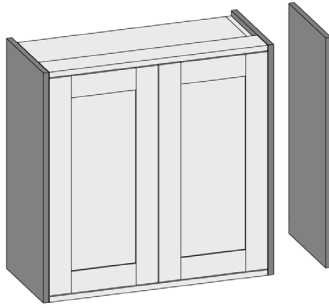

- When ordering Wall End Panel (WEP) enter cabinet depth and height and system will add 7/8" to width and 1-1/2" to the length of the panel to give the cabinet an inset look.
- WEPs are edgebanded on 4 sides with door matching edgeband color.
- For Intrigue TTS, Strata TTS and Vogue TTS doors the WEP material color will automatically configure to match the door material color.
- When wood doors with or without a finish are selected the plywood WEP is configured to match specie and finish if applicable (Cherry, Hard Maple, Paint Grade, Red Oak, Rift Cut White Oak and Walnut only).
- When using Con-Nex, select drop down in "Finish Side Left/Finish Side Right" to automatically configure WEP for cabinet.

BEP – Base End Panel

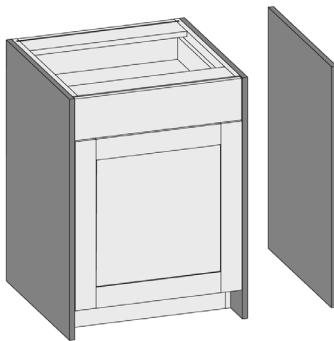

- When ordering Base End Panel (BEP) enter cabinet depth and height and system will add 7/8" to width of the panel to give the cabinet an inset look.
- BEPs are edgebanded on 4 sides with door matching edgeband color.
- For Intrigue TTS, Strata TTS and Vogue TTS doors the BEP material color will automatically configure to match the door material color.
- When wood doors, with or without a finish are selected the plywood BEP is configured to match specie and finish if applicable (Cherry, Hard Maple, Paint Grade, Red Oak, Rift Cut White Oak and Walnut only).
- When using Con-Nex, select drop down in "Finish Side Left/Finish Side Right" to automatically configure BEP for cabinet.
- BEP can also be used in conjunction with Wall and Tall cabinets when a flush top and bottom between cabinet and end panel is desired.

TEP – Tall End Panel

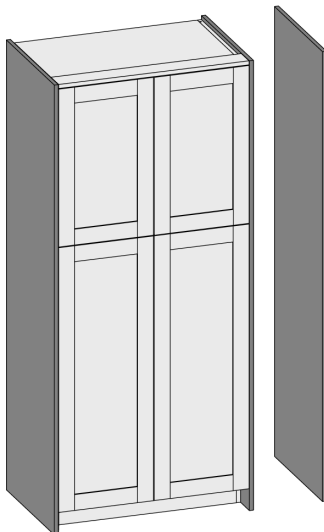

- When ordering Tall End Panel (TEP) enter cabinet depth and height and the system will add 7/8" to width and 3/4" to the length of the panel to give the cabinet an inset look.
- TEPs are edgebanded on 4 sides with door matching edgeband color.
- For Intrigue TTS, Strata TTS and Vogue TTS doors the TEP material color will automatically configure to match the door material color.
- When wood doors, with or without finish are selected, the plywood TEP is configured to match to specie and finish if applicable (Cherry, Hard Maple, Paint Grade, Red Oak, Rift Cut White Oak and Walnut only).
- When using Con-Nex select drop down in "Finish Side Left/Finish Side Right" to automatically configure TEP for cabinet.
- TEP can also be used in conjunction with Wall cabinets when a flush top or bottom between cabinet and end panel is desired.

TP/CSTP – Trim Panel

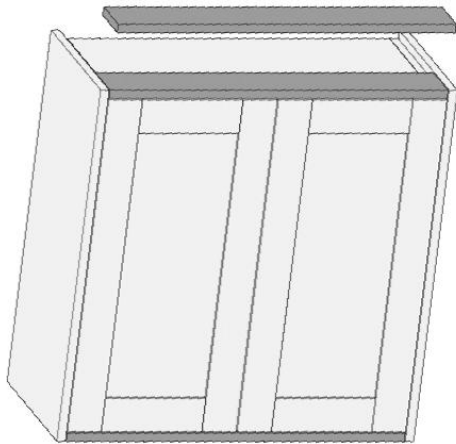

- Trim Panels (TP) are edgebanded on 4 sides with door matching edgeband color.
- When ordering CSTP enter desired finished sizes.
- For Intrigue TTS, Strata TTS and Vogue TTS doors the TP material color will automatically configure to match the door material color.
- When wood doors with or without finish are selected, the plywood TP is configured to match the specie and finish (Cherry, Hard Maple, Paint Grade, Red Oak, Rift Cut White Oak and Walnut only).

SKU	Dimensions
TP0390	3" X 90"
TP0396	3" X 96"
TP1390	13-7/8" X 90"
TP1396	13-7/8" X 96"
TP1690	16-7/8" X 90"
TP1696	16-7/8" X 96"

FS/CSFSW - Filler Strip (Wall)

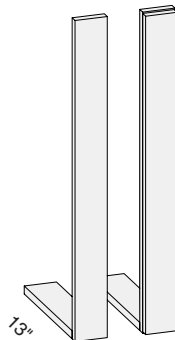

CSFSW (with overlay)

Custom Size Ranges
 Width: 3" and 6" only
 Height: 12" – 72"
 Depth: 5-1/2" – 27"

- Order with or without 3/4" thick slab overlay.
- 3/4" thick slab overlay matches door color or door specie and finish.
- MCC available in Intrigue TTS, Strata TTS and Vogue TTS colors.

30" High	42" High
FS0330	FS0342
FS0630	FS0642

FS/CSFSB - Filler Strip (Base)

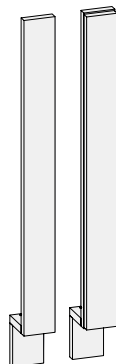

CSFSB (with overlay)

FS

Custom Size Ranges
 Width: 3" and 6" only
 Height: 31-1/2" – 96"
 Depth: 4"

- Order with or without 3/4" thick slab overlay.
- 3/4" thick slab overlay matches door color or door specie and finish.
- MCC available in Intrigue TTS, Strata TTS and Vogue TTS colors.

34-1/2" High	84" High	96" High
FS0334.5	FS0684	FS0396
FS0634.5	FS0384	FS0696

TTS Narrow Overlay Filler (Intrigue, Strata and Vogue)

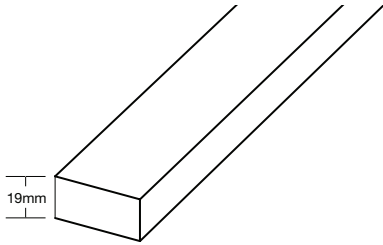

- Alternative Material Narrow Overlay Fillers (19mm thick) can be applied to installation fillers for full overlay trim applications.
- Filler width can be customized in 1/16" increments from 1-1/2" to 2-11/16" in width and lengths from 12" to 96".
- All edges are banded with matching edgeband – no option.
- Sold in pairs – no option.

TTS L-Moulding (Intrigue, Strata and Vogue)

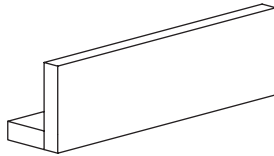

- Accent or trim moulding can be used as fascia or under cabinets as light rail.
- Face width can be customized in 1/16" increments from 2-3/4" to 8". Mounting plate is 2-3/4" wide - not customizable.
- L-Moulding length can be customized in 1/16" increments from 12" to 96".
- Matching color edgeband is standard. All edges are banded, including ends.

TTS Scribe Moulding (Intrigue, Strata and Vogue)

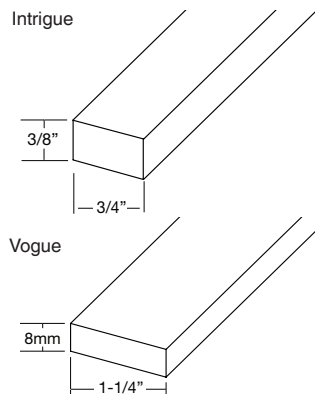

- Intrigue TTS Scribe Moulding is 3/8" thick x 3/4" wide x 96" long.
- Intrigue TTS Scribe is manufactured utilizing 19mm edgebanded panels, edgebanded on the face and both short edges of the moulding, while the two 3/8" thick long edges are the matching TFL board surface. The back of the moulding is uncoated for installation.
- Strata TTS and Vogue TTS Scribe Moulding is 8mm thick x 1-1/4" wide x 96" long.
- Strata TTS and Vogue TTS Scribe is manufactured utilizing edgebanded 8mm material, banded on one long edge and both short edges with matching edgeband.
- Moulding Cut-Down Option is available, but will remove one short edgebanded end.
- Sold in pairs – no option.

Standard Lazy Susan Shelves

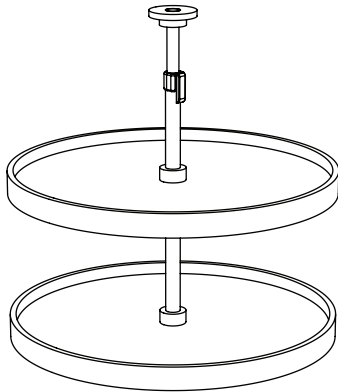

- White plastic susan with two independently rotating shelves mounted on a center pole.
- Shelves feature self lubricating nylon bearing and tool-free height adjustment.
- When standard lazy susan shelves are ordered, cabinet interior shelves are automatically omitted.
- See Con-Nex® for standard lazy susan upgrade pricing.

Part No.	Sized for Cabinet	Description
2102946	WCS/CSWCSE (30" High) WCA/CSWCA (48" High) TTWCSE/CSTTWCSE (48" High)	18" Full Round
2102947	BCFD/CSBCFD	32" Full Round
2102948	BLS/CSBLS	32" Kidney
2102949	BLS30/CSBLS30	24" Kidney

CSFFK – Loose Fixed Floor Kit

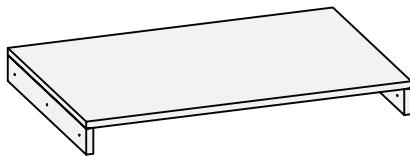

- Use Loose Fixed Floor Kits to horizontally segment almost any cabinet.
- Loose Fixed Floor Kits are sized to fit between side panels.
- To order specify CSFFK and the cabinet width and depth. Conestoga calculates the kit dimension based on the cabinet interior dimension.
- Use Conestoga's online ordering system, Con-Nex® or Conestoga order entry for pricing.

CSLTP – Loose Toe Platform / Prep Loose for Toe Platform

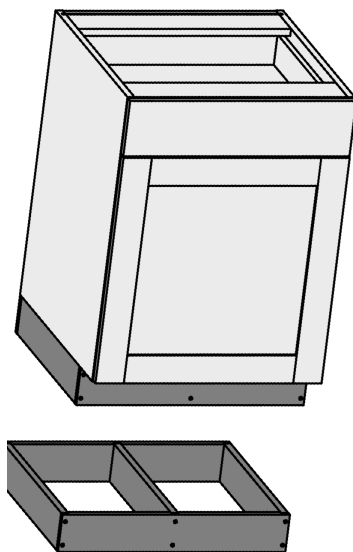

Custom Size Ranges
Width: 9" - 96"
Height: 4" fixed
Depth: 12" - 30"

- Loose Toe Platform is made with 3/4" prefinished Birch plywood regardless of cabinet material. Use end panels and Toeboard Strips to conceal Loose Toe Platform.
- When ordering as a cabinet option, specify Loose Toe Platform or Prep for Loose Toe Platform. Enter the desired cabinet width, height and depth. The system will automatically subtract 4" from the cabinet height and remove the toe kick to account for the Loose Toe Platform.
- Loose Toe Platform Option includes the Loose Toe Platform with the cabinet and does not need to be ordered separately.
- Prep for Loose Toe Platform Option reduces the cabinet height by 4" and removes the toe kick. Loose Toe Platform must be ordered separately.
- When ordering a custom size Loose Toe Platform independent of a cabinet, specify cabinet/cabinet run width and depth. Loose Toe Platform depth will be adjusted 3-3/4" to account for toe kick depth. Select Flush Toe Option to bring Loose Toe Platform flush with the cabinet front.
- Available on most cabinets that have a toe kick.

ROS/CSROS – Roll Out Shelf

Custom Size Ranges
Width: 24" – 36"
Depth: 18", 21", 24",
27", 30"

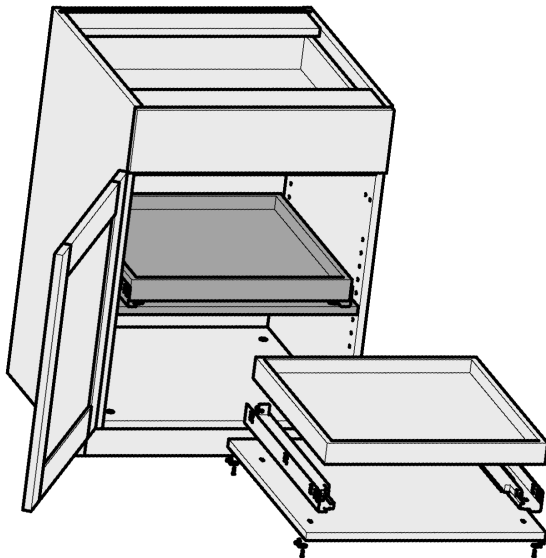

- Roll-Out Shelf (ROS) units can be added to most Full Access cabinets that have shelves 18" to 30" in depth.
- Each ROS unit contains one pre-drilled shelf, one set of Blum TANDEM Slides, Shelf Clips, and Screws. All provided shelf clips and screws must be used when installing ROS to prevent the shelf from tipping when fully extended. Conestoga will not be responsible for ROS failure or injury due to improper or incomplete installation.
- Standard drawer box height is 2". Taller drawer boxes are available and must be specified.
- When ordering ROS enter cabinet width and depth to get the correct size ROS unit. Remember to omit shelving in the cabinet to avoid having extra shelves.
- No Shelf Option is available when adding a loose ROS unit to an existing shelf or fixed cabinet floor. When No Shelf Option is selected, predrilled shelf is omitted, and customer is required to drill holes for slides. Drill locations are provided on the ROS assembly instructions.
- 27" & 30" deep cabinets use a 24" deep Blum TANDEM Slide. Drawer boxes will be manufactured at full depth with a spacer to accommodate the shorter slide length. When fully extended drawer boxes in deeper cabinet depths will not extend beyond the front of the cabinet.
- In Con-Nex, ROS units can be ordered as an option on a cabinet and all cabinet modifications will occur automatically.

CSPOTB – Pull-Out Tray Base

Custom Size Ranges
 Width: 15" – 36"
 Depth: 15", 18", 21",
 24", 27", 30"

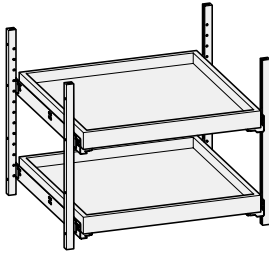

- CSPOTB includes 2 drawer boxes with a 2" height standard. Drawer box quantity and height is customizable.
- Each kit includes the following items.
 - ◆ 4 Prefinished Hard Maple Pilasters.
 - ◆ 1 hardware pack and 1 set of TANDEM Drawer Slides per drawer box.
- Pilaster length is 19-5/8" and fits a standard Base cabinet. Pilasters can be trimmed or stacked to fit most cabinet configurations.

CSPOTBFD – Pull-Out Tray Base Full Door

Custom Size Ranges
 Width: 15" – 36"
 Depth: 15", 18", 21",
 24", 27", 30"

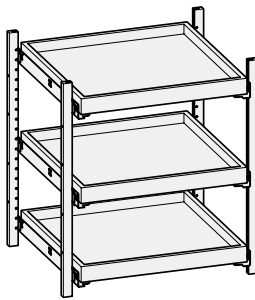

- CSPOTBFD includes 3 drawer boxes with a 2" height standard. Drawer box quantity and height is customizable.
- Each kit includes the following items
 - ◆ 4 Prefinished Hard Maple Pilasters.
 - ◆ 1 hardware pack and 1 set of TANDEM Drawer Slides per drawer box.
- Pilaster length is 27-3/16" and fits a standard Base full door cabinet. Pilasters can be trimmed or stacked to fit most cabinet configurations.

CSPOTU – Pull-Out Tray Utility

Custom Size Ranges
 Width: 15" – 36"
 Depth: 15", 18", 21",
 24", 27", 30"

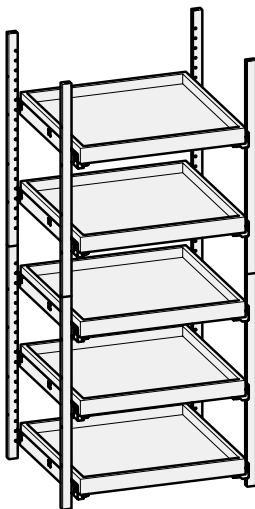

- CSPOTU includes 5 drawer boxes with a 2" height standard. Drawer box quantity and height is customizable.
- Each kit comes with the following items
 - ◆ 8 Prefinished Hard Maple Pilasters.
 - ◆ 1 hardware pack and 1 set of TANDEM Drawer Slides per drawer box.
- Pilaster length is 27-3/16" and is stacked to fit in a standard Utility cabinet. Pilasters can be trimmed or stacked to fit most cabinet configurations.

Vesta Standard Options

Omit Shelving (OS)

- Omits interior shelving in Wall, Base and Tall cabinets.
- Wall and Base Omit Shelving Option deletes all shelves.
- Tall cabinets: specify top, bottom or all shelves.
- Omits shelving only; if shelf holes are not required, specify No Shelf Hole Option.
- Use Conestoga's online ordering system, Con-Nex or Conestoga order entry for pricing.

No Shelf Hole Option (NSH)

- Omits shelf holes in Wall, Base and Tall cabinets.
- Most Wall and all Base, the No Shelf Hole Option deletes all holes.
- Two Tiered Wall cabinets (TTW) and Tall cabinets: specify top, bottom or all holes.
- Omit shelf holes only; if shelves are not required, also specify Omit Shelving Option.
- No upcharge.

No Hinge Hole Drilling (NHH)

- Omits 5mm hinge hole boring on any cabinet that is preconfigured with doors.
- Most Wall and all Base cabinets, the No Hinge Hole Drilling Option deletes all hinge holes.
- Two Tiered Wall and Tall cabinets: specify top, bottom, or all hinge holes.
- Omits hinge holes only; if hinges are not required, also specify Omit Hinges.
- No upcharge.

No Drawer Slide Hole Drilling (NDSH)

- Omits 5mm drawer slide hole boring on any cabinet that is preconfigured with drawers.
- No Drawer Slide Hole Drilling Option deletes all drawer slide holes.
- Omits drawer slide holes only; if drawer slides are not required, also specify omit drawer slides.
- No upcharge.

Matching Case Color (MCC)

- Cabinet interior, exterior, and edgeband color match the door and drawer front color.
- Available on most Vesta cabinet configurations unless specifically noted as Unavailable Option.
- Matching Case Color is available in all published Intrigue TTS, Strata TTS and Vogue TTS colors.

Exposed Ends (EXP)

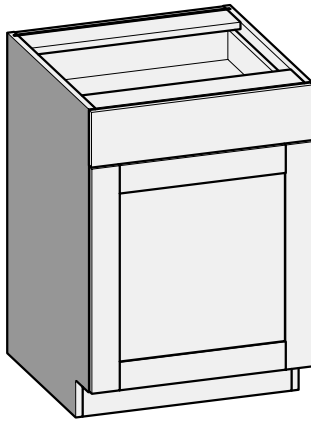

- Matching specie veneer on exterior cabinet sides with UV topcoat White Birch interior.
- Specify: “L” (Left), “R” (Right) or “B” (Both).
- Use Conestoga’s online ordering system, Con-Nex or Conestoga order entry for pricing.

Dust Top (DT)

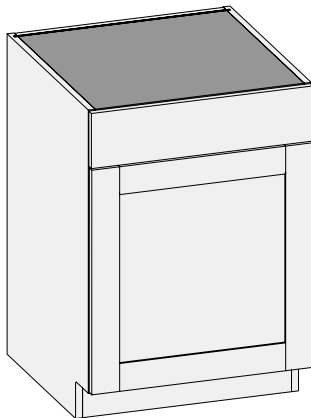

- Full top in place of stringers.
- Use Conestoga’s online ordering system, Con-Nex or Conestoga order entry for pricing.

Custom Top and Bottom Reveals (CTR & CBR)

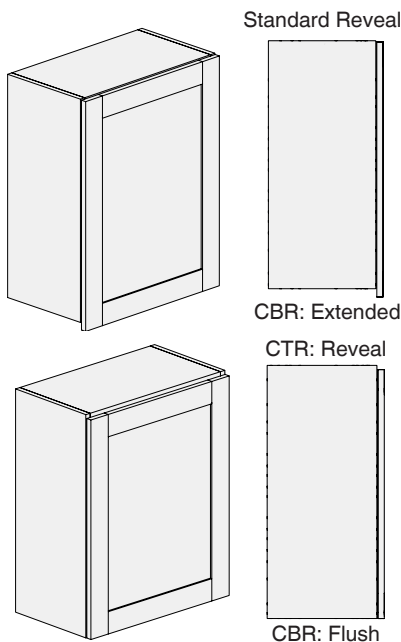

- Reduces or increases door height based on desired reveal on the top or bottom of door.
- Three reveal options are available that can be used in conjunction with each other. Illustration shows one example of each along with the standard reveal.
- Flush (F) – Door is flush with top or bottom of cabinet.
- Reveal (R) – Reveal is the distance from end of door to top or bottom of cabinet. Customizable in 1/16” increments from 1/16” to 3/4”.
- Extended (E) – Extends door past the top or bottom of cabinet. Customizable in 1/16” increments from 1/16” to 1”.
- Specify CTR for custom top reveal followed by the desired reveal or extension.
- Specify CBR for custom bottom reveal followed by the desired reveal or extension.
- When Flush is selected, the distance is set to zero.
- Predrilled hinge hole locations on cabinet sides are adjusted automatically based on reveals selected.

Increased Side Reveal (ISR)

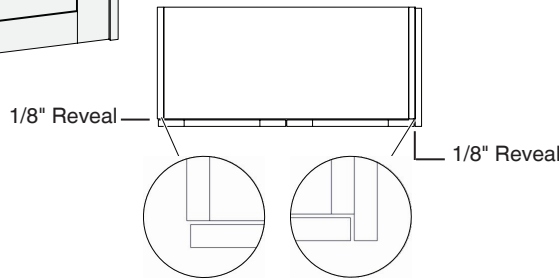
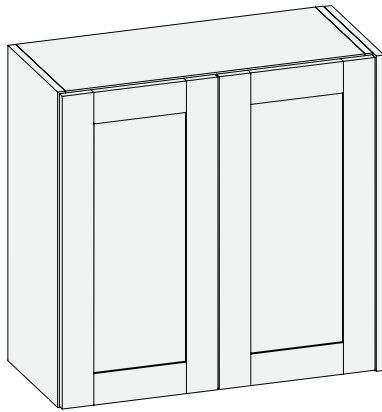

- Reduces door or drawer front width to provide 1/8" reveal at the end of a run to maintain standard 1/8" reveals.
- Top & Bottom reveal remain unchanged.
- Specify ISR right, Left, or Both.
- Available on most Wall, Base, Tall, and Vanity Cabinets.
- Available on most Base and Tall cabinets.
- Use Conestoga's online ordering system, Con-Nex or Conestoga order entry for pricing.

Toeboard Strips

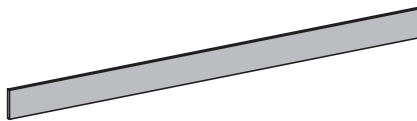

- TE2001 - 3/4" thick particleboard core 96" x 4".
- Toeboard Strips are edgebanded on 4 edges.
- Material colors – All published Intrigue TTS, Strata TTS and Vogue TTS colors.
- Order as a loose part; specify material color.
- Moulding Cut-Down Option is available on Toeboard Strips to combat the exorbitant fees freight carriers are charging for packages 96" or longer.
- Option cuts down Toeboard Strip to 90".
- To order specify "Cut-Down to 90 Inch" Option.

Plywood Toeboard Strips

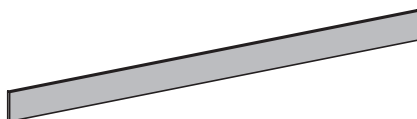

Plywood Toeboard Strips TE5003 (96" x 4")	
Specie	
Cherry	
Maple,Hard	
Oak, Red	

- 1/2" thick 96" x 4" Plywood Toeboard Strips available in Cherry, Hard Maple or Red Oak.
- Order as a loose part; specify specie.
- Moulding Cut-Down Option is available on Plywood Toeboard Strips to combat the exorbitant fees freight carriers are charging for packages 96" or longer.
- Option cuts down Toeboard Strip to 90".
- To order specify "Cut-Down to 90 Inch" Option.
- Upcharge applies; use Conestoga's online ordering system, Con-Nex or Conestoga order entry for pricing.

Square Toe Notch Option (STN)

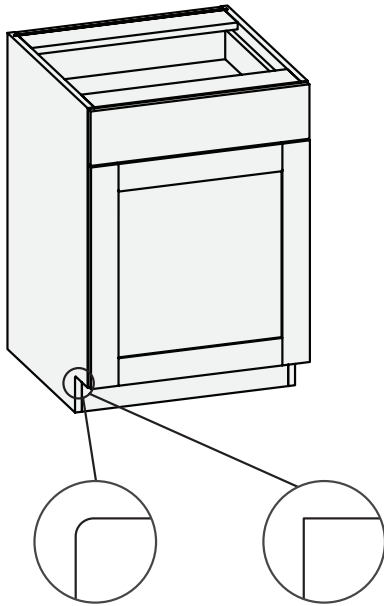

Standard 1/4" radius

90° Square Toe Notch

- Intersecting corner of Toe Kick Notch is 90°.
- Aids in Toeboard installation.
- Available on most Base, Tall and Vanity cabinets.
- Not available with Flush Toe.
- Use Conestoga's online ordering system, Con-Nex or Conestoga order entry for pricing.

Flush Toe (FT)

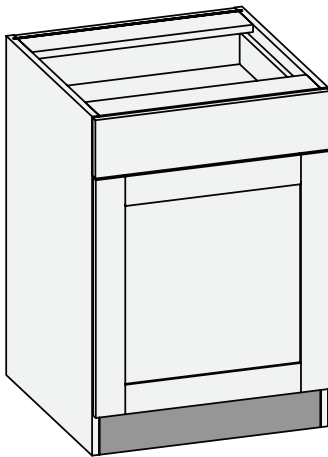

- Plywood toe backer height is 4". Toeboard strip must be ordered to provide finished appearance. If ordering wood doors, order the Scribe #2317 or 1/4" Solid Reface Moulding #2073.
- Specify: "FT" (Flush Toe).
- Cabinet side is manufactured without toe notch.
- 96" tall cabinets do not use a toe platform.
- Available on most Base and Tall cabinets.
- Use Conestoga's online ordering system, Con-Nex or Conestoga order entry for pricing.

Drawer Slide Options

Blum TANDEM Plus BLUMOTION Integrated Soft Close for Full Access Cabinetry

- Standard slide for most base and tall cabinets is 24".
- Optional slides for drawer boxes in 12", 15", 18", 21" and 24" deep cabinets.
- Optional slides for drawer boxes 27" and 30" deep, utilize Blum MOVENTO 769 heavy duty slides with soft close.
- Full extension zinc coated steel.
- Cabinet sides have pre-drilled holes to fasten drawer slide with provided 5mm Euro-Screws for side mount application.
- 1/2" bottom reveal, undermount notch and hook hole required. Blum TANDEM sizing without slides also available.
- Blum drawer slides carry a limited lifetime warranty.
- Use Conestoga's online ordering system, Con-Nex or Conestoga order entry for pricing.

Vesta Loose Drawer Slide Kits	
Cabinet Depth	Slide Kit Number
12" and 13"	2100516
15" and 16"	2100515
18"	2100514
21"	2100513
24"	2100512
27"	2100511
30"	2100510

Cabinet Hinge Options

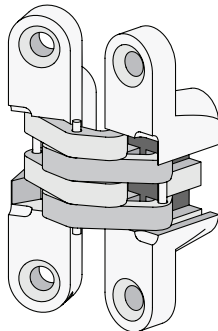

SOSS Hinge

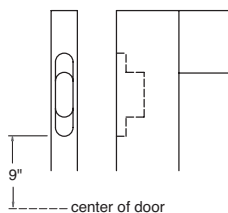

SOSS Hinge Option

- SOSS Hinge Model 204 Invisible Hinge provides 180 degree bi-fold hinge for corner pie cut cabinets.
- Available with WCP/CSWCP, WCPLS/CSWCLPLS, BCP/CSBCP and BCPLS cabinets.
- Available in Brass or Chrome finish; specify finish when ordering.
- Includes SOSS hinge boring; routs are placed 9" off center, measure from the vertical center of the door to the start of the rout.
- Not available on doors over 42" high or under 25-1/8" high.

Blum Full Access Cabinetry Hinge Program

Hinge and in-line mounting plate systems for standard, specialty and angled Full Access cabinets.

Soft close feature is integrated within the hinge cup itself unless otherwise noted.

Soft close function can be easily deactivated with a switch on individual hinges as needed based on the door size and weight.

Hinges packaged in pairs with mounting plates and instructions.

No screws required for hinge or mounting plate installation unless otherwise noted. Most hinges use cam style insert plugs.

In-line mounting plates utilize 32mm system holes and are concealed behind the hinge arm when installed for a clean interior appearance.

Hinge and mounting plate feature side to side, height and depth adjustment for fine tuning of door spacing.

Hinges require Pattern B with Insert Holes concealed hinge boring unless otherwise noted.

Blum hinges carry a limited lifetime warranty.

Lead-time is 5 days.

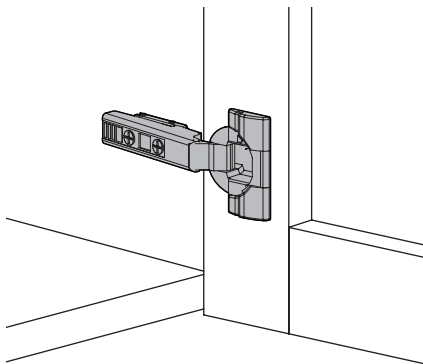

CLIP top BLUMOTION 110° hinge
EXPANDO in-line mounting plate

- **Blum INSERTA 110° Hinges**
- Hinge and in-line mounting plate system for standard Full Access Wall, Base and Tall cabinetry. Will not work in angle or specialty Full Access cabinetry.
- 110° opening angle.
- Part number: 2103574A.

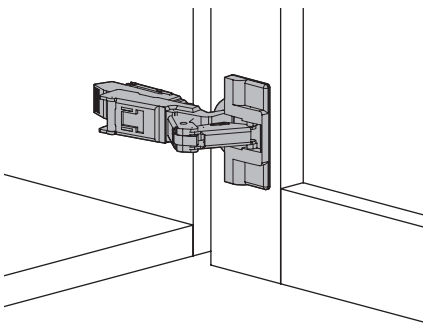

CLIP top 170° corner hinge
EXPANDO in-line mounting plate

Blum INSERTA 170° Corner Hinges

- Provides full access to corner cabinet interiors.
- 170° opening angle.
- Does not include soft close feature.
- INSERTA feature is not available on mounting plate. Kit includes installation screws.
- Part number: 2103575A.

Blum Full Access Cabinetry Hinge Program (continued)

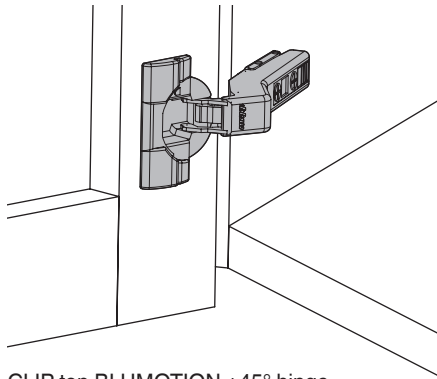

CLIP top BLUMOTION +45° hinge
EXPANDO in-line mounting plate

Blum INSERTA Positive +45° Angle Hinge

- Hinge and in-line mounting plate system for Full Access diagonal corner or any angle cabinet with a 45° front.
- 110° opening angle.
- Part number: 2103581A.

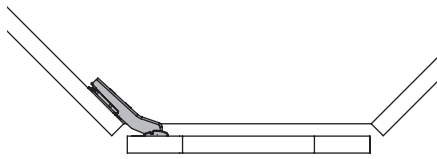

Top view

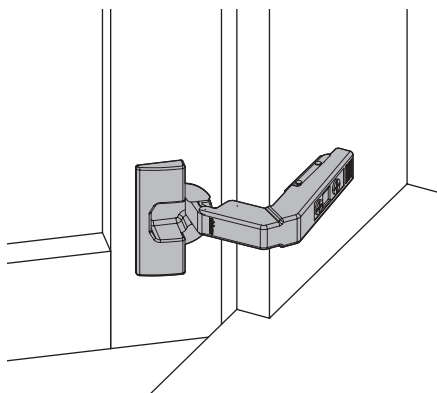

CLIP top 95° Overlay Blind Corner hinge
EXPANDO in-line mounting plate

Blum INSERTA 95° Overlay Blind Corner Hinge

- Hinge and in-line mounting plate system for Wall or Base Blind Corner cabinets.
- 95° opening angle.
- Part number: 2103582A.

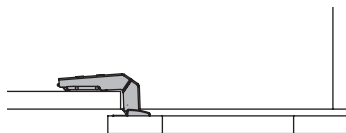

Top view

Blum Full Access Cabinetry Hinge Program (continued)

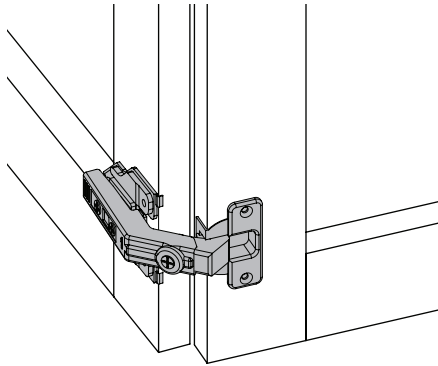

CLIP top 60° Bi-Fold hinge
Frame adaptor mounting plate

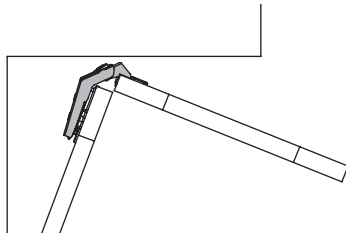

Top view

Blum 60° Bi-Fold Door Hinge

- Hinge and edge style mounting plate to join two doors in a bi-fold application.
- INSERTA installation feature is not available on hinge or mounting plates. Kit includes installation screws.
- Use with an 170° corner hinge on adjacent door (part number 2103575A).
- Does not include soft close feature.
- Requires Bi-Fold Hinge Bore without Insert Holes – See Section 7 in the Conestoga Custom Manual.
- 60° opening angle.
- Part number: 2103583A.

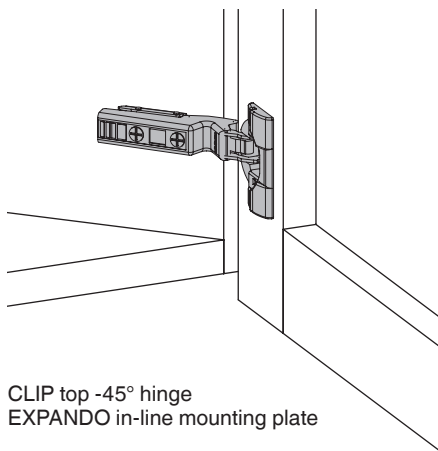

CLIP top -45° hinge
EXPANDO in-line mounting plate

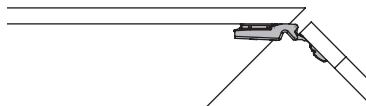

Top view

Blum INSERTA Negative -45° Hinge

- Hinge and in-line mounting plate system for Full Access angle cabinets or cabinet hinging on the opposite side of a 45°.
- 110° opening angle.
- Part number: 2103584A.

Blum Full Access Cabinetry Hinge Program (continued)

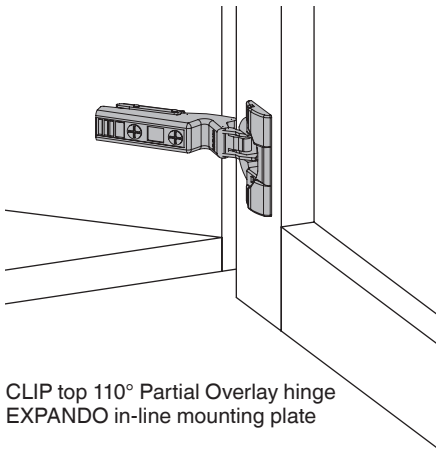

CLIP top 110° Partial Overlay hinge
EXPANDO in-line mounting plate

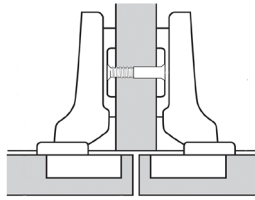

Top view

Blum INSERTA 110° Partial Overlay Hinge

- Hinge and in-line mounting plate system for Full Access applications where there is a center partition.
- 110° opening angle.
- Part number: 2103675A.